

FORD THOMPSON SLIPPER

Ford & Mercury (Exc. 460" & 400")

Torino, Elite

Montego, Cougar

Maverick, Comet

Granada, Monarch

Mustang, Pinto, Bobcat

DESCRIPTION

The Thompson Slipper pump is belt driven with an integral fluid reservoir. Spring loaded slippers within cam and rotor create pumping action. A flow control valve and relief valve maintain pumping volume and maximum operating pressure. An identification tag on back of pump indicates on top line the pump model. Use model code when requesting service parts as different internal components are used between pump models.

LUBRICATION, TROUBLE SHOOTING & TESTING

See Power Steering General Servicing in this section.

REMOVAL & INSTALLATION

POWER STEERING PUMP

Drain reservoir fluid by disconnecting fluid return line at reservoir. Disconnect pressure hose at pump and remove bolts from front of pump and nut at rear of pump (V8 models only) that secure pump to mounting bracket. Remove belt from pulley and pump from brackets. To install, reverse removal procedure. Adjust belt tension, refill and bleed pump, see Power Steering General Servicing in this section for correct procedures.

POWER STEERING PUMP PULLEY

Drain as much fluid as possible from pump through filler pipe. Install a 3/8 - 16 inch capscrew in end of pump shaft to prevent damage to shaft end by tool screw. Install a suitable pulley remover (T69L-10300-A) on pulley hub and remove pulley. **CAUTION** - Pulley must be removed with-out in and out pressure on shaft to prevent damage to internal thrust areas. To install, use a suitable tool to press pulley onto hub.

ROTOR SHAFT SEAL

Remove pulley and install pump assembly in a suitable holding fixture, pulley end of shaft up. Clean any rust or dirt from shaft. To prevent scoring of shaft, wrap .005 shim stock (free of burrs) around rotor shaft and push it into ID of the seal until it is against bushing. Using a sharp tool, carefully pierce the metal seal body face and pry old seal out. **CAUTION** - Do not damage bushing, housing or rotor shaft. Remove shim stock. Position new seal on end of Seal Protector, Tool T68P-3B592-B, position tool and seal on shaft. Use seal installer tool, T68P-3B592-A and a soft hammer to tap lightly against seal until it is completely installed flush with end of seal bore.

OVERHAUL

POWER STEERING PUMP

Disassembly - Remove outlet fitting and invert pump. Remove pump reservoir and seal by tapping with a plastic hammer. Turn pump over and remove housing assembly. Remove and replace housing cover "O" ring, oil screen (if equipped) and pressure springs if damaged. Discard pump cover gasket. Remove retainer end plate and upper pressure plate (with some units, plates are integral). Remove loose fitting dowel pin, do not bend fixed dowel pin in housing. Remove rotor assembly being careful to prevent springs and slippers from falling out. **NOTE** - Do not disassemble further unless lower pressure plate, housing plate, rotor shaft and/or

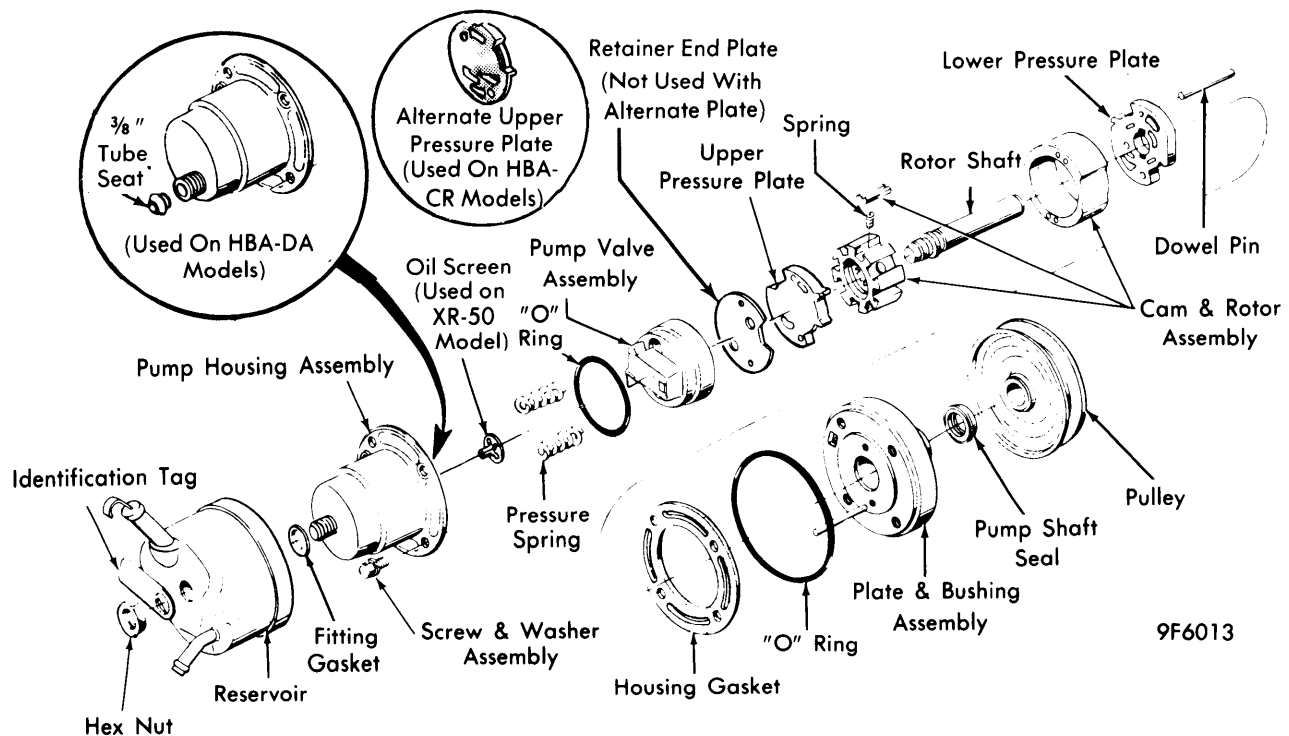

9F6013

THOMPSON SLIPPER POWER STEERING PUMP

Power Steering Pumps

FORD THOMPSON SLIPPER (Cont.)

seal is to be replaced. Invert pump and using a suitable tool (T69-10300-A), remove pulley. Clean pulley end of rotor shaft and remove rotor shaft and lower pressure plate.

Reassembly - 1) Position pump assembly in a suitable holding fixture, pulley side facing down. Insert lower pressure plate on anchor pin with wide chamfered slots at center hole facing up. Lubricate then insert rotor shaft into lower pressure plate and housing plate. If rotor assembly was disassembled, hold cam insert with notch on O.D. of cam at top, and arrow on O.D. of cam pointing downward.

2) Insert rotor in cam with the double step in the ID of the rotor facing upward. With rotor extended upward approximately one half way out of cam, insert a spring into a rotor spring pocket working in the rotor cavity directly beneath cam notch. Use one of the slippers to compress the spring and install the slipper with the groove in the slipper facing upward (toward cam notch). Flats on side of slipper should be on the left.

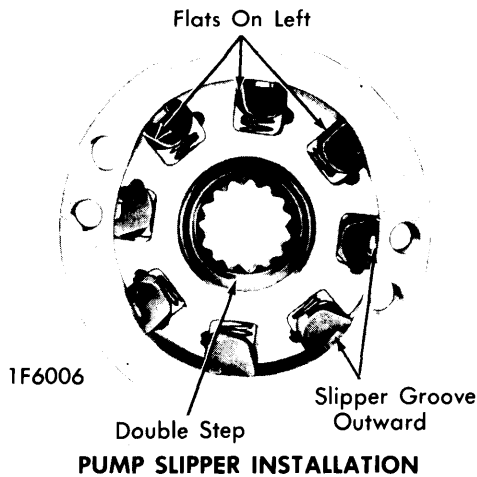

3) Hold cam stationary and turn rotor either right or left, one space at a time. Repeat until all cavities have been filled. **CAUTION** - Be careful when turning rotor that springs and slippers already inserted do not fall out. Install cam and rotor assembly onto pump housing plate with fixed dowel passing through the first hole to the left of the cam notch when the arrow on the cam OD is pointing toward the lower pressure plate. If cam and rotor will not seat, turn rotor shaft slightly until spline teeth mesh, allowing cam and rotor to drop down into position.

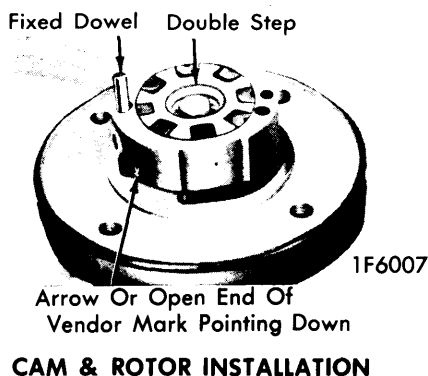

4) Insert loose fitting dowel through cam insert and lower plate into hole in housing plate assembly. When loose dowel is properly installed, heights of two dowels will be equal. Lubricate rotor, springs, slippers and cam insert with power steering fluid. Place upper pressure plate with face having tapered notch down against cam insert. Fixed dowel should pass through round dowel hole and loose dowel through elongated hole. Install retainer end plate so slot on endplate OD matches corresponding notches of upper pressure plate and cam.

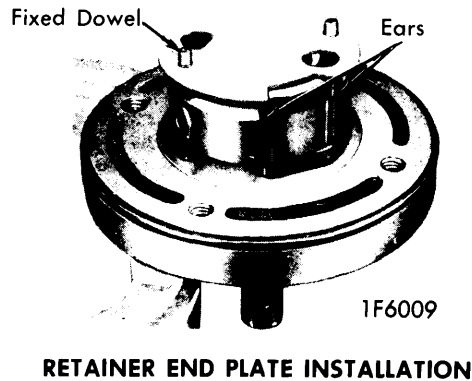
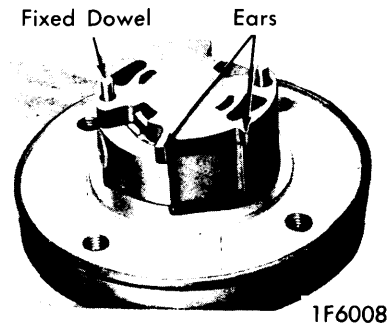

5) Install pump valve assembly "O" ring seal into pump valve assembly. Place assembly on top of retainer end plate with the large exhaust slot on the pump valve in line with the OD notches of the previously assembled parts. Stack of parts must be fully seated. If valve is installed correctly, relief valve stem will be in line with lube return hole in pump housing plate. Install oil screen assembly, if equipped.

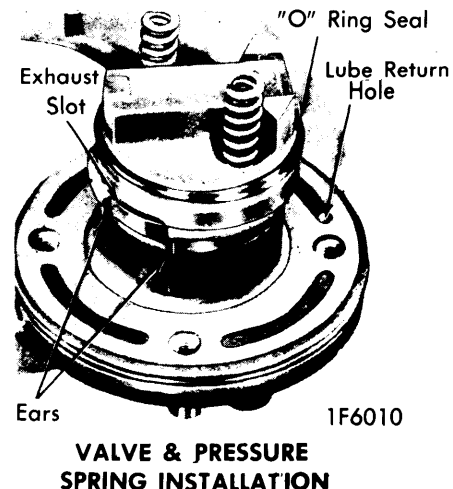

FORD THOMPSON SLIPPER (Cont.)

6) Install gasket on pump housing plate. Insert pressure plate springs into the pockets in the pump valve assembly. Use vaseline as an aid to hold springs in position. Using a suitable tool (T69P-3B586-A) plug the intake hole in the housing. Lubricate inside of housing and housing cover seal. Fabricate two studs (3/8-16x1.55) to be used as positioning guides. Install one in housing plate bolt hole closest to drain hole and one in bolt hole diametrically opposite.

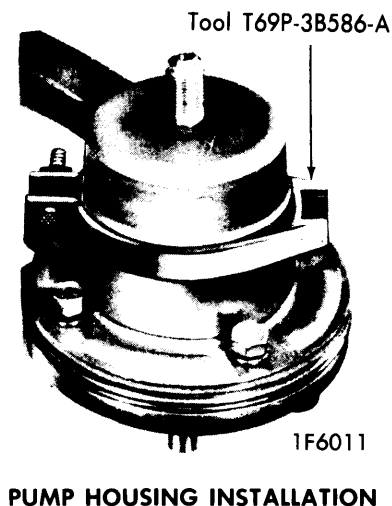

7) Align small diameter lube hole in housing rim with lube hole in housing plate. Install housing, applying even

downward pressure. *NOTE — Pressure plate springs must not be jarred and moved out of position.* Remove guide studs. Install housing retaining bolts finger tight. Torque bolts evenly to 28-32 ft. lbs. Install a 3/8-16 hex head screw finger tight into end of rotor shaft. Using an inch pound torque wrench, check rotational drag of pump shaft, drag torque should not exceed 15 INCH lbs. If drag torque exceeds 15 INCH lbs., loosen housing retaining bolts slightly, rotate rotor shaft and retor-que bolts evenly. Repeat this procedure until drag torque is under limit.

8) Shake pump assembly back and forth. If it rattles, pressure plate springs have fallen out of their seats and must be reinstalled. Install reservoir "O" ring on housing plate. Install reservoir, aligning notch in reservoir flange with notch in OD of pump housing plate and bushing assembly. Install identification tag and install outlet valve fitting nut.

TIGHTENING SPECIFICATIONS

Application	Ft. Lbs.
Pressure Hose-to-Pump Nut	28-34
Pump-to-Bracket (Front Bolt)	30-45
Pump-to-Bracket (Rear Nut)	20-30
Pressure Hose Clamp	12-24 INCH lbs.
Belt Adjustment Bolts	30-40
Housing-to-Plate Assembly	38-47
Reservoir-to-Housing	43-47