

AMERICAN MOTORS ADJUST-O-TILT

GENERAL INFORMATION

Adjust-O-Tilt steering column mechanism and components may be repaired or replaced without removing column from vehicle. If disassembly is to be extensive, or repairs are necessary to lower end of column, assembly should be removed and mounted in shop vise using fixture tool J-23074 or equivalent.

CAUTION — Components and fasteners used in steering column design are important in that they can affect vehicle safety and the performance of vital systems if not serviced properly. All replacement parts must be of same part number or equivalent quality. **DO NOT** use a part of lesser quality or substitute design. Torque all fasteners as specified during reassembly.

REMOVAL & INSTALLATION

Removal and installation procedures for Adjust-O-Tilt steering column is the same procedure used to remove and install Collapsible Steering Columns. See *American Motors Collapsible Steering Column* in this section.

DISASSEMBLY & REASSEMBLY

COLUMN UPPER END

1) Remove steering wheel and horn button. Remove shift lever retaining pin and lever (if column shift). Loosen cover screws and remove cover. Using suitable lock plate compressor tool (J-23653), depress lock plate and remove snap ring. **CAUTION** — Lock plate is under strong spring force, do not try to remove snap ring without spring compressor.

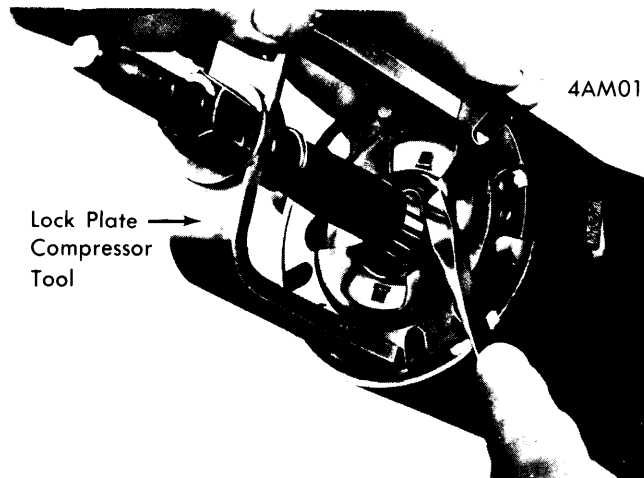

REMOVING LOCK PLATE SNAP RING

2) Loosen lock plate compressor nut and remove the tool, lock plate, directional signal cancelling cam, upper bearing preload spring, bearing race seat and bearing race.

3) Place signal switch in right turn position and remove handle. Depress hazard warning light switch and remove button by turning it counterclockwise.

4) Remove signal wire harness connector block from mounting bracket on lower right side of column. If equipped with Cruise Command, mark position of wires for correct assembly, then remove signal switch and wire harness from column.

5) Use a small wire hook to remove buzzer switch and clip as an assembly. Place lock in "RUN" position. Hook wire into buzzer switch contacts and pull out and up to remove contacts

and buzzer as an assembly. **CAUTION** — Do not attempt to remove switch separately as contacts may fall down column assembly.

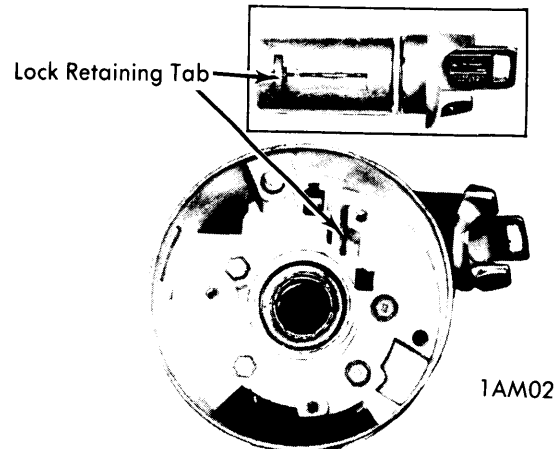

LOCK CYLINDER REMOVAL

6) Place key in "LOCK" position and, with a small screwdriver, depress lock cylinder retaining tab to remove cylinder. With Hornet and Gremlin models, remove shift quadrant. Quadrant is retained by a spring clip located behind quadrant indicator housing, remove clip with needle nose pliers. Remove shift quadrant mounting bracket and light socket (if equipped). Disconnect shift quadrant cable under steering column. Unscrew tilt release handle.

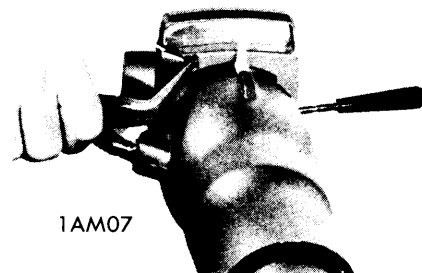

SHIFT QUADRANT RETAINER CLIP REMOVAL

7) Remove upper cover from column, then remove the lock sector tension spring. The spring must be unhooked from the lock bolt. Remove the Tru-arc snap ring from lock sector shaft and remove the sector, shaft and lock pin.

4AM03

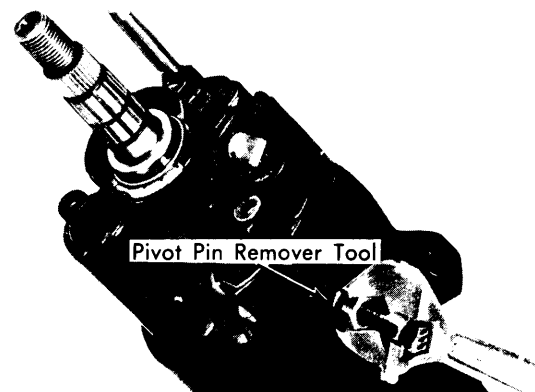

REMOVING PIVOT PINS

AMERICAN MOTORS ADJUST-O-TILT (Cont.)

8) Use release handle to place upper housing in full UP position. Insert screwdriver into slot in tilt spring retainer. Depress the retainer approximately 3/16" and rotate 1/8 turn counterclockwise to remove retainer and spring. **CAUTION** – Spring is under high compression.

9) With upper housing in straight position, remove two pivot pins using tool J-21854-1 or equivalent. Lift tilt handle to disengage lock shoes and to remove bearing housing assembly.

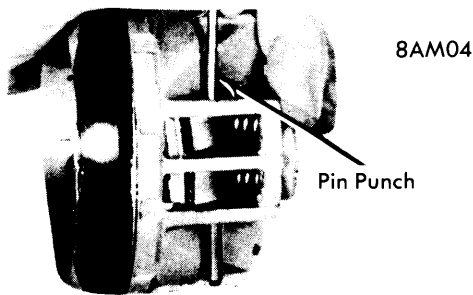

LOCK SHOE PIN REMOVAL

10) If lock shoes, release lever or springs are to be serviced, remove release lever pin and lock shoe pin. Hold lock shoe springs in compression to relieve the load on pins. Remove steering shaft from top of column. The flexible joint is disassembled by folding the shaft 90°.

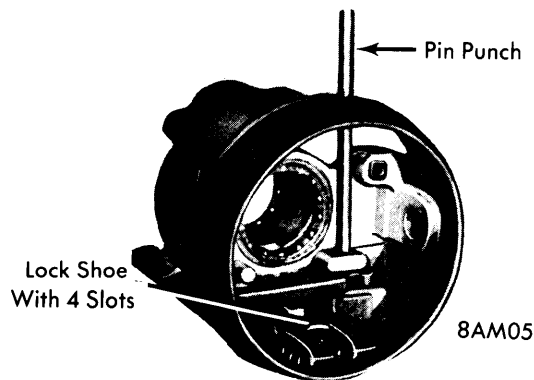

RELEASE LEVER PIN REMOVAL

11) Remove ignition switch, lock rack and rod, lower bearing retainer snap ring, retainer and bearing. Remove shift tube retainer ring and thrust washer. Use tool J-23072 to remove shift tube.

12) Take out retainer plate by rotating shift bowl clockwise and sliding plate out of jacket notches. Tip plate down toward shift bowl hub at 12 o'clock position and remove bottom side of plate first. Remove wave washer and shift bowl from column.

13) Apply thin coat of lithium grease (or equivalent) to all friction surfaces. Reassemble all components in reverse order of removal procedure.

NOTE – For torque specifications, see American Motors Collapsible Steering Column in this section.

COLUMN LOWER END

1) Remove steering column from vehicle. If lower section only is to be serviced, remove upper steering shaft snap ring, lock plate, turn signal cancelling cam, upper bearing preload spring, and thrust washer as previously detailed. Further disassembly of upper section is not necessary. Remove steering shaft pulling out from lower end of column.

2) On floor shift vehicles, remove lower bearing retainer ring and bearing. **NOTE** – Floor shift vehicles do not use plastic thrust washer or spring. On automatic transmission column shift vehicles, remove lower bearing retainer ring, bearing, preload spring and nylon washer.

3) On manual column shift models, remove back-up light switch, then lower bearing retainer ring and bearing. Remove 1st-Reverse shift lever and spacer (if equipped). Remove shift tube bearing retaining screws and remove shift tube. **NOTE** – If nylon shift tube bearing was not removed during upper section disassembly, remove at this time. To reassemble column, apply multi-purpose grease to all friction-bearing surfaces before assembly. Reverse removal procedures for reassembly.

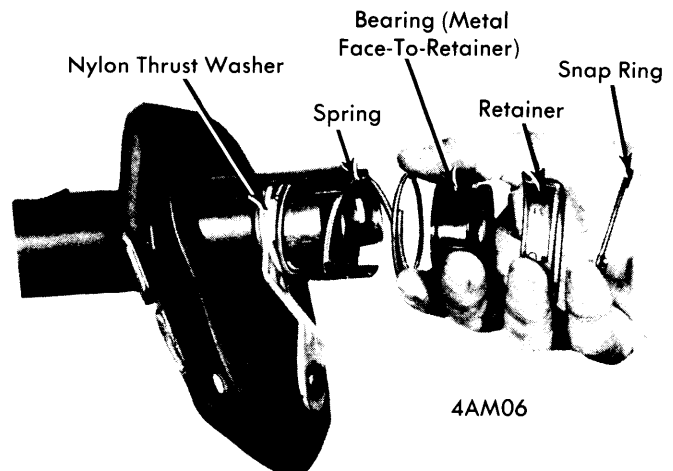

LOWER BEARING ASSEMBLY

Movable Steering Columns

AMERICAN MOTORS ADJUST-O-TILT (Cont.)

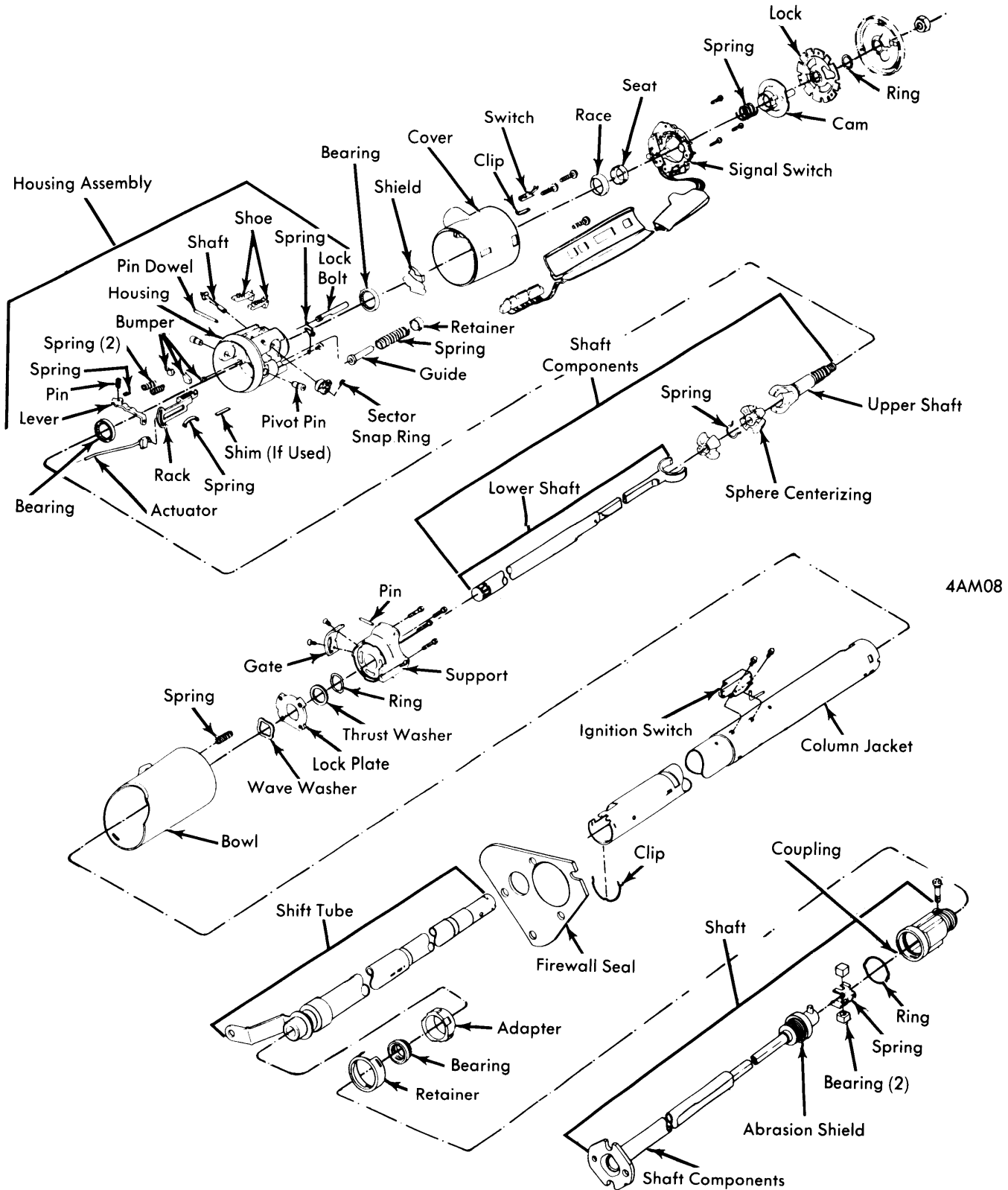

AMERICAN MOTORS ADJUST-O-TILT COLUMN ASSEMBLY