

# Rear Suspension

## BUICK, CADILLAC, CHEVROLET, OLDSMOBILE & PONTIAC

### General Motors

### ADJUSTMENT

**NOTE** — The following procedures apply to all General Motors vehicles with coil spring rear suspension except Astre, Chevette, Monza, Skyhawk, Starfire, Sunbird and Vega.

#### RIDING HEIGHT

See Riding Height Adjustments and Specifications in WHEEL ALIGNMENT Section.

#### REAR WHEEL BEARINGS

See Wheel Bearing Adjustment in WHEEL ALIGNMENT Section.

### DESCRIPTION

Rear suspension is of the link-type with coil springs. System uses four control arms that attach the rear axle assembly to the frame. A bracket on the axle supports coil springs. Top of coil spring is positioned under frame rail. Upper arms are attached to top of differential and extend forward to frame. Two shock absorbers are attached to frame and brackets on axle housing.

### REMOVAL & INSTALLATION

#### COIL SPRING

**Removal** — Raise and support vehicle at rear axle and frame. Disconnect shock absorbers at lower mounting. If equipped with Automatic Level Control, disconnect link at

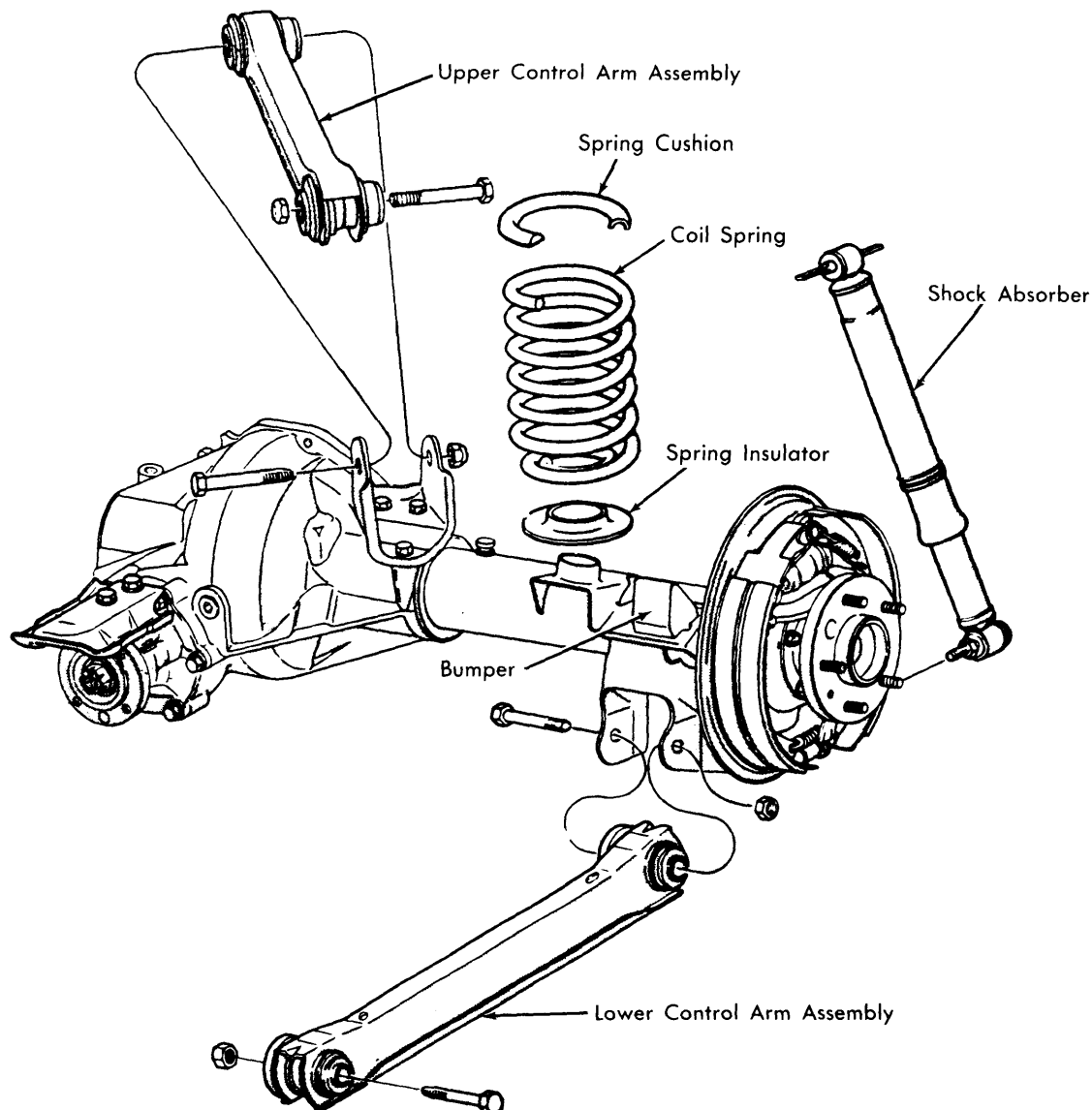

REAR COIL SPRING SUSPENSION

3F6010

## BUICK, CADILLAC, CHEVROLET, OLDSMOBILE & PONTIAC (Cont.)

overtravel lever and set lever in center position. **NOTE** — On Oldsmobile models, use suitable spring compressor to compress spring, then lower hoist and remove spring. Disconnect upper control arms from differential on all models except Bonneville, Catalina and Grand Ville. Disconnect brake line junction block at differential, then disconnect and plug brake lines from block. On Cadillac, unbolt and support propeller shaft rear flange. Lower axle slowly and remove springs. **CAUTION** — Do not allow axle to strain brake hoses.

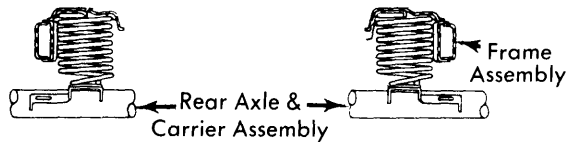

4CA02

### COIL SPRING POSITION (TYPICAL) (CADILLAC SHOWN)

**Installation** — Center spring in seat and rotate so that reference end points in direction shown in chart. To continue installation, reverse removal procedure.

Application	Spring Reference End	Direction
Buick	Top	Right
Cadillac	Top	Left
Chevrolet	Top	Right
Oldsmobile	Top	Right
Pontiac	Bottom	Left

### UPPER CONTROL ARM

**CAUTION** — Remove and replace one control arm at a time to prevent rear axle from rolling or slipping.

**Removal** — Raise vehicle on hoist and support rear axle. If equipped with Automatic Level Control, disconnect link at overtravel lever and set lever in center position. On Eldorado, remove shock absorber from lower mounting and position out of way. Unbolt control arm from upper and lower pivot bolt mountings and remove arm from vehicle.

**Installation** — Reverse removal procedures and tighten pivot bolts with vehicle on ground and at curb height.

### LOWER CONTROL ARM

**CAUTION** — Remove and replace one control arm at a time to prevent rear axle from rolling or slipping.

**Removal** — Raise and support rear of vehicle. Support axle housing to relieve tension on control arm bolts. Remove lower control arm pivot bolt (below axle housing). Disconnect control arm from frame crossmember and remove assembly.

**NOTE** — If vehicle is equipped with stabilizer bar it will be necessary to remove bar before unbolting arm.

**Installation** — Reverse removal procedures and tighten pivot bolts with vehicle on ground and at curb height.

### TIGHTENING SPECIFICATIONS

Application	CONTROL ARMS	
	Bolt	Nut
	Ft. Lbs.	
<b>Control Arms-to-Frame</b>		
Century & Regal	90	80
Buick (All Others)	95	85
Eldorado	145	110
Cadillac (All Others)	95	75
<b>Pontiac</b>		
Exc. Catalina & Bonneville	90	80
Catalina & Bonneville	95	85
Cutlass	90	80
88 & 98		100
Toronado		115
Chevelle & Monte Carlo		80
Chevrolet (All Others)		115
<b>Control Arms-to-Axle</b>		
Century & Regal	90	80
<b>Buick (All Others)</b>		
Upper	85	75
Lower	135	100
<b>Eldorado</b>		
Upper	110	80
Lower	145	100
Cadillac (All Others)	95	75
<b>Pontiac (Exc. Catalina &amp; Bonneville)</b>		
Upper	85	75
Lower	95	80
<b>Pontiac Catalina &amp; Bonneville</b>		
Upper	85	75
Lower	140	100
Cutlass, 88 & 98		80
<b>Toronado</b>		
Upper		90
Lower		115
Chevrolet (All Models)		80

### TIGHTENING SPECIFICATIONS

Application	Ft. Lbs.
<b>Shock Absorber (Upper)</b>	
Chevrolet & Cadillac	12
Pontiac	12
Buick & Oldsmobile (Exc. Toronado)	20
Toronado	25
<b>Shock Absorber (Lower)</b>	
Cadillac	50
Toronado	75
Pontiac	65
All Others	65
<b>U-Joint Yoke-to-Companion Flange</b>	
Oldsmobile	75
Cadillac	70
<b>Stabilizer Bar-to-Lower Control Arm</b>	
Cutlass & Pontiac	50
Chevelle & Monte Carlo	55