

CADILLAC – EXC. ELDORADO & SEVILLE

Cadillac, Except Eldorado & Seville

DESCRIPTION

System is an independent spring type suspension, consisting of two upper and two lower control arm assemblies, coil springs, shock absorbers, front diagonal tie struts, a stabilizer bar, and two integral steering knuckles. Suspension is designed to produce an anti-dive reaction during braking.

ADJUSTMENT

CASTER & CAMBER

See *Caster and Camber Adjustments and Specifications in WHEEL ALIGNMENT Section.*

RIDING HEIGHT

See *Riding Height Adjustments and Specifications in WHEEL ALIGNMENT Section.*

FRONT WHEEL BEARINGS

See *Wheel Bearing Adjustment in WHEEL ALIGNMENT Section.*

BALL JOINT CHECKING

See *Ball Joint Checking in WHEEL ALIGNMENT Section.*

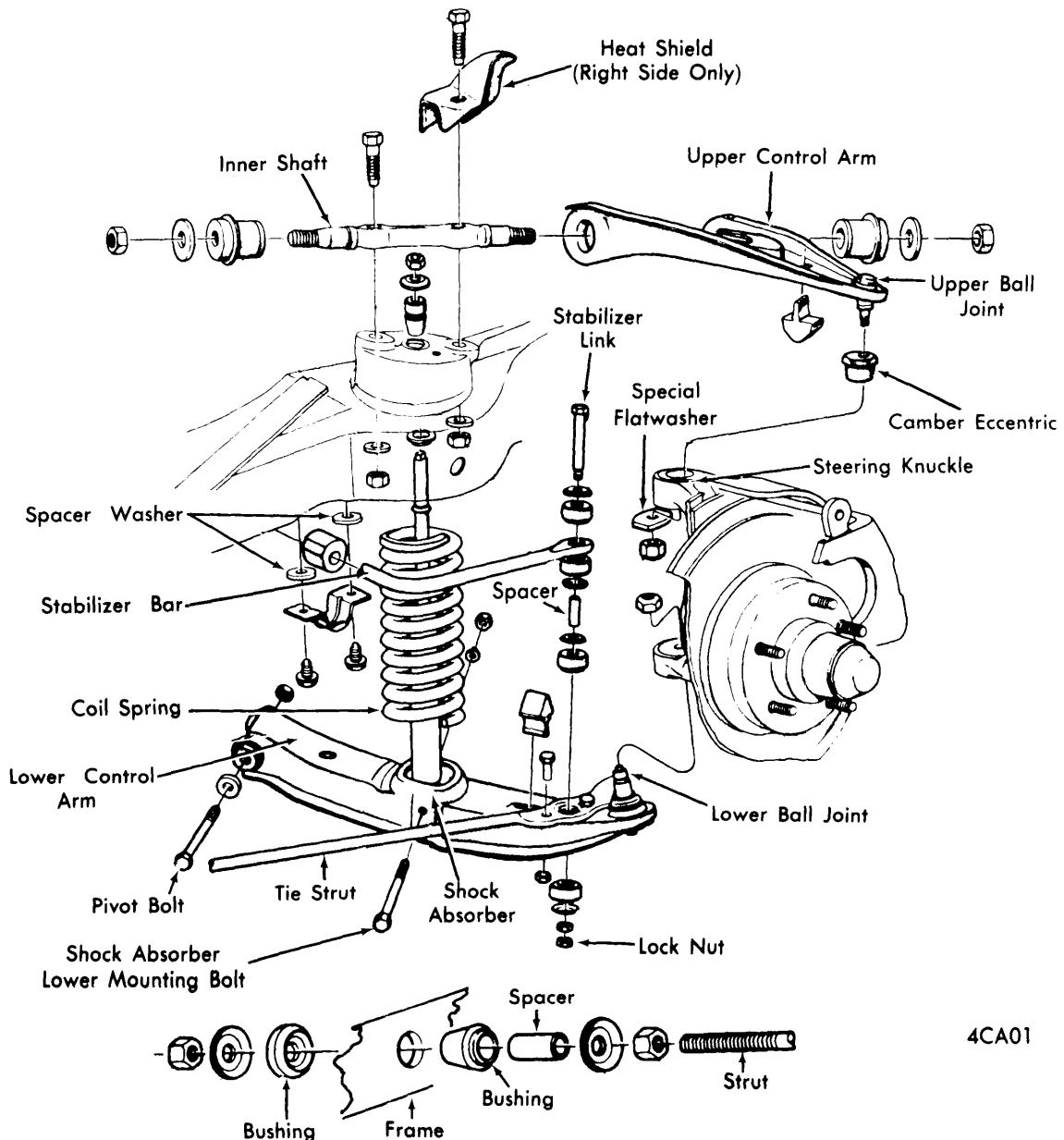

4CA01

FRONT SUSPENSION-CADILLAC (EXC. ELDORADO)

CADILLAC – EXC. ELDORADO & SEVILLE (Cont.)

REMOVAL & INSTALLATION

STABILIZER BAR

Removal – Remove nuts, retainer and grommet from bottom of each stabilizer link. Unbolt stabilizer mounting brackets from frame. Remove rubber bushings from bar, then remove grommets, retainers, spacers, and links from ends of stabilizer bar. Turn wheels to full stop and work stabilizer from vehicle.

Installation – Position stabilizer and install rubber bushings and mounting brackets. Install grommets, retainers, and nuts exactly as shown in suspension illustration. *NOTE* – Grommets and retainers are larger than those used on previous models, or on present shock absorbers. Ensure replacement parts are of correct size.

TIE STRUT & BUSHINGS

Removal – *NOTE* – If only bushing is being replaced, do not disturb strut rear locknut in order to avoid readjusting caster and camber. Raise car and disconnect stabilizer link from lower control arm on side from which strut is being removed. Remove tie strut and bushings.

Installation – If rear locknut was removed, install a new 3/4" thick locknut (screw nut on approximately 3/4" from end of thread). Position rear bushing retainer on tie strut with concave side against nut. Insert metal spacer into conical-shaped bushing from small end; place this assembly on strut (small end toward front of vehicle). Hold tie strut in horizontal position and insert threaded end through frame strut rod support member. Position opposite end on lower suspension arm, with pointed end inward (attach bolts loosely). Slide front bushing onto end of strut and against support member, with concave side toward frame. Install front bushing retainer in similar manner. Start new 5/8" thick locknut on threaded end of strut. Connect stabilizer link to lower control arm (ensure attaching parts are correctly positioned). Lower vehicle, position front bushing on metal spacer, and tighten all lock nuts. If rear lock nut was disturbed during tie strut removal or installation, adjust caster and camber.

UPPER BALL JOINT SEAL REPLACEMENT (ON CAR)

Removal – Raise and support car under lower control arms, then remove wheel and tire assembly. Loosen ball joint lock nut. Scribe mark camber eccentric and steering knuckle. Strike steering knuckle in area of upper ball joint with a hammer until joint is free from steering knuckle. Remove nut and special washer from stud. Remove ball joint from steering knuckle and remove camber eccentric from joint stud using suitable puller (J-24319). *NOTE* – If camber eccentric is seized or frozen to joint stud, remove upper control arm assembly and remove camber eccentric as a bench operation. Remove and discard spring and seal.

Inspection – Check ball for looseness or binding. Ball joint should turn in its socket at 24-48 INCH lbs. If ball joint is damaged or worn, replace joint and arm as assembly.

Installation & Lubrication – Remove service plug and install new seal as follows: Apply a small amount of suitable lubricant (1050411) around hole in seal. Wipe groove in joint housing clean and install seal on joint stud. Ensure large groove diameter of seal engages recess around joint housing.

Momentarily pry large lip of seal away from housing and allow air to enter. Grasp small end of seal and extend toward threaded end of stud. Install new garter spring on small end of suitable installer tool (J-9148), lubricate inside diameter of installer, and install spring on seal (see illustration) ensuring spring secures lip of seal in recess. *NOTE* – If spring separates during installation, it is not necessarily broken. Join spring ends together and lock by twisting male end counterclockwise two to three turns. Lubricate joint until approximately two teaspoons of lubricant escapes under seat at screwdriver (used to allow air entry). Install service plug. Apply light grease coating to outside taper of camber eccentric. Install eccentric. Install joint stud and eccentric into steering knuckle, aligning scribe marks. Install attaching nuts and tighten. Check and adjust camber.

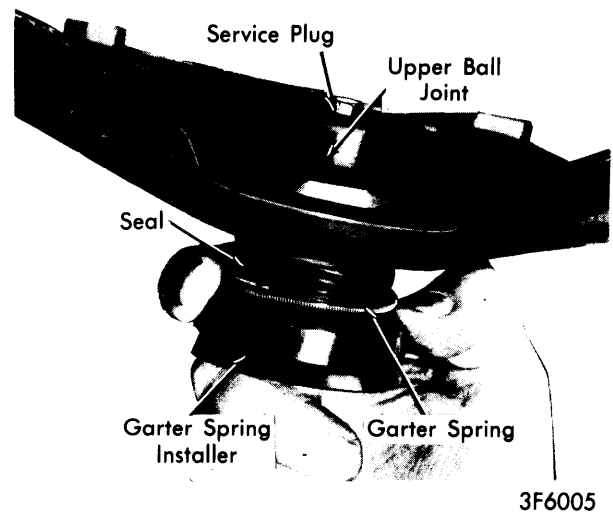

INSTALLING GARTER SPRING

LOWER BALL JOINT SEAL REPLACEMENT (ON CAR)

Removal – Raise and support car under lower control arms about 2" inboard of ball joints, then remove wheel and tire assembly. Remove ball joint lock nut and install a standard nut to within two threads of steering knuckle support, then raise car slightly off jack stands. Strike steering knuckle with hammer to break stud loose and lower car back on jack stands. Lift hub and caliper and remove steering knuckle from lower joint stud. Clean outer surface of seal and pry copper band from seal. Remove seal and discard seal and band. Remove service plug.

Installation – Install new seal on ball joint using suitable installer (J-22610) to position band on seal. Lubricate joint until approximately two teaspoons of lubricant escapes from joint. Install service plug. Guide ball joint into steering knuckle support, install standard nut and flat washer, and tighten until joint seats in support. Remove nut and washer, then install lock nut and tighten. *NOTE* – A large quantity of grease will purge from seal when it is seated in knuckle. Install wheel and tire assembly.

UPPER CONTROL ARM

NOTE – Upper ball joint is welded to control arm. Ball joint and control arm are serviced as a complete assembly only. Do not try to reweld ball joint to control arm.

CADILLAC – EXC. ELDORADO & SEVILLE (Cont.)

Removal – Raise and support front of vehicle at control arms. Remove wheel and tire assembly. Break loose upper ball joint, as previously described. Remove nuts, washers, and shaft mounting bolts at frame tower. Remove control arm and shaft assembly from vehicle. If right upper control arm is being removed, detach rear bushing heat shield. Remove nut and washer from each end of shaft. Camber eccentric may be removed, if necessary, by using a suitable puller (J-24319).

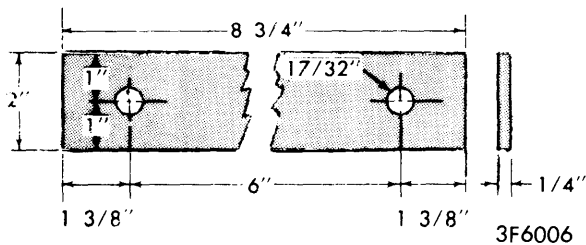

BUSHING REMOVAL SPACER TOOL

Bushing Removal – Make two spacers from cold, rolled steel (see illustration). Remove control arm and install spacers on shaft between arm ends; secure with bolts and nuts. Apply liberal amount of penetrating oil between bushing sleeve and arm. Position suitable support (J-8999-2) on anvil of arbor press and place one end of arm on support, with outer end of bushing resting in support. *NOTE* – It will be necessary to drill 1/4" hole in center of support base, to prevent bushing from bottoming before it is removed. Insert spacers (see illustration) and drive shaft downward until spacer plates touch extruded flanges of control arm, remove arm from press and repeat procedure on opposite side of control arm.

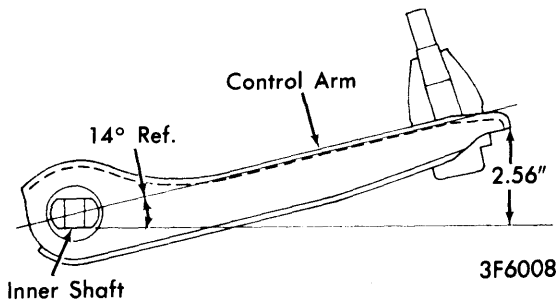

UPPER CONTROL ARM-TO-SHAFT ALIGNMENT

Bushing Installation – Insert inner shaft in control arm and place bushing over end of shaft and into hole in control arm. Place arm and bushing on suitable installer tool (J-8999-25) positioned on press. Rotate inner shaft until a 14° angle is achieved between shaft and control arm (see illustration). Position bushing on opposite end of shaft and position suitable installer tool. Check alignment of bushings, arm ends and shaft. Install suitable spacer (J-8999-1) around shaft between arm ends and press bushings onto shaft until both bushing flanges bottom on arms. *NOTE* – Bushing inner sleeves may not butt against shaft shoulder but will seat themselves when attaching nuts are tightened. Remove all installing tools and install flat washer and nut on each end of shaft (do not tighten).

Installation – Position control arm on frame tower (if right arm is being installed, position heat shield). Install and tighten mounting bolts. Install eccentric, if previously removed. Guide

eccentric and ball joint stud into steering knuckle, install standard nut and tighten until eccentric seats. Remove standard nut, then install lock nut and tighten. Install wheel and tire assembly and lower vehicle. Install flat washer and shaft attaching nut to end of control arm shaft. Check wheel alignment and adjust, if necessary.

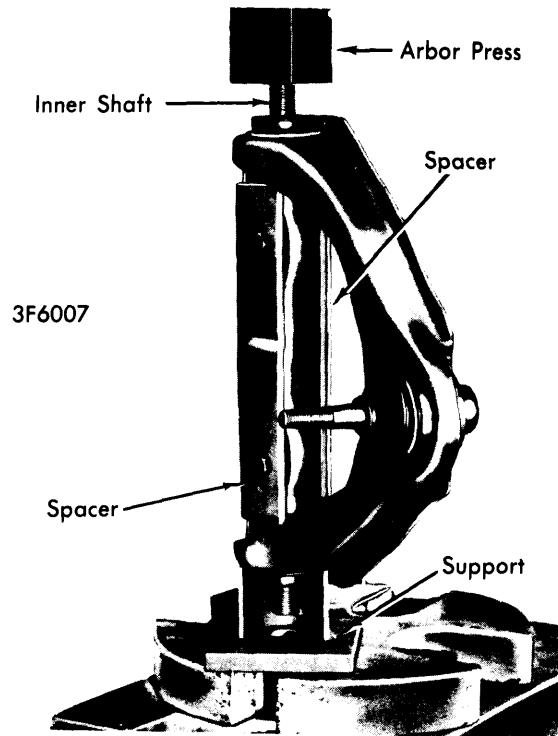

REMOVING UPPER ARM BUSHINGS

COIL SPRING

Removal – Raise and support vehicle under frame, remove shock absorber, and disconnect stabilizer bar and tie strut from lower control arm. Remove wheel and tire assembly. Position jack under outboard end of control to support arm. Remove control arm-to-frame pivot nuts. Break loose lower ball joint. *NOTE* – Raising opposite rear corner of vehicle will compress spring and facilitate ball joint removal. Slowly lower jack and remove coil spring.

Installation – Reverse removal procedure, noting the following: When replacing spring, position top of spring within the five depressions of frame tower. Bottom end, on left side, must be 1/2-1" in back of the front of lower control arm. On right side, spring must be 1/2-1" forward of the back of lower control arm.

LOWER CONTROL ARM

Removal & Installation – Remove coil spring and pivot bolts from control arm. Withdraw control arm from vehicle. To install, reverse removal procedure.

Bushing Removal – With control arm removed from vehicle, use stiff wire brush to clean small outer diameter end of bushing and portion of bushing between legs of control arm.

Front Suspension

CADILLAC – EXC. ELDORADO & SEVILLE (Cont.)

NOTE — This step prevents corrosion on bushing outer sleeve from damaging control arm upon bushing removal. Position suitable support (J-8999-2) on arbor press and insert large diameter end of bushing in support. Position suitable spacer (J-8999-20) around inner flange of control arm. Position suitable bushing remover (J-8999-10) on sleeve and press bushing from arm.

Bushing Installation — Reverse removal procedures.

STEERING KNUCKLE

Removal — Raise and support vehicle at side rails. Remove wheel and tire assembly. Detach and suspend brake caliper (do not disconnect brake hose). Pull hub and disc assembly from spindle. Unbolt and remove splash shield and seal. Place jack under lower control arm. Remove tie rod end from steering knuckle. Break upper and lower ball joints loose from knuckle. Lift knuckle from vehicle.

Installation — Reverse removal procedures, adjust front wheel bearings and check wheel alignment.

TIGHTENING SPECIFICATIONS

Application	Ft. Lbs.
Splash Shield-to-Knuckle.....	10
Lower Ball Joint-to-Knuckle.....	85
Upper Ball Joint-to-Knuckle.....	60
Stabilizer Bracket-to-Frame.....	35
Upper Control Arm-to-Frame Nuts.....	85
Control Arm Shaft Attaching Nuts.....	85
Lower Control Arm-to-Frame.....	85
Tie Rod Pivots-to-Knuckle.....	37
Tie Strut-to-Lower Arm.....	55
Tie Strut-to-Frame (At Front Bushing).....	50