

Front Suspension

BUICK, CADILLAC SEVILLE, CHEVROLET, OLDSMOBILE & PONTIAC

Buick (Exc. Skyhawk)
Cadillac Seville
Chevrolet (Exc. Corvette, Vega, Monza & Chevette)
Oldsmobile (Exc. Toronado & Starfire)
Pontiac (Exc. Astre & Sunbird)

DESCRIPTION

Independent front suspension is used on all models. Each wheel is attached to frame by means of a steering knuckle, upper and lower control arm, and ball joint assembly. Front wheels are held in proper relation by linkage which attaches to steering knuckle. Inner end of lower control arm is connected to frame with rubber pivot bushings and outer end is connected to steering knuckle by a ball joint. Inner end of upper control arm is attached to cross shaft, which bolts to frame. Outer end of upper arm is attached by a ball joint to steering knuckle. Side roll stability is maintained with stabilizer shaft, supported by brackets at each frame side rail (forward of springs). End of stabilizer shaft is connected to lower control arm. Coil springs are located between each frame side rail and lower control arm. Front shock absorbers are located within spring.

ADJUSTMENT

CASTER & CAMBER

See *Caster and Camber Adjustments and Specifications in WHEEL ALIGNMENT Section.*

RIDING HEIGHT

See *Riding Height Adjustments and Specifications in WHEEL ALIGNMENT Section.*

FRONT WHEEL BEARINGS

See *Wheel Bearing Adjustment in WHEEL ALIGNMENT Section.*

BALL JOINTS

See *Ball Joint Checking in WHEEL ALIGNMENT Section.*

REMOVAL & INSTALLATION

STABILIZER BAR

Removal — Support front end with stands at side rails. **NOTE** — It may be necessary to remove wheel and tire assembly to obtain suitable access. Disconnect both links from stabilizer shaft by removing each link nut and rotating shaft up from lower control arm. Remove screws holding stabilizer shaft brackets to frame. Remove brackets and rubber insulators from shaft. Remove stabilizer bar.

Installation — Reverse removal procedure and tighten nuts and bolts.

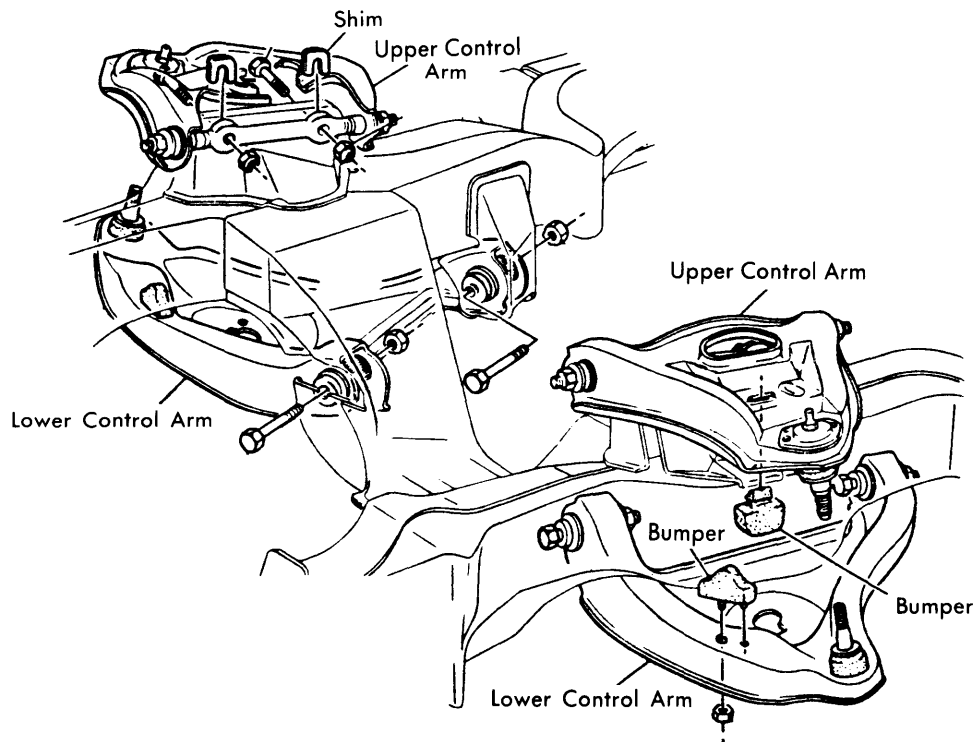

3F6003

FRONT SUSPENSION

BUICK, CADILLAC SEVILLE, CHEVROLET, OLDSMOBILE & PONTIAC (Cont.)

COIL SPRING

Removal (Exc. Oldsmobile) — Support vehicle at side rails, then remove wheel and tire assembly. Disconnect lower end of shock absorber and push up through spring. Disconnect front stabilizer rod link from lower control arm. Attach safety chain around lower control arm and coil spring. Position jack, with suitable removal tool (J-23028) attached, under lower control arm. Raise jack to remove tension on control arm pivot bolts. Remove pivot bolts and nuts (rear bolt first). Lower control arm slowly until spring is fully extended. Remove safety chain and spring. **NOTE** — Do not apply force on lower control arm and ball joint; proper maneuvering of spring will allow for easy removal.

Removal (Oldsmobile) — Support vehicle at side rails, then remove wheel and tire assembly. Disconnect front stabilizer rod link from lower control arm and remove shock absorber. Install suitable coil spring compression tools (J-7408) and compress spring until it is free in its seat. Remove two lower control arm pivot bolts and disengage lower control arm from frame (exc. Omega). Rotate arm with spring rearward and remove spring from arm. On Omega models, move control arm forward to remove spring.

Installation (All Models) — Reverse removal procedures and tighten nuts and bolts. Ensure spring is turned to proper mounting position as follows: On Nova, Apollo and Omega models top coil end must be $\frac{3}{8}$ " \pm $\frac{1}{8}$ " from stop. On all other models bottom end of coil spring must show in first hole and not cover second hole.

STEERING KNUCKLE AND/OR STEERING KNUCKLE ARM

Removal — Raise and support vehicle at front lower control arm (to keep spring compressed). If equipped with drum brakes, remove wheel and drum as assembly (it may be necessary to back off brake adjustment). With disc brakes, remove wheel and tire assembly, then remove hub dust cap. Detach and suspend brake caliper assembly. **NOTE** — Do not disconnect brake hose. Withdraw disc and hub assembly. On drum brakes, remove backing plate and brake assembly from steering knuckle, and move steering arm out of way. On disc brakes, remove splash shield and mounting bracket from steering knuckle, and move steering arm out of way. **NOTE** — Ensure brake hose is not strained. Remove tie rod end (if necessary). Pry upper and lower ball joint studs from steering knuckle. Remove knuckle from vehicle.

Installation — Reverse removal procedure while noting the following: Tighten all nuts and bolts. Adjust front wheel bearings.

UPPER CONTROL ARM

Removal — Support vehicle at front lower control arms (to keep spring compressed). Remove wheel and tire assembly. Pry upper ball joint stud from steering knuckle. Unbolt upper control arm. Remove shims, control arm, and shaft assembly.

Installation — Reverse removal procedure, tightening nuts and bolts. Check front end wheel alignment.

Bushing Service — With control arm removed from vehicle, remove nut and retainer from both ends of control arm shaft. **NOTE** — If end nuts are tack welded in place, bushings cannot be replaced. Complete upper control arm assembly must be replaced. Place control arm in an arbor press and position suitable tools as required. Press out and discard old bushings. Reverse procedure, for installation.

LOWER CONTROL ARM

Removal — Remove coil spring and stabilizer link. Pry lower ball joint stud from steering knuckle. Unbolt control arm from frame and remove control arm.

Installation — Reverse removal procedure, tightening nuts and bolts. **CAUTION** — Tighten control arm-to-frame attaching bolts with car off the hoist and at curb weight. Check front end wheel alignment.

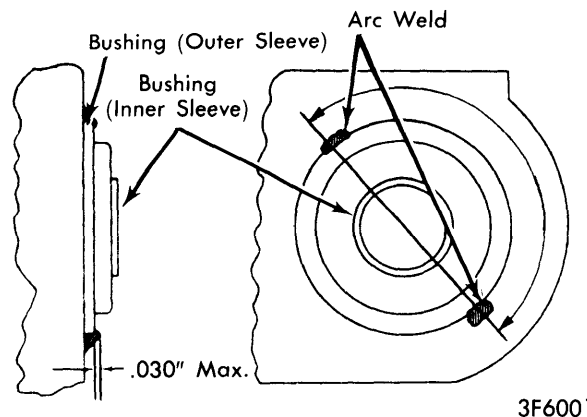

3F6001
LOWER CONTROL ARM BUSHING INSTALLATION (TACK WELD)

Bushing Service (Except Oldsmobile) — Raise vehicle and support at side rails. Remove lower shock absorber bolts and/or nuts and push shock up into coil spring. Remove front stabilizer rod link from lower control arm. Position jack, with suitable tool (J-23028) attached such that bushings seat in grooves of tool. Install a safety chain around control arm and coil spring. Remove control arm pivot bolts (rear bolt first). Slowly release jack and lower control arm until there is clearance to install bushing removal tools. **CAUTION** — Install suitable spacer (J-21474-12) to prevent distortion of lower control arm. After new bushings are installed, flare or tack weld as necessary (see illustrations). Reverse removal procedure to reinstall control arm and check front wheel alignment.

Bushing Service (Oldsmobile) — Remove control arm from vehicle and use suitable tools to press bushings from arm. After new bushings are installed, flare or tack weld as necessary (see illustrations). Reverse removal procedure to reinstall control arm and then check front wheel alignment.

UPPER BALL JOINT

Removal — Raise vehicle and support lower control arm. Remove wheel and tire assembly. Pry ball joint stud from steering knuckle. Chisel or drill rivets which retain ball joint. Remove ball joint.

Installation — Reverse removal procedure, using special nuts and bolts supplied in service kit. Tighten all nuts and bolts and adjust front wheel bearing.

Front Suspension

BUICK, CADILLAC SEVILLE, CHEVROLET, OLDSMOBILE & PONTIAC (Cont.)

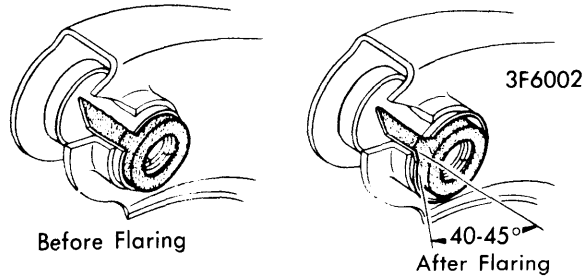
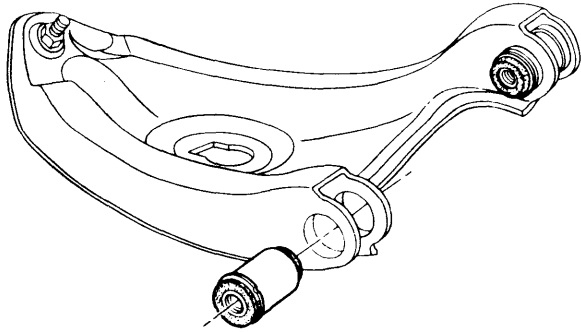

LOWER CONTROL ARM BUSHING INSTALLATION (FLARING)

LOWER BALL JOINT

Removal — Raise vehicle and support lower control arms under spring seats. This keeps spring compressed and allows removal tool to have proper clearance. Remove brake caliper assembly and suspend out of way. **NOTE** — Do not disconnect brake hose. Pry ball joint stud from control arm. Remove ball joint seal and retainer (pry off with screwdriver). Remove ball joint. **NOTE** — Nova lower ball joint is not internally preloaded, but firmly seated by weight of vehicle. When vehicle is supported by lower control arm (spring load removed from ball joint) some normal clearance looseness may be noticed; this does not necessarily indicate defective or worn ball joint.

Installation — Reverse removal procedures, tightening nuts and bolts.

TIGHTENING SPECIFICATIONS

Application	Ft. Lbs.
Upper Ball Joint Stud	
All (Exc. Omega).....	60
Omega	50
Lower Ball Joint Stud	
Buick & Chev.	90
Cadillac Seville	90
Oldsmobile (Exc. Omega)	90
Omega	80
Pontiac (Exc. Catalina & Bonneville).....	80
Catalina & Bonneville	90
Upper Control Arm-to-Frame	
Buick.....	70
Cadillac Seville	80
Chevrolet	75
Oldsmobile (Exc. Omega)	85
Omega	50
Pontiac	75
Lower Control Arm-to-Frame	
Buick (Exc. Apollo).....	①
Apollo	100
Cadillac Seville	95
Chevrolet & Olds. (Exc. Omega).....	100
Omega	80
Pontiac	①
Stabilizer Bar Bracket-to-Frame	
All (Exc. Seville, Omega & Cutlass).....	25
Cadillac Seville	27
Omega & Cutlass.....	30
Stabilizer Link Nut	
Buick (Exc. Apollo) & Cad. Seville	12
Apollo	18
All Others	15

① — Torque nut to 95 ft. lbs., or bolt to 130 lbs.