

## DELCO-MORAINE SINGLE PISTON DISC

**Buick**  
**Cadillac**  
**Chevrolet (Except Corvette)**  
**Oldsmobile**  
**Pontiac**

### DESCRIPTION

Caliper unit is constructed from single casting which contains one large piston bore in inboard section of casting. Piston is constructed of nickle-chrome plated steel. Caliper unit is mounted on support bracket attached to front suspension. **NOTE** — On some models, caliper is directly connected to steering knuckle. Brake rotor utilized is cast iron type using two machined braking surfaces (one on each side of rotor) separated by ventilation fins. Some models use an added groove in center of rotor braking surfaces to aid in reduction of brake noise. Shoe and lining assemblies are constructed of stamped steel shoes with riveted linings. Some models are equipped with spring steel wear sensors riveted to rear edge of inner brake shoe. When lining has worn to within .030" of rivet heads, sensor contacts rotor, causing very audible high frequency squeal.

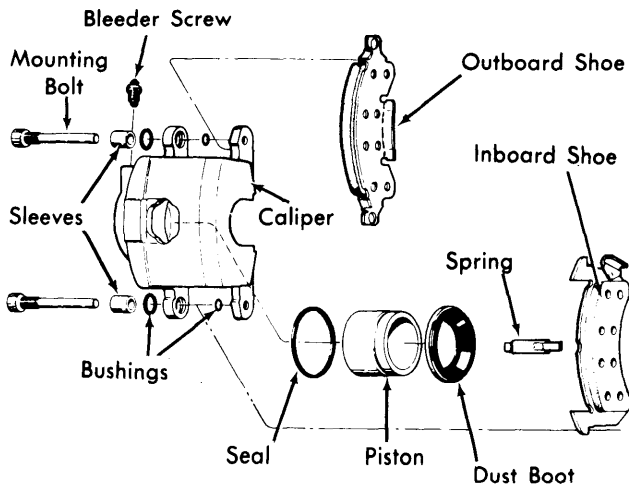

**CALIPER ASSEMBLY**

### ADJUSTMENT

Shoe wear is automatically compensated for by sliding caliper feature, therefore, no brake adjustment in service is required.

### SERVICING

#### BLEEDING

See *Hydraulic Brake Bleeding* in this section.

#### SHOE & LINING INSPECTION

Inspect linings every 6,000 miles or any time wheels are removed. Check both ends of inboard and outboard linings for wear. Replace all linings if any lining wears to following limits:

Buick .....	Within .020" of Rivets
Cadillac & Oldsmobile .....	Approx. Thickness of Shoe
Chevrolet.....	Within $\frac{1}{32}$ " of Shoe or Rivets
Pontiac .....	.125"

#### SHOE & LINING REPLACEMENT

**NOTE** — Relining should be done in complete sets only.

**Removal** — 1) Remove and discard two-thirds of brake fluid in master cylinder front reservoir. **CAUTION** — Do not remove brake line, or completely empty master cylinder, or it will be necessary to bleed system. Raise vehicle and remove front wheels. Position a "C" clamp on caliper (Except Pontiac), with solid side of clamp resting against inside of caliper, and screw end of clamp against outboard shoe. Tighten clamp until caliper moves away from vehicle far enough to push piston to bottom of its bore. This will allow shoes to back off from rotor surface.

2) Remove "C" clamp. On Pontiac, using a suitable lever, pry caliper outward as far as possible. This will push piston to bottom of bore. Unbolt caliper from support bracket or steering knuckle. **NOTE** — On Eldorado, remove cotter pin, loosen upper ball joint nut, and slip brake hose collar out of clip. Slack gained will permit removal of caliper without pulling hose. Lift caliper off rotor, remove shoes, then position caliper so that weight is taken off hose. Remove shoe support spring from cavity in piston. Using a suitable tool, remove sleeves from inboard ears of caliper, and rubber bushings from all caliper ears.

**Installation** — 1) Using silicone lubricant, coat and install new sleeves and rubber bushings in caliper ears. Attach shoe support spring to inboard shoe, then position shoe in caliper with wear indicator (if equipped) to rear of vehicle. **NOTE** — With wear indicator, there is a specific right side and left side inboard shoe. Position outboard shoe in caliper, engaging tab at bottom of shoe with caliper cutout, and shoe ears with caliper ears at top of shoe. Place caliper over rotor, aligning caliper ears with mounting holes.

2) Start bolts through inboard caliper ears and mounting bracket, making sure bolts pass under retaining ears of inboard shoe. Push bolts through to engage holes in outboard shoe and ears of caliper, then thread bolt into mounting bracket and tighten. Add brake fluid to fill master cylinder to within  $\frac{1}{8}$ " of top, then pump brake pedal to seat linings against rotor. Using suitable pliers, clinch upper ears of outboard shoe against caliper, making sure ears are flat against caliper with no clearance. On Eldorado models, place brake hose in clip and tighten upper ball joint nut. On all models, install wheels and lower vehicle to floor. **CAUTION** — Ensure solid brake pedal and full master cylinder before moving vehicle.

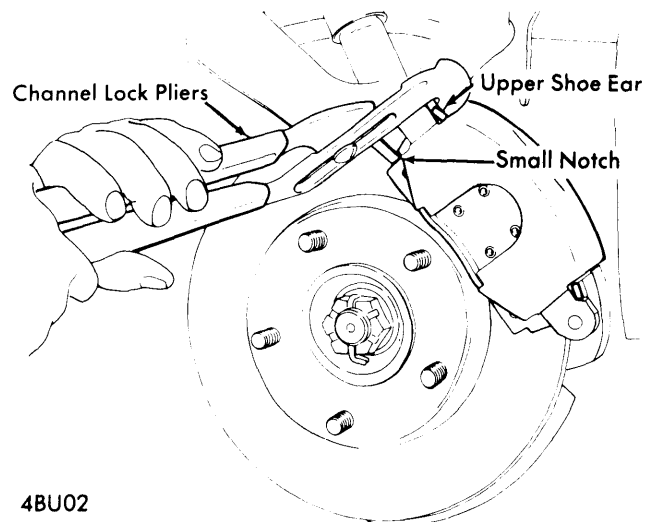

**CLINCHING OUTBOARD SHOE**

## DELCO-MORAINE SINGLE PISTON DISC (Cont.)

### ROTOR SERVICING

**Lateral Runout** — Adjust wheel bearings until all endplay is eliminated. Attach a dial indicator to front suspension so that pointer contacts face of rotor approximately one inch from rotor edge. Set gauge to zero, then turn rotor through one complete revolution noting gauge. See Rotor Specifications for maximum allowable runout.

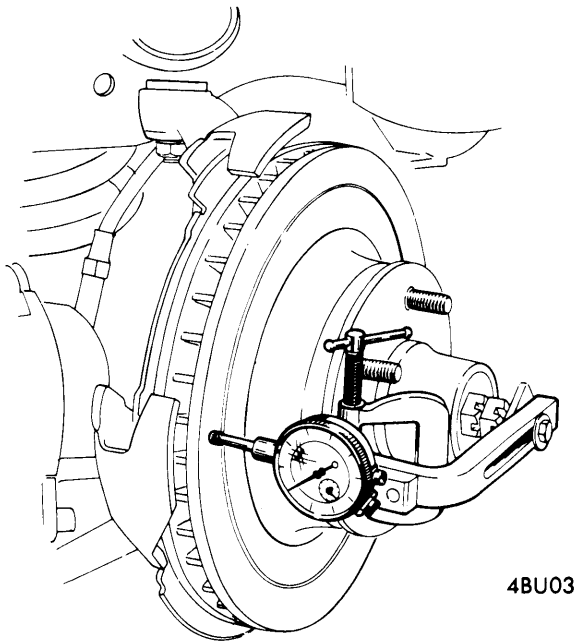

CHECKING LATERAL RUNOUT (TYPICAL)

**Parallelism** — Check thickness of rotor at four or more points around circumference of rotor. Make all measurements at same distance from edge of rotor. If thickness varies more than specified (see specifications), refinish or replace rotor as necessary.

### REMOVAL & INSTALLATION

#### BRAKE CALIPER

Removal of caliper for overhaul is same procedure as for lining replacement, except it is necessary to disconnect brake hose.

#### OVERHAUL

#### BRAKE CALIPER

**Disassembly** — Clean exterior of caliper with denatured alcohol and place on a clean work surface. Remove brake hose and discard copper gasket, then drain fluid from caliper. Using clean shop towels to pad interior of caliper, apply compressed air to caliper inlet and remove piston. **CAUTION** — Use only enough air pressure to ease piston out of bore. Using a screwdriver, pry boot out of caliper, then pry piston seal from caliper using a piece of wood or plastic. **CAUTION** — Do not use a metal tool to remove piston seal as bore may be damaged. Remove bleeder valve from caliper.

**Cleaning & Inspection** — 1) Boot, piston seal, rubber bushings, and sleeves must be replaced each time caliper is overhauled. Clean all other parts in denatured alcohol, then dry using dry filtered compressed air. **NOTE** — Using lubricated shop air will leave a film of mineral oil on metal parts, which may damage rubber parts upon contact at reassembly. Check mounting bolts for corrosion, breaks in plating, or other damage. **NOTE** — Do not attempt to clean bolts, replace them.

2) Check outside diameter of piston for scoring, nicks, corrosion, worn or damaged plating. If surface defects exist, replace piston. **CAUTION** — Do not attempt to refinish piston with abrasives. Check piston bore in caliper for scratches or other damage. Minor scratches or corrosion may be polished clean with crocus or emery cloth. Thoroughly clean bore after polishing. Replace caliper if corrosion is not easily cleaned.

**Reassembly** — Lubricate bore in caliper and new piston seal with clean brake fluid. Position seal in caliper bore groove. Lubricate piston with clean brake fluid, then assemble new boot into groove in piston, with fold facing open end of piston. Insert piston into caliper bore using care not to unseat seal. Do not force piston to bottom of bore. Position outer diameter of boot in caliper counterbore, then seat boot using suitable tool (J-22904). Check boot installation to make sure retaining ring molded into boot is not bent, and that boot is installed completely below caliper face. Install brake hose, using a new copper gasket. **NOTE** — After caliper has been overhauled and installed, it must be bled.

### TIGHTENING SPECIFICATIONS

Application	Ft. Lbs.
<b>Brake Hose-to-Caliper</b>	
Buick & Chevrolet .....	22
Cadillac .....	30 (Max.)
Oldsmobile	
Omega & Starfire .....	22
Cutlass, 88 & Ninety-Eight .....	25
Toronado .....	35
Pontiac .....	
<b>Caliper-to-Mounting Bracket</b>	
Buick, Chevrolet & Pontiac .....	35
Cadillac .....	30
Oldsmobile .....	40
<b>Wheel Attaching Bolts</b>	
Buick	
Century, Regal, Apollo & Skyhawk .....	70
All Others .....	90
Cadillac .....	100
Chevrolet .....	80
Oldsmobile	
Cutlass, Omega & Starfire .....	80
88 & Ninety-Eight .....	100
Toronado .....	135
Pontiac	
Bonneville, Catalina & Grand Ville .....	75
All Others .....	70

# Brake Systems

## DELCO-MORAINE SINGLE PISTON DISC (Cont.)

DISC BRAKE ROTOR SPECIFICATIONS						
Application	Disc Diameter	Lateral Runout	Parallelism	Original Thickness	Minimum Refinish Thickness	Discard Thickness
<b>Buick</b>						
Skyhawk	9.88"	.005"	.0005"	.500"	.455"	.440"
Apollo, Skylark, Century & Regal	11.00"	Ⓢ.004"	.0005"	1.040"	.980"	.965"
All Others	11.86"	.005"	.0005"	1.290"	1.230"	1.215"
<b>Cadillac</b>						
Eldorado	11.00"	.008"	.0005"	1.205"	.....	1.190"
All Others	11.74"	.005"	.0005"	1.285"	1.220"	1.215"
<b>Chevrolet</b>						
Vega & Monza 2+2 Chevelle, Nova & Camaro	9.88"	.005"	.0005"	.500"	.455"	.440"
All Others	11.00"	.005"	.0005"	1.035"	.980"	.965"
	11.86"	.005"	.0005"	1.280"	1.230"	1.215"
<b>Oldsmobile</b>						
Starfire	9.88"	.005"	.0005"	.500"	.455"	.440"
Toronado	10.88"	.002"	.0005"	1.245"	1.185"	1.170"
88 & Ninety-Eight	11.74"	.005"	.0005"	1.290"	1.230"	1.215"
All Others	10.88"	.004"	.0005"	1.040"	.980"	.965"
<b>Pontiac</b>						
Bonneville, Grand Ville & Catalina	11.88"	.004"	.0007"	1.285"	1.230"	1.215"
All Others	11.00"	.004"	.0007"	1.035"	.980"	.965"

Ⓢ — Apollo has lateral runout of .005".