

## BENDIX TANDEM DIAPHRAGM

American Motors  
 Buick  
 Chevrolet  
 Chrysler Corp.  
 Oldsmobile  
 Pontiac

### DESCRIPTION

Unit is a self-contained, vacuum-hydraulic power unit and is vacuum-suspended type. It uses engine intake manifold vacuum to take advantage of atmospheric pressure for power. Unit consists of three basic parts: Vacuum power chamber comprised of front and rear shell, center plate, tandem front and rear diaphragms (with plate assembly), hydraulic push rod and vacuum diaphragm, and diaphragm return spring; mechanically actuated control valve, integral with power diaphragms, consisting of single poppet with atmospheric and vacuum ports; tandem master cylinder.

### REMOVAL & INSTALLATION

#### AMERICAN MOTORS

**Removal** — Disconnect vacuum lines and hydraulic lines at master cylinder. From under instrument panel, disconnect push rod from brake pedal and remove nuts securing power unit to dash.

**Installation** — Reverse removal procedure and bleed brakes.

#### BUICK, CHEVROLET, OLDSMOBILE, & PONTIAC

**Removal** — Disconnect vacuum lines and hydraulic lines. Disconnect rod from brake pedal. Unbolt power unit and remove from vehicle.

**Installation** — Reverse removal procedure and bleed system.

#### CHRYSLER CORP.

**Removal** — Disconnect master cylinder from power unit. Disconnect vacuum line from check valve. From under dash, remove push rod from brake pedal and remove nuts securing power unit to dash.

**Installation** — Reverse removal procedure and bleed brakes.

### OVERHAUL

**NOTE** — American Motors and Chrysler Corp. do not recommend overhaul of this power brake unit.

**Disassembly** — 1) Scribe mark across master cylinder flange and power unit halves for reassembly. Remove master cylinder, then remove push rod and seal. Slide seal from rod. Remove vacuum check valve and grommet, if necessary. From rear housing air valve rod, remove dust boot and filter silencer. Extract air filter retainer, air filter, and silencer, using an awl or other suitable tool. Reinstall steel retainer to hub. Pour alcohol down valve operating rod (to aid removal), place end of rod in vise, and pry rod from unit (see illustration).

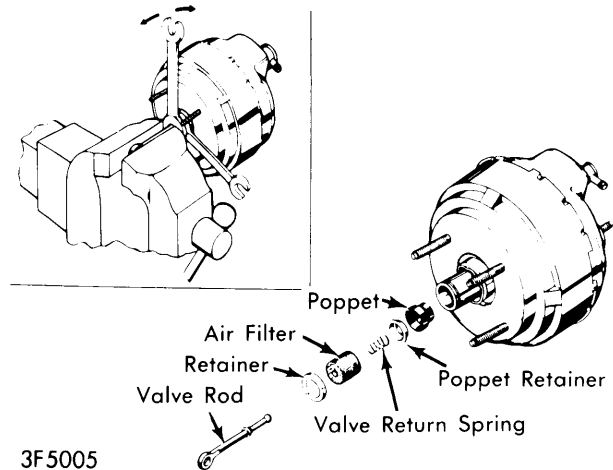

### VALVE ROD DISASSEMBLY & REMOVAL

2) Straighten four longest tabs on rear housing. Attach suitable separator tool (J-23456), apply slight downward pressure and turn front housing counterclockwise, release pressure on housing, then separate housings. Remove diaphragm assembly from rear housing. If necessary, use suitable tool and drive seal from rear housing. Wet rear diaphragm spring retainer with alcohol and remove diaphragm from rear plate (using fingers only).

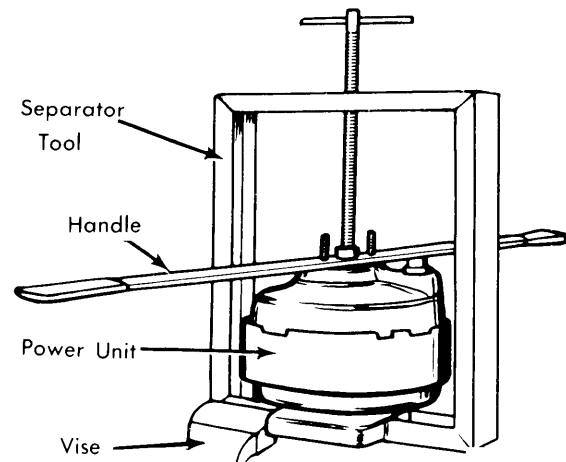

### SEPARATING FRONT & REAR HOUSINGS

3) Place 1 1/16" hex stock (2" long) in vise, or other suitable tool (J-22839), set diaphragm and plate assembly on tool, then twist rear plate counterclockwise until plates are loose. Remove assembly from tool and place on bench with front plate down. Lift rear plate from front plate hub. Remove valve plunger and spring. Remove "O" ring. Push out reaction disc. Slide center plate from front plate hub.

## BENDIX TANDEM DIAPHRAGM (Cont.)

**Cleaning & Inspection** – Clean all metal and rubber parts in alcohol. Remove rusted or corroded spots from metal areas with crocus or emery cloth. Dry all components with compressed air. Just before reassembly, rewash all metal components coming in contact with hydraulic fluid, in clean alcohol. Dry with compressed air. Use all parts included in repair kit and discard all old rubber parts.

**Reassembly – 1)** If rear bearing and seal were removed, install new parts, using suitable driver (J-22677). Install reaction disc to front plate hub, with small tip toward hole. Mount front plate on hex stock or other suitable tool (J-22839). Position diaphragm on front plate, with long fold facing down). Place suitable seal protector tool (J-22733) over hub threads, apply light coat of suitable lubricant to hub and seal in center plate, then guide center plate, seal first, onto hub. Lightly lube air valve plunger bearing surfaces (avoid lubing inner rubber grommet). Install vacuum "O" ring seal on shoulder of front plate hub, and insert valve plunger and return spring in base of front plate hub. Screw rear plate onto front plate hub, by hand (torque to 150 in. lbs.). Check travel of valve plunger with finger.

**2)** Assemble rear diaphragm to rear plate (place diaphragm lip in plate groove). Install rear diaphragm retainer. Apply talcum powder to inner wall of rear housing, and suitable

lubricant to scallop cutouts and rear housing seal. Assemble diaphragm and plate assembly into rear housing (align center plate bosses between rear housing lances). Using screwdriver, work outer rim of diaphragm into rear housing. Attach rear housing to suitable tool (as used during separation – J-23456). Insert diaphragm return spring. Place front housing over rear housing (note location of scribe marks). Apply downward pressure until diaphragm edge is fully compressed, then rotate bar clockwise to lock housings. Remove from tool. Bend four tabs back to original position.

**3)** Dip poppet valve in clean alcohol and install in rear plate hub (small end first). Dip poppet retainer in alcohol and install it in poppet. Assemble retainer, filters, silencers, and return spring on valve rod. Dip valve plunger grommet in alcohol and install valve rod into plunger. Tap end of valve rod with plastic hammer to lock ball in grommet. Press filters and silencers into hub and install outer retainer. Assemble silencer in dust boot, wet boot with alcohol, and assemble on rod and over rear flange. Install check valve, if removed. Apply lubricant to piston end of hydraulic push rod and insert in cavity in front plate. Twist rod to eliminate air bubbles at reaction disc. Assemble seal over push rod and press into front housing recess.

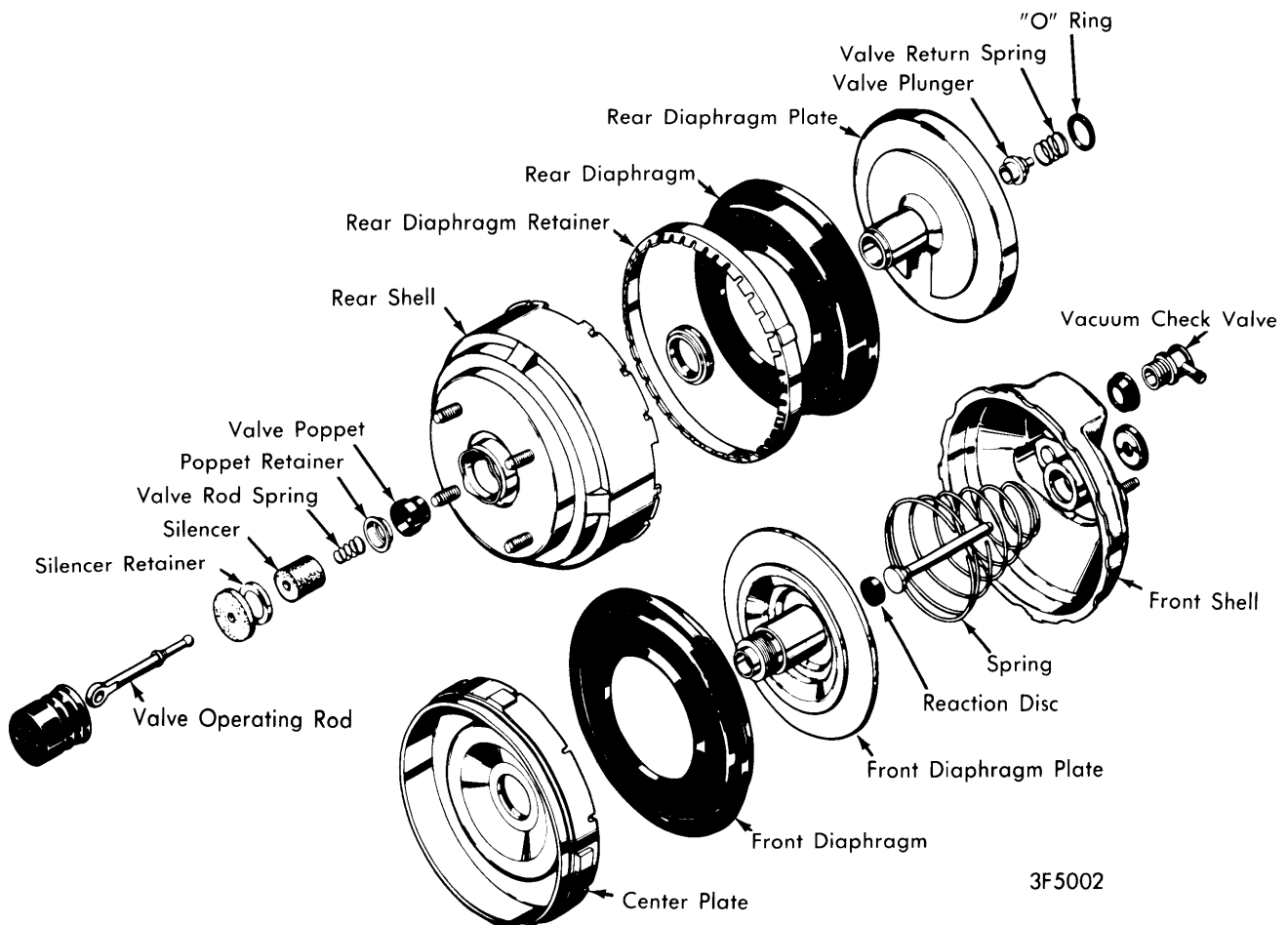

3F5002

**BENDIX TANDEM DIAPHRAGM UNIT**

# Power Brake Units

## BENDIX TANDEM DIAPHRAGM (Cont.)

### PUSH ROD ADJUSTMENT

Check or adjust push rod height whenever master cylinder and power unit are separated, or braking problems are diagnosed as possible push rod misadjustment. **NOTE** - Chrysler Corp. does not recommend push rod adjustment.

**Buick & Oldsmobile** - Place power unit in padded vise (front housing up). Insert master cylinder piston rod, flat end first, into piston rod retainer. Press on rod to ensure it is properly seated. Remove front housing seal, to eliminate vacuum from power unit. Place suitable gauge (J-22647) over piston rod in a position which will allow gauge to be moved left or right without contacting studs. If rod is not within gauge specifications, and push rod is not equipped with an adjusting screw, push rod must be replaced. If equipped with an adjusting screw, adjust push rod height to step on gauge.

**American Motors** - Using a suitable adjusting gauge (J-7723-01), check and adjust push rod height to 1.185-1.200" using end screw on push rod.

**Chevrolet** - Place top of suitable gauge (J-21183) over push rod. If out of adjustment, turn adjusting screw in or out as required to just touch top of gauge.

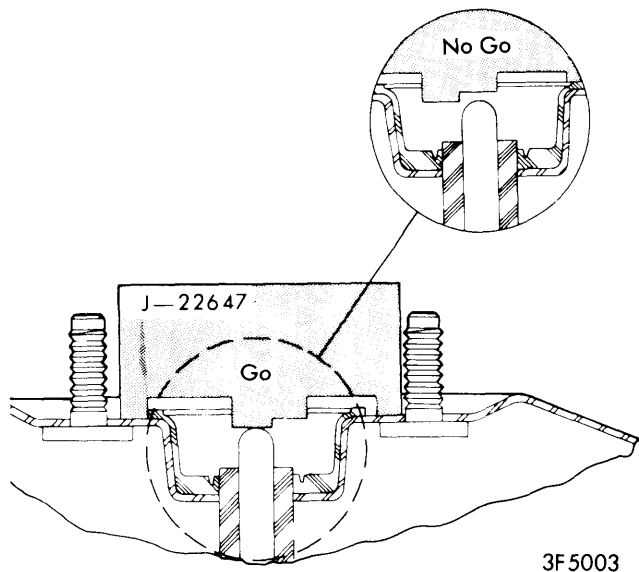

BUICK & OLDS PUSH ROD GAUGE

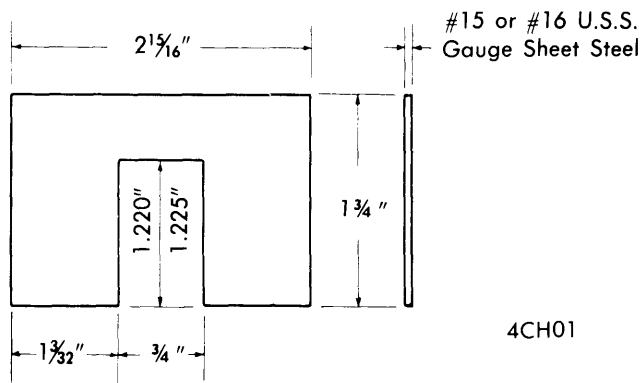

CHEVROLET PUSH ROD GAUGE