

## AMERICAN MOTORS POWER RACK & PINION

Pacer

### DESCRIPTION

Steering gear is a power rack and pinion design with integral gear and linkage. Gear consists of a tube and housing assembly which contains steering rack, piston, pinion shaft, valve body and adjuster plug. Thrust bearings and bushings support pinion in housing. A bushing and bulkhead assembly support rack in tube. Rubber boots are used to seal tie rod ends at tube and housing ends. Between the boots is a breather tube used to equalize pressure within boots during steering maneuvers. The rack piston operates within power cylinder and is centered between oil line fittings with wheels straight-ahead. Piston uses a single square seal. Pressure within cylinder is maintained by "O" ring and lip seals. Oil lines between tube and housing conduct fluid from valve body to power cylinder. The valve body is an open-center, three position, rotary-type valve providing neutral, left and right turn positions. Valve body consists of stub shaft, torsion bar and spool valve. Pinion locating lugs engage slots in stub shaft and torsion bar to couple pinion with valve body. Adjuster plug maintains pinion preload on conical thrust bearings.

### TESTING

#### PUMP PRESSURE

1) Check drive belt tension and adjust if necessary. Disconnect pump pressure hose and connect to suitable pressure tester valve and gauge. **NOTE** — The pressure gauge must be inserted between pump outlet and manual valve. Connect tester hose to power steering pump. Open manual valve and add fluid to reservoir if necessary.

2) Start engine and operate steering gear until fluid temperature is about 170°F. The initial pressure on tester gauge with valve open should be 80-125 psi. If pressure is in excess of 200 psi, check hoses for restrictions. Fully close and open manual test valve three times and record highest pressure each time. **CAUTION** — Do not hold valve closed longer than five seconds.

3) If pressures are within specification, and range of readings are within 50 psi of each other, pump operation is satisfactory. If pressures recorded are high, but do not repeat within 50 psi, flow control valve is sticking. Remove and clean valve and inspect for burrs or worn components. If fluid contains some dirt, flush entire system. If exceptionally dirty, both

pump and steering gear should be disassembled and cleaned. If pump pressure is within specifications, open test valve and turn steering wheel to right and left stops while observing pressures. If pump output cannot be met at each stop, gear is leaking internally and must be serviced.

Application	Psi
No Load Pressure at Idle.....	80-125
Turning Load.....	400
Full Stop.....	1100-1200

### REMOVAL & INSTALLATION

Removal and installation of power steering gear is the same as the manual steering gear, except for fluid hoses. See *American Motors Rack & Pinion Steering Gear* in this Section.

### OVERHAUL

#### PRE-DISASSEMBLY INSPECTION

Mount gear in a soft jaw vise, clamping on housing only. Cut boot clamp at housing and move boot to expose rack teeth. Clean rack teeth and examine for chips, cracks, flaking or worn teeth. If any of these conditions exist, replace entire gear assembly. **NOTE** — Do not replace gear if rack teeth have machining marks or appear bright or shiny. These conditions are normal. Remove coupling, adjuster plug and lock nut. Remove valve body assembly by pulling straight out on stub shaft. Do not disassemble valve body. Remove pinion shaft with pliers, pulling on drive tang and rotating counterclockwise. Inspect pinion for same wear conditions as rack teeth and replace gear assembly as required.

#### DISASSEMBLY

1) Remove housing contraction plug using a brass rod inserted through pinion bushings. Use same brass rod to remove lower pinion bushing and preload spring. Center rack in housing and install pinion shaft. Install valve body and adjuster plug, hand tighten plug only. **CAUTION** — Valve body must be seated in housing by pressing on valve body with thumbs, do not press on stub shaft. Mark tie rod tubes for reassembly reference and loosen tube clamp nuts. Remove tubes and tie rod ends from inner tie rods. Remove boots and slide shock

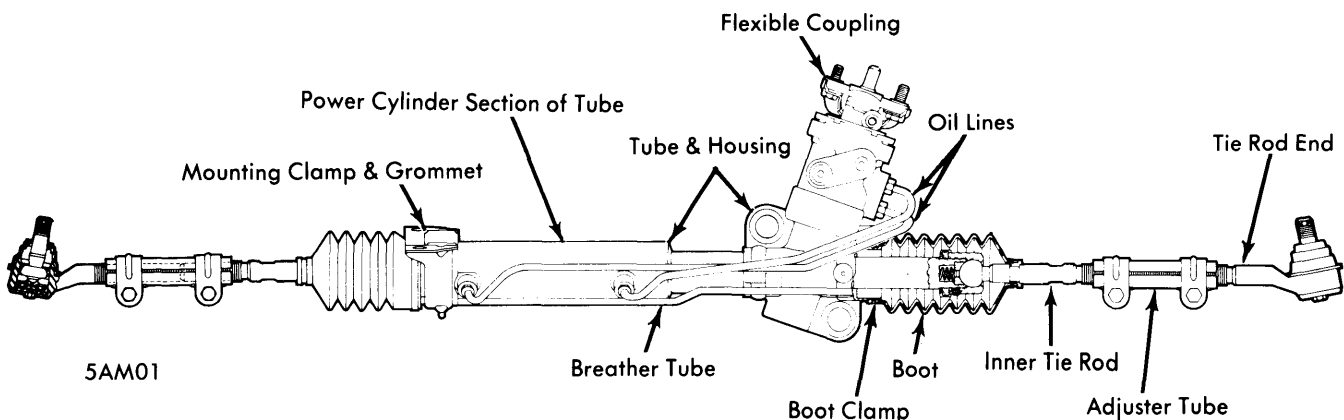

**POWER RACK & PINION STEERING GEAR ASSEMBLY**

## AMERICAN MOTORS POWER RACK & PINION (Cont.)

dampers off jam nuts. Remove gear from vise, clamp inner tie rod housing in vise and loosen jam nut. **CAUTION** — Inner tie rod housing must be held in vise to prevent damage to rack, pinion, stub shaft, or valve body. Repeat procedure for other side.

2) Loosen, but do not remove, each housing set screw. Mount gear in vise and remove inner tie rod housings, tie rods, ball seats, springs, jam nuts and shock damper rings. Remove adjuster plug and pull out stub shaft assembly. Remove pinion shaft by pulling with pliers on drive tang. Remove pinion thrust bearing, conical thrust races and support washer. Mark position of breather tube, mounting clamp and grommet for reassembly reference, then remove as required.

3) Remove bulkhead retaining ring by inserting a punch in access hole, lifting ring up and prying out with a screwdriver. Avoid scratching tube bore when removing ring, remove any burrs before removing rack assembly. **NOTE** — Do not remove rack unless a new inner rack seal is available as seal lip is cut by rack teeth during removal. Pull rack from tube, as rack is removed, rack piston will force bulkhead out of tube. Separate bulkhead from rack. Remove plastic rack bushing from housing. Insert a knife blade under bushing and pry upward, then pull bushing out with pliers.

4) Remove inner rack seal using suitable remover tool (J-25507). Insert tool in housing bore with legs of tool toward seal, push on tool until it rests on seal, then use a 12" brass rod to drive seal from housing. Invert gear in vise and drive out upper pinion bushing and pinion shaft seal with a socket.

### SUB-ASSEMBLY DISASSEMBLY

**Bulkhead & Rack Piston** — Remove outer "O" ring and two inner lip type seals from bulkhead. Note position of seals for correct reassembly. On rack piston, use a knife to remove seal from piston. Avoid scratching piston when removing seal.

**Adjuster Plug Assembly** — Remove thrust bearing retainer, being careful not to damage needle bearing bore. Remove spacer, bearing and races. Remove plug "O" ring seal. Remove stub shaft seal retaining ring, dust seal and oil seal. Remove needle bearing using suitable remover-installer tool (J-6221).

**Valve Body & Stub Shaft Assembly** — **NOTE** — Components are precision built with selective fitted parts and hydraulically balanced during manufacture. Disassemble unit only if seals need replacing. If any valve parts other than seals need replacing, replace entire valve body assembly. Hold valve body with stub shaft pointing down. Lightly tap shaft against bench until shaft cap is free of valve body. Pull shaft out until cap clears valve body (about 1/4"), but do not pull beyond 1/4" or spool valve may become cocked in valve body. Carefully disengage spool valve pin and remove stub shaft. Remove spool valve by pushing and rotating valve. Remove damper "O" ring from spool valve. Remove four seal rings from valve body only if severely worn.

### CLEANING & INSPECTION

Wash all parts, except nylon and rubber parts, in clean solvent. Check all parts for cracks, porosity, dents, distortion, chipped or worn conditions. Check for evidence of leakage between torsion bar and stub shaft, replace valve and shaft assembly if unit leaks. Examine machined surfaces of stub shaft, valve spool, and inner surface of valve body for nicks, burrs and wear spots. If slight surface irregularities cannot be cleaned up with crocus cloth, replace complete valve and shaft assembly. If small notch in valve body skirt is worn, replace assembly. Lubricate valve spool with power steering fluid and check fit in valve body (without "O" ring). If spool does not rotate freely without binding, replace valve and shaft. Small flat spots on sides of spool valve drive pin head are normal.



INSTALLING INNER RACK SEAL

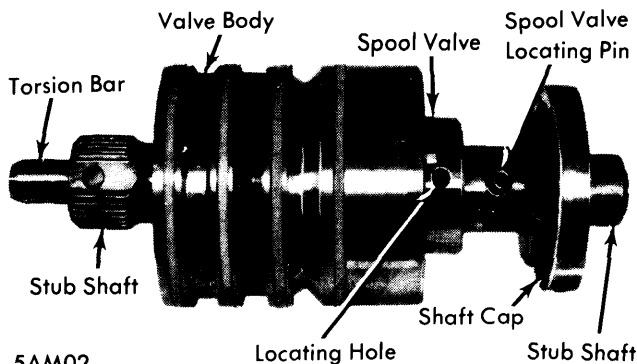

VALVE BODY, STUB SHAFT, & SPOOL VALVE

### REASSEMBLY

1) Install split type nylon rack bushing. Install rack seal as shown in illustration. Seal lip must face rack piston and seal metal surface facing away from rack piston. Slide seal and paper protector over rack teeth, then remove paper and push seal against piston. Apply lubricant to outside diameter of inner rack seal and bulkhead retaining ring groove in tube. Coat rack teeth with water-resistant lithium base EP-type chassis lubricant. Dip rack piston seal in power steering fluid and install seal, do not over-stretch or twist seal when installing. Install suitable seal protector (J-25508) in open end of tube and insert steering rack through protector and tube. Insert rack in tube as far as possible so piston will start inner rack seal into its seat in tube end. Bottom seal in seat using piston as a seal driver.



# Power Steering

## AMERICAN MOTORS POWER RACK & PINION (Cont.)

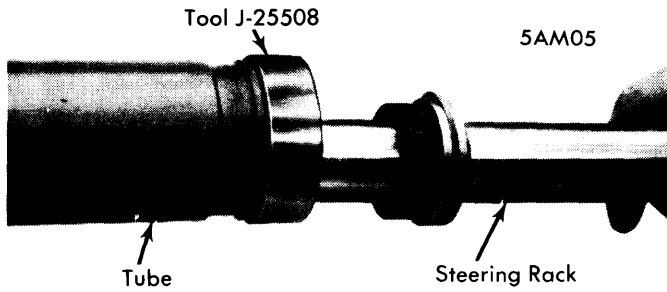

**INSTALLING STEERING RACK**

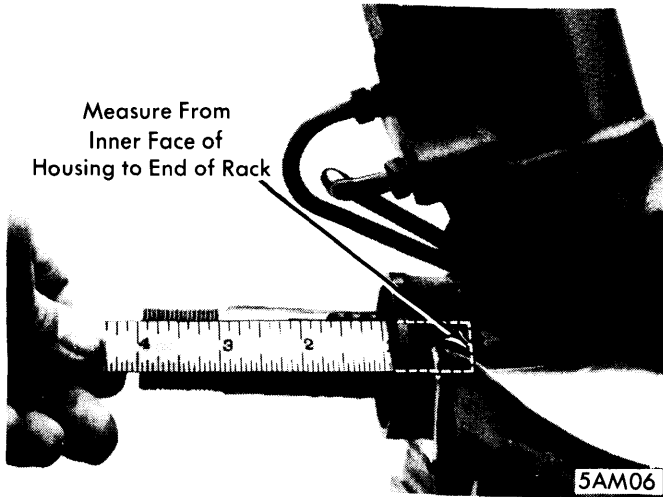

**CENTERING STEERING RACK**

2) Install upper pinion bushing (chamfered side down), and start pinion shaft seal, with lip facing bore, into seat in housing. Place support washer on top of pinion shaft seal. Tap on support washer with a hammer and socket until seal and washer are seated in housing. Lubricate pinion thrust bearing and races with Vaseline and install on shaft. *NOTE* — Install pinion shaft in following sequence to ensure correct centering of rack and pinion. Position rack teeth parallel to housing bore and set end of rack four inches from machined inner face of housing (see illustration). Install pinion in housing with drive pin located between three and four o'clock positions (see illustration). Push pinion in until it bottoms in housing. Center rack to four inch setting, now pinion shaft drive should be at 12 o'clock position; if not, repeat centering position.

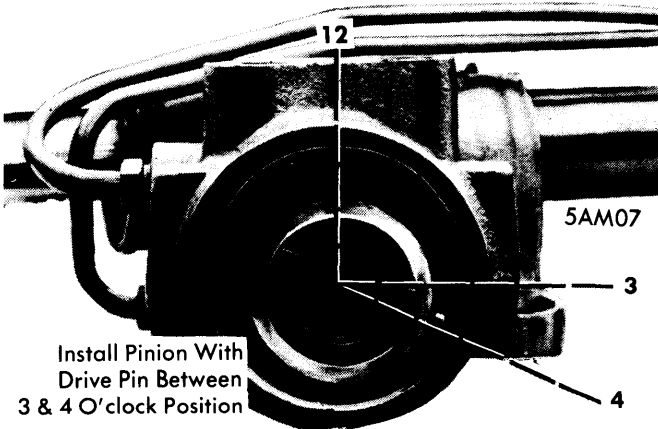

**CENTERING PINION SHAFT**

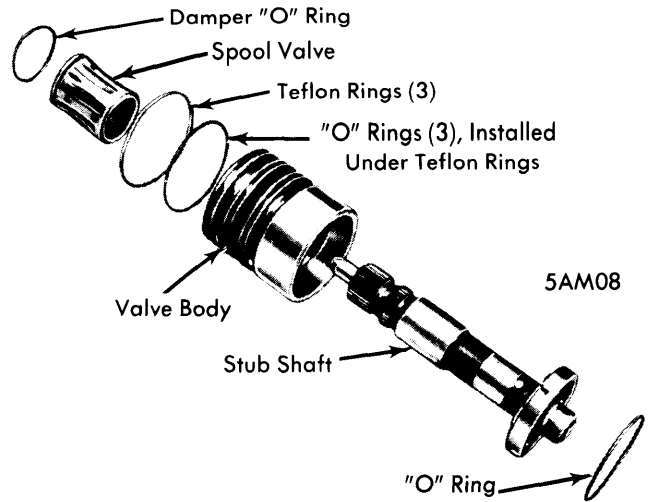

**VALVE BODY ASSEMBLY**

3) If valve body "O" rings and teflon rings were removed, install new rings and lubricate with power steering fluid. *NOTE* — Teflon rings may appear distorted, but high oil temperatures during operation will straighten them out. Lubricate spool valve damper "O" ring and install. Lubricate spool valve and valve body with power steering fluid and slide spool valve into body until shaft pin hole is visible from opposite end (spool valve flush with shaft cap end of valve body). Lubricate stub shaft assembly and install into spool valve until shaft pin can be placed into spool valve. Align notch in shaft cap with pin in valve body and press spool valve and shaft assembly into valve body. *NOTE* — Ensure that cap notch is mated with valve body pin before installing valve body into housing. Align notch in valve body with drive pin in pinion shaft and install valve body in housing. Be sure drive lugs on pinion shaft engage slots in stub shaft cap; when body is correctly installed, fluid return hole in housing will be exposed. *CAUTION* — Do not press on stub shaft to seat valve body; press directly on body using thumbs only.

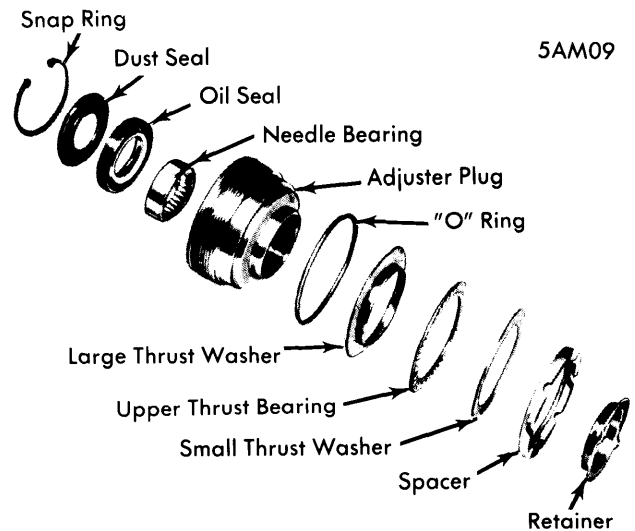

**ADJUSTER PLUG ASSEMBLY**

## AMERICAN MOTORS POWER RACK & PINION (Cont.)

4) Reassemble adjuster plug as follows: If replacing needle bearing, install new bearing on suitable tool (J-6221), with bearing manufacturer's identification facing tool. Drive bearing into plug until tool bottoms. Lubricate new stub shaft oil seal and using suitable tool (J-21554), install seal allowing clearance for dust seal and retaining ring. Install dust seal with identification facing out. Install snap ring and ensure ring is properly seated. Lubricate and install new "O" ring on adjuster plug. Assemble large thrust bearing race, bearing, small bearing race, and spacer on plug. Press retainer into needle bearing bore using a wood driver. Radial location of retainer dimples are not important.

5) Install adjuster plug in housing and tighten until fully bottomed. Adjust thrust bearing preload. Mark adjuster plug and housing after bottoming plug. Then measure back counter-clockwise  $\frac{3}{16}$  to  $\frac{1}{4}$ " and mark housing. Back adjuster plug off to second mark, then install and tighten lock nut as specified. **NOTE** — Be sure adjuster plug does not move when lock nut is tightened.

6) Install "O" ring and lip type seals in bulkhead. Lips of seals must face interior of tube. Install suitable seal protector (J-25509) over rack threads; then slide bulkhead over seal protector and into tube. Use a brass rod to tap on bulkhead until it bottoms against counterbore in tube. Install bulkhead snap ring so opening in ring is  $\frac{1}{4}$ " away from access hole in tube.

7) Mount gear in vise so EP lithium base chassis lubricant can be added to housing bore, do not overfill. Install preload spring with center hump of spring up against housing. End of spring must enter upper pinion bushing. Allow about  $\frac{1}{4}$ " of spring to extend past edge of housing. Using needle nose pliers, hold spring against housing and install lower pinion bushing. Chamfered end of bushing should face in toward pinion shaft, flat end facing out. Lightly tap on bushing and spring until both are seated. Install contraction plug in housing and seat in with a socket. To reassemble steering gear and linkage remaining components, reverse removal procedure.

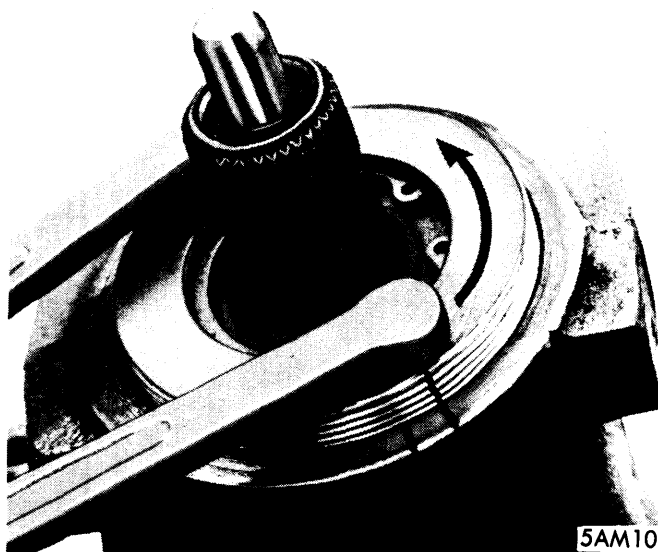

**PINION PRELOAD ADJUSTMENT**

### TIGHTENING SPECIFICATIONS

Application	Ft. Lbs.
Adjuster Plug Lock Nut.....	50-110
Adjuster Tube Clamp Nuts.....	18-27
Flexible Coupling Pinch Bolt.....	25-35
Flexible Coupling-to-Shaft Nuts.....	15-35
Inner Tie Rod Housing-to-Rack.....	5
Inner Tie Rod Housing Set Screw.....	4-5.8
Inner Tie Rod Housing Jam Nuts.....	90-110
Steering Gear Mounting Clamp Bolt.....	40-55
Steering Gear Mounting Bolt (at Housing).....	70-80
Tie Rod End Nut (at Steering Arm).....	45-60