

AMERICAN MOTORS

ALL MODELS

TIRE INFLATION (COLD)

Before checking wheel alignment, ensure that tires are inflated to manufacturers specifications, found on tire placard on inside of glove box door.

CASTER

Adjust by turning adjusting nuts on strut rod (see illustration). Turning nuts on rod will move lower control arm forward or backward for desired caster angle. Tighten adjusting nuts to 65 ft. lbs. after adjustment and jam nut to 55 ft. lbs.

CAMBER

Adjust by turning lower control arm inner pivot bolt eccentric. When desired camber setting is attained, tighten lock nut to 95 ft. lbs.

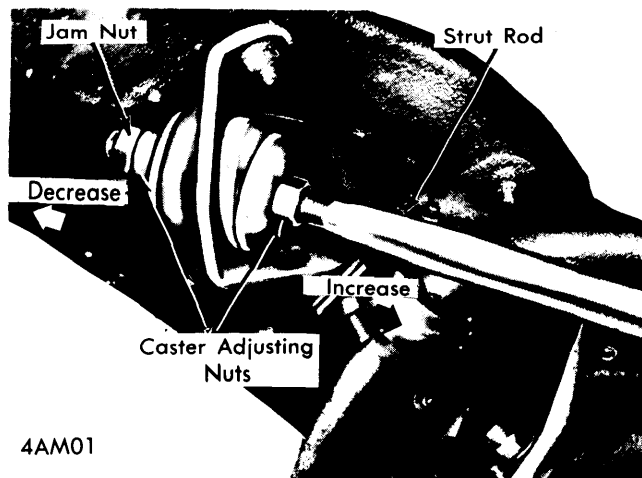

4AM01

CASTER ADJUSTMENT

CHRYSLER CORP.

ALL MODELS

TIRE INFLATION (COLD)

Inflate tires to manufacturers specifications, found on body pillar at rear of left front door opening.

RIDING HEIGHT

Valiant, Barracuda, Dart & Challenger Models – With car at curb weight and positioned on level floor, bounce front of car several times (releasing it on downward motion) and let settle. Measure from lowest point of torsion bar adjusting blade to floor and from lowest point of steering knuckle arm to floor. Difference between two measurements should be as specified and should not differ more than 1/8" between both sides of car. To adjust, turn torsion bar adjusting bolt clockwise to increase height and counterclockwise to decrease height. After adjustment is completed, bounce car and recheck both sides.

All Other Models – With car at curb weight and positioned on level floor, bounce front of car several times (releasing it on downward motion) and let settle. Measure riding height from lowest point of front torsion bar anchor (at rear of lower control arm flange) to floor and from lowest point of ball joint housing to floor. Difference between two measurements should be as specified and should not differ more than 1/8" between both sides of car. To adjust, turn torsion bar adjusting bolt clockwise to increase height and counterclockwise to decrease height. After adjustment is completed, bounce car and recheck both sides.

Front Suspension Height Limits ①

Car Model	Height Difference
Chrysler & Imperial	1"
Dodge	
Coronet & Charger	1 7/8"
Challenger	1 1/8"
Dart	1 7/8"
Monaco	1"
Plymouth	
Barracuda	1 1/8"
Fury	1"
Satellite	1 7/8"
Valiant	1 7/8"

① – Specifications are all ± 1/8". Maximum variation between sides of car is 1/8".

CASTER

Caster adjustments are made by rotating eccentric cam assemblies at inner end of upper control arm front and rear legs or by changing position of pivot bar. Remove all foreign material from exposed threads of cam adjusting bolt nuts or from pivot bar adjustment bolt nuts. Record initial caster reading before loosening cam bolt nuts or pivot bar nuts. Caster settings should be held as nearly equal as possible on both wheels.

CAMBER

Camber adjustments are made by rotating eccentric cam assemblies at inner end of upper control arm front and rear legs or by changing position of pivot bar. Remove all foreign material from exposed threads of cam adjusting bolt nuts or from pivot bar adjustment bolt nuts. Record initial camber reading before loosening cam bolt nuts or pivot bar nuts. Camber settings should be held as close as possible to specified setting.

Wheel Alignment

CHRYSLER CORP. (Cont.)

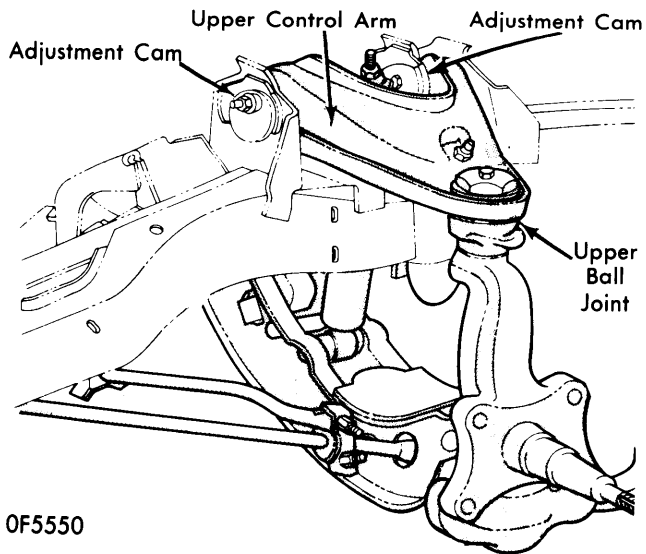

ECCENTRIC TYPE CAMBER/CASTER ADJUSTMENT

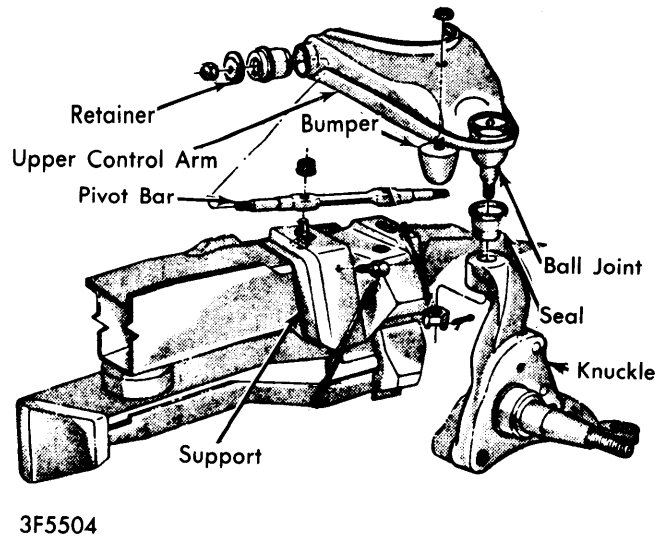

SLOTTED TYPE CAMBER/CASTER ADJUSTMENT

FORD MOTOR CO.

ALL MODELS

TIRE INFLATION (COLD)

Inflate tires to manufacturers specifications. Specifications are found on glove box door, rear edge of drivers door, or door pillar on drivers side.

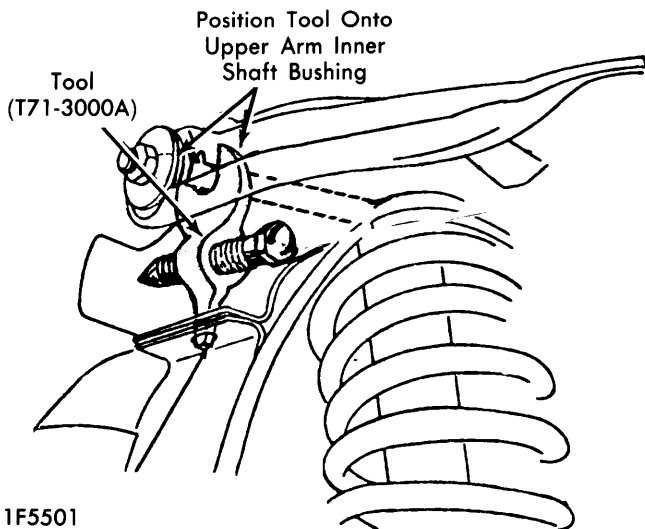

PINTO & MUSTANG CASTER & CAMBER ADJUSTMENT

PINTO & MUSTANG

CASTER & CAMBER

Install suitable tool (T74P-3000), one at each end of upper arm inner shaft and turn tool bolts in until bolt ends contact body metal. Loosen upper arm inner shaft-to-body attaching bolts.

Inner shaft will move inboard until stopped by tool bolt ends. Turn tool bolts in or out until caster and camber are within specifications. Tighten upper arm inner shaft-to-body attaching bolts. Loosen tool bolts, remove tools.

MAVERICK & COMET

CASTER

Caster is controlled by front suspension strut. To obtain positive caster, loosen strut rear nut and tighten front nut against bushing. To obtain negative caster, loosen strut front nut and tighten rear nut against bushing.

CAMBER

Camber is controlled by eccentric cam located at lower arm attachment to side rail. Loosen camber adjustment bolt nut at rear of body bracket. Spread body bracket at adjustment bolt area just enough to permit lateral travel of arm when adjustment bolt is turned. Rotate bolt and eccentric clockwise from high position to increase camber or counterclockwise to decrease camber. After adjustment, tighten lower arm eccentric bolt nut and strut front nut.

ALL OTHER MODELS

CASTER

Caster is adjusted by loosening bolts attaching upper suspension arm inner shaft-to-frame side rail. To obtain positive caster, tighten tool front hook nut or loosen rear hook nut. To decrease caster, tighten rear hook nut or loosen front hook nut. Check camber to be sure it did not change during caster adjustment. Tighten upper arm inner shaft attaching bolts.