

FORD MOTOR CO. POWER RACK & PINION

Ford Mustang

DESCRIPTION

Power steering gear is a hydraulic-mechanical unit using an integral piston and rack design to provide power assisted steering control. Internal valving directs pump flow and controls pressure to reduce steering effort. Unit contains rotary hydraulic fluid control valve integrated to input shaft and a boost cylinder integrated with rack.

ADJUSTMENT

RACK YOKE BEARING PRELOAD

NOTE — Steering gear must be removed from vehicle to perform following adjustment.

1) Clean exterior of gear thoroughly, then remove external pressure line assemblies from gear and drain fluid into a container. Attach gear to a suitable holding fixture. Mount suitable adapter (T74P-3504-R) to input shaft splines, then install an INCH lb. torque wrench (maximum capacity 30-60 INCH lbs.) to adapter.

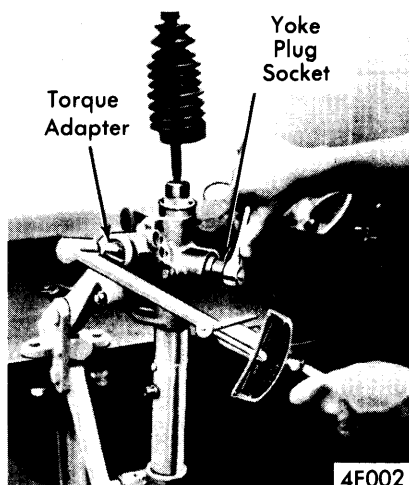

TIGHTENING YOKE PLUG

2) Using a suitable wrench, loosen yoke plug lock nut. Position rack to center of its travel. Install yoke plug spanner wrench (T74P-3504-W) on an INCH lb. torque wrench, then place assembly into drilled holes in yoke plug. Tighten yoke plug to 45-50 INCH lbs. **NOTE** — Make sure threads of yoke plug are clean to prevent false reading.

3) Back off yoke plug (a maximum of 45°), until torque required to turn input shaft is 7-15 INCH lbs. While holding yoke plug firmly with wrench, tighten lock nut. **CAUTION** — Do not allow yoke plug to turn while tightening lock nut, or preload will be affected. Recheck input shaft torque after tightening lock nut. Remove tools, then reinstall external pressure line assemblies, using new copper flare gaskets.

REMOVAL & INSTALLATION

STEERING GEAR

Removal — Disconnect negative battery terminal, then remove bolt retaining flexible coupling to input shaft. Turn ignition switch on "ON" position, then raise and support vehicle. Remove both tie rod end retaining cotter pins and nuts, then separate studs from spindle arms using a suitable ball joint separator tool. Remove inner front crossmember, then support gear and remove bolts securing gear to outer front crossmember. Lower gear slightly, then remove screw securing hose bracket to gear bracket. Disconnect pressure and return lines from gear valve housing, then plug lines to prevent entry of dirt. Remove gear from vehicle.

Installation — Support steering gear assembly near crossmember, then install and tighten pressure and return line fittings. Position hose bracket to gear bracket, install screw and tighten. Insert input shaft into flexible coupling, then position gear to crossmember. Install three bolts, insulator washers, and nuts, then tighten in following sequence: Right hand nut first, outer left hand nut second, and center nut last. **CAUTION** — Tightening two left hand nuts first may bend gear housing. Install inner front crossmember, then install tie rod ends to spindle arms. Install retaining nuts and tighten, then install cotter pins. Lower vehicle, then install bolt retaining flexible coupling to input shaft. Turn ignition key to "OFF" position, then connect negative battery terminal and remove coil wire. Fill power

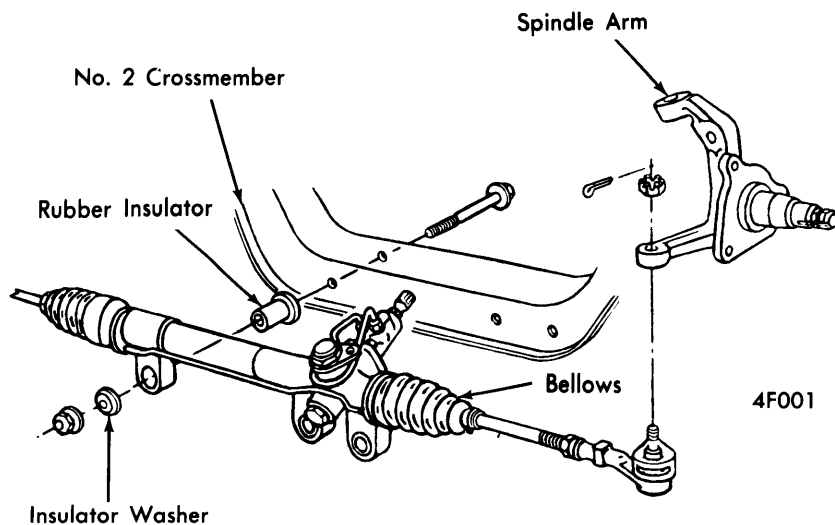

STEERING GEAR INSTALLATION

Power Steering

FORD MOTOR CO. POWER RACK & PINION (Cont.)

steering pump reservoir, then engage starter and cycle steering wheel to distribute fluid. Check fluid level, add as necessary. Install coil wire, start engine, cycle steering wheel, and check for leaks. Check wheel alignment, reset if necessary.

OVERHAUL

TIE ROD ENDS, BELLOWS, & TIE ROD BALL JOINT SOCKETS

Disassembly - 1) Mount gear in a suitable holding fixture, loosen jam nuts on outer end of tie rods, then remove sockets and jam nuts. Remove four clamps retaining bellows to gear housing and tie rods, then discard clamps. Drain lubricant and remove bellows and breather tube.

2) Using suitable drill fixture (T74P-3504-Z), insert a $\frac{3}{32}$ " drill into depth gauge on tool. **NOTE** - Depth gauge will set drill stop on drill bit to bore a $\frac{3}{8}$ " deep hole in ball socket and lock nut. Butt stop against tool, then tighten set screw securely. Tape cloths around rack end on both sides of ball socket to prevent metal chip contamination.

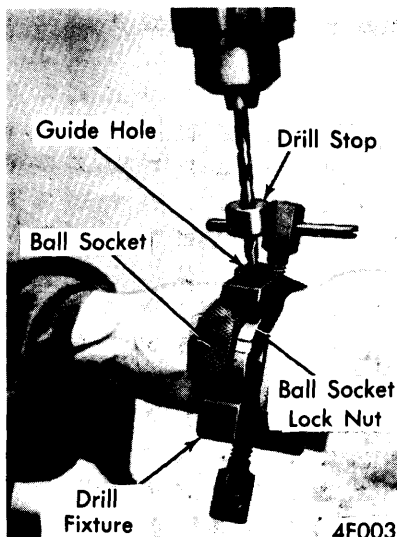

REMOVING BALL SOCKET RETAINING PIN

3) Install tool on ball socket, with pin in socket in line with guide hole in drill fixture. Position cone points of alignment and locking screws between locknut and ball socket, then tighten firmly. Place drill in fixture guide hole and drill out retaining pin. Remove tie rod and ball joint socket with suitable spanner wrench (T74P-3504-S). Remove lock nut, inner thrust bearing (seat) and rack spring from recess in end of rack. Examine all parts, replace as necessary.

Reassembly - 1) Install a new rack spring into recess in end of rack, then assemble ball socket to tie rod. Install a new inner thrust bearing (seat) in ball socket. Apply suitable lubricant to spring, thrust bearing, tie rod ball and ball socket. Thread a new ball joint lock nut on end of rack, then thread ball socket onto rack until tie rod articulation becomes stiff, and ball socket is tight.

2) Rotate rod at least seven times, then attach a suitable pull scale (T74P-3504-Y) to ball joint on tie rod end. Effort required to move tie rod should be 4-6 lbs. Tighten or loosen ball socket

until desired effort is obtained. Secure unit by holding ball housing with suitable tool (T74P-3504-S), and tightening lock nut against ball socket with suitable inner ball joint nut spanner wrench (T74P-3504-T). Recheck effort required to move tie rod, adjust as necessary.

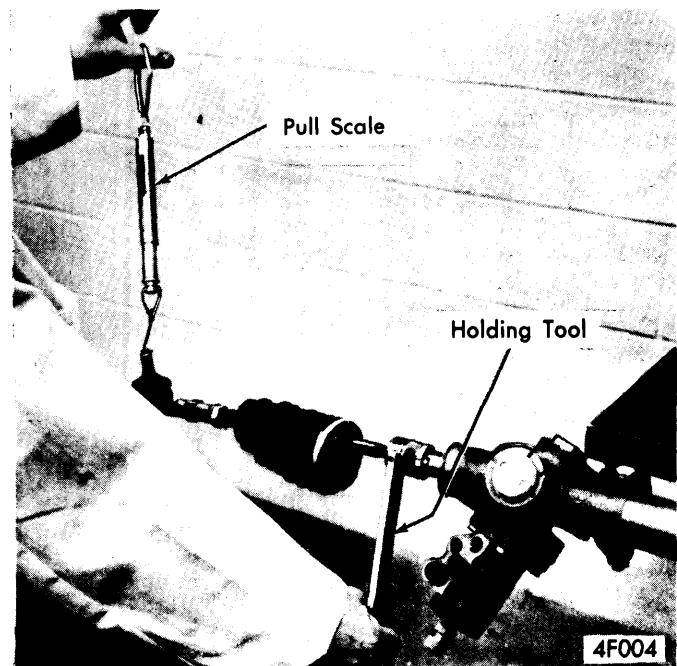

MEASURING TIE ROD MOVEMENT

3) Remove wrenches, then using procedure outlined in disassembly, install drill fixture on ball socket. Drill the hole on line of contact of lock nut and ball socket. **NOTE** - Hole must not enter notches of lock nut or old hole in ball socket. Insert retaining pin into drilled hole and tap in flush with ball housing and lock nut surfaces. With suitable staking tool (T74P-3504-X), stake metal of ball housing and lock nut over pin to secure tie rod adjustment.

4) Thoroughly clean rack and housing of any foreign material. To test pinning operation, use suitable tool (T74P-3504-T) to apply a reverse torque of 35 ft. lbs. on lock nut. Joint must not loosen under this torque application. Recheck articulation torque. Install bellows and breather tube. Install new clamps retaining bellows to gear housing, then use suitable tool (T63P-9171-A) to secure clamps. Install 2 1/2 oz. of suitable lubricant (D2AZ-19580-B) into each bellows, then install new clamps retaining bellows to tie rods. Install jam nuts and tie rod sockets on outer ends of tie rods.

INPUT SHAFT & VALVE ASSEMBLY

Disassembly - 1) Thoroughly clean exterior of housing, then mount assembly in a suitable holding fixture. Remove external pressure lines from valve and gear housing, then remove small flare gaskets from ports. Loosen yoke plug lock nut and yoke plug to relieve preload on rack. Using a $1\frac{5}{16}$ " wrench, remove pinion bearing plug. Install adapter (T74P-3504-R) on input shaft, then hold input shaft and remove and discard pinion bearing lock nut using a $\frac{3}{16}$ " socket.

FORD MOTOR CO. POWER RACK & PINION (Cont.)

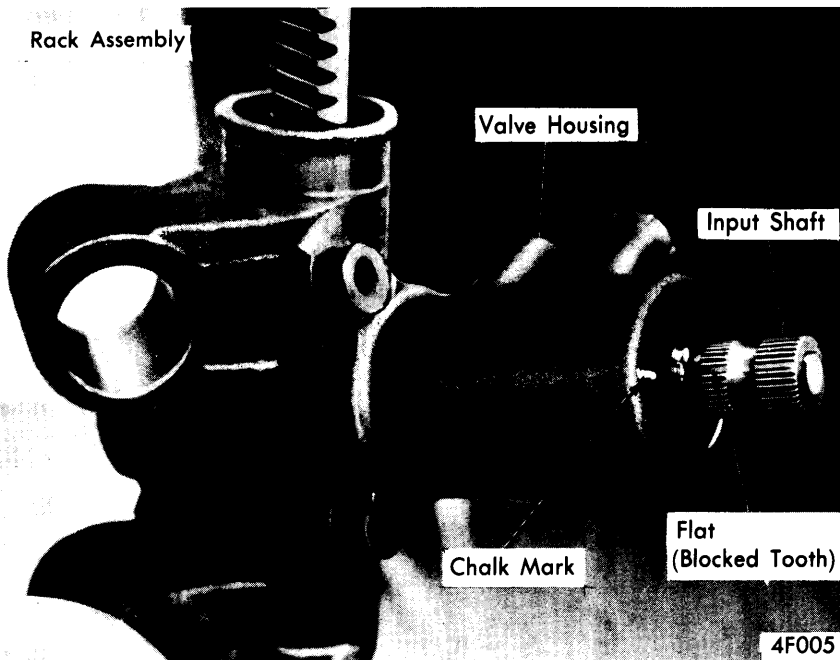

MARKING TOOTH POSITION

2) Remove bolts and washers retaining valve housing to gear housing. **NOTE** — Valve housing, input shaft dust seal, oil seal, support bearing, thrust washers and thrust needle bearing can be replaced without removing input shaft and valve from gear housing. Move rack to left stop, then using a piece of chalk or a file, mark position of blocked tooth on input shaft splines on housing face. Carefully work input shaft and valve assembly out of gear housing.

3) Using a slide hammer and suitable adapter, remove piston bearing from gear housing, then remove bearing to gear housing "O" ring seal. Remove valve housing to gear housing "O" ring seal, then remove input shaft oil seal from gear housing. Remove valve housing from input shaft and valve assembly by sliding housing over splined end of input shaft. Remove four Teflon "O" rings from assembly, taking care not to damage lands and grooves.

4) Remove input shaft thrust needle bearing, and two thrust washers from inside of valve housing. Using a slide hammer and adapter, remove input shaft support bearing from bore in valve housing, then remove oil seal. Using a sharp chisel, pry input shaft dust seal out of valve housing. If damaged, remove brass pressure and return line tube seats using a slide hammer and suitable adapter. **NOTE** — Seats may be removed and replaced without removing valve housing from gear housing.

Reassembly — 1) If removed, install tube seats in ports in valve housing. Install an input shaft oil seal in valve housing, with seal lip facing inside of housing, and making sure seal bottoms in bore. Fill input shaft dust seal bore in housing with ESA-M1C45-A type lubricant, then install dust seal. Lubricate input shaft support bearing with power steering fluid, then install into valve housing using suitable driver (T74P-3504-N). **NOTE** — Tool will control installation depth to prevent contact with seal.

2) Install Teflon rings on grooves on valve assembly. Lubricate two thrust washers and needle bearing with power steering fluid. Install bearing with a thrust washer on each side over input shaft. Lubricate assembly with power steering fluid, then insert assembly, splined end first, into suitable installing tool (T74P-3504-H). Position assembly over valve bore of housing, then push unit through until it bottoms and full spline passes through dust seal. Remove tools.

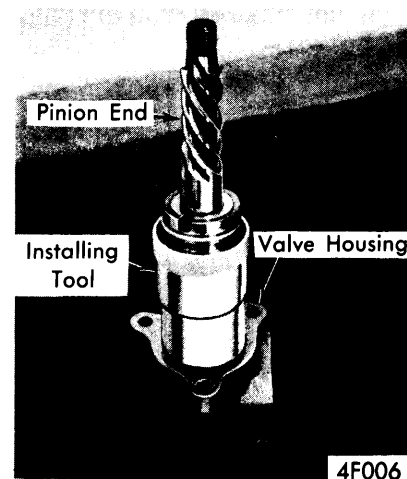

INSTALLING VALVE ASSEMBLY

3) Install valve housing to gear housing "O" ring seal on gear housing flange. Install an input shaft oil seal in gear housing, with lip of seal facing input shaft and valve assembly. Install pinion bearing in lower gear housing, through plug bore. Install an "O" ring seal around bearing adjacent to gear housing. Move rack to left stop, then install input shaft and valve

FORD MOTOR CO. POWER RACK & PINION (Cont.)

assembly in gear housing bore. **NOTE** — *Blocked tooth on input shaft splines must be in same position that was marked during disassembly.*

4) Install and tighten bolts retaining valve housing to gear housing. Install adapter on input shaft splines, then install pinion bearing lock nut on pinion shaft. Using a separate pinion bearing plug (other than plug used on assembly), drill a hole in cap, large enough to pass a $\frac{3}{16}$ " socket through. Thread modified plug into bore and tighten to hold bearing in place. While holding input shaft, tighten lock nut. **NOTE** — *Rack should be away from stop during this operation.* Remove modified plug.

5) Install proper pinion bearing plug and tighten. Stake plug in slots in gear housing. Do not align old stake marks with slots. Install external pressure lines and tighten, then install tube bracket with tabs engaged in slots on gear housing. Install yoke plug lock nut. Before tightening lock nut, set rack yoke bearing preload. See *Adjustment*.

GEAR HOUSING & RACK ASSEMBLY

Disassembly — 1) Remove tie rod and socket assemblies, lock nuts from both ends of rack, and input shaft and valve assembly. Remove yoke plug lock nut, tube bracket, and yoke plug. Remove yoke spring and yoke bearing from gear housing. Working from right side of gear housing, push rack in until it bottoms. Remove rack bushing lock nut, using suitable socket (T74P-3504-B).

2) Slowly pull rack from right side of housing, until rack piston contacts rack bushing. Apply pulling effort (do not hammer) on rack until bushing is removed from housing, then remove rack. Remove internal high pressure rack oil seal using suitable remover tool (T74P-3504-C). Remove Teflon "O" ring and rubber "O" ring from rack piston. Remove rack bushing oil seal by placing bushing and suitable tool (T74P-3504-E) in a vise. Remove oil seal with suitable remover tool and slide hammer. Remove rubber "O" ring from bushing.

Reassembly — 1) Place high pressure oil seal on suitable installer tool (T74P-3504-D) with lip spring facing tool. With gear housing in a vertical position, insert installer into right side bore of housing, then tap into place. Install rubber "O" ring in groove of rack piston, then place Teflon "O" ring over rubber "O" ring using suitable installer tool (T74P-3504-G).

2) Place a long protective sleeve (T74P-3504-K) over rack gear teeth to protect internal oil seal. Thread a short protective sleeve (T74P-3504-J) over threads on right side of rack. Lubricate Teflon "O" ring and protective sleeve with power steering fluid. Install smaller end of suitable sizing tool (T74P-3504-H) into right side opening of gear housing.

3) Place rack, gear tooth end first, into sizing tool. Push rack into housing until leading end engages internal oil seal. Position sizing tool so it compresses Teflon oil seal, and guides it into housing bore. Push rack in until protective sleeve protrudes from left side of housing. Remove sizing tool and protective sleeve from end of rack. Place a ball housing lock nut on left end of rack to prevent rack teeth from damaging internal oil seal.

4) Install rubber "O" ring on aluminum rack bushing, then install high pressure oil seal in rack bushing so that lip spring faces inside of bushing. Lubricate short protective sleeve on rack end, and "O" ring seal on bushing with power steering fluid. Start bushing, seal facing out, on rack. Pass bushing and seal over protective sleeve and into housing bore until lock nut threads are visible, then remove protective sleeve. Pass rack bushing lock nut rack and start it into threads in housing bore.

5) Place a ball housing lock nut on right side of rack. Insert suitable wrench (T74P-3504-B) over exposed end of rack and into housing bore. Engage lock nut and tighten. Install yoke bearing, spring and plug, then install input shaft and valve assembly. Install tube bracket with tabs engaged in slots on gear housing. Install yoke plug lock nut. Before tightening lock nut, set rack yoke bearing preload. See *Adjustment*. Install tie rod and socket assemblies.

TIGHTENING SPECIFICATIONS

Application	Ft. Lbs.
Pressure Line Fitting.....	16-25
Return Line Fitting.....	25-34
Hose Bracket-to-Gear Bracket Screw	7-12
Gear-to-Crossmember Mounting Bolt	80-100
Tie Rod End-to-Spindle Arm Nut.....	35-47
Tie Rod End-to-Tie Rod Jam Nut	35-50
Steering Fex Coupling Bolt	20-30
Yoke Plug Lock Nut.....	44-66
Pressure Line Fittings	
At Valve.....	10-15
At Power Cylinder (Gear Housing)	10-15
Valve Housing-to-Gear Bolts	12-15
Pinion Bearing Lock Nut.....	44-66
Pinion Bearing Plug.....	60-100
Rack Bushing Lock Nut.....	80-120
Tie Rod Ball Socket Lock Nut	25-35