

CHRYSLER CORP. CONSTANT CONTROL

Chrysler Corp. All Models

DESCRIPTION

Power steering gear consists of a gear housing containing a gear shaft with sector gear, a power piston with gear teeth broached into the side of the piston which is in constant mesh with the gear shaft sector, and a wormshaft connecting the steering wheel to the power piston through a U-joint type coupling. The wormshaft is geared to the piston through recirculating ball contact. Steering valve, mounted on top of steering gear, directs the flow of fluid through the system. Fluid is supplied to steering gear, by an engine driven constant displacement pump through a pressure hose. Oil is returned to pump reservoir from steering gear through a return hose.

LUBRICATION

Checking Fluid Level – Check at every oil change or 3 month intervals. Use only Power Steering Fluid, No. 2084329 or equivalent. **CAUTION** – DO NOT use Automatic Transmission Fluid. With steering gear and pump at normal operating temperature, fluid level should be within level indicated on dipstick.

ADJUSTMENT

GEAR SHAFT PRELOAD

Disconnect center link from steering gear arm. Start engine and run at idle speed. Turn steering wheel from one stop to the other, counting number of turns. Turn wheel back exactly halfway, to center position. Loosen adjusting screw until backlash is evident in steering gear arm. Feel backlash by holding end of steering gear arm between thumb and forefinger with a light grip. Tighten adjusting screw until backlash just disappears. Continue to tighten to 3/8 to 1/2 turn from this position and tighten locknut to 28 ft. lbs. to maintain adjustment.

CONTROL VALVE

1) Fill oil reservoir. Connect suitable pressure gauge between pump and steering gear. Start engine. Center valve until unit is not self-steering. Tap on head of valve body attaching screws to move valve body up on steering housing, and tap on end plug to move valve body down on housing. Bleed all air from unit by turning wormshaft back and forth through the travel several times.

2) Refill reservoir. With steering gear on center, tighten gear shaft adjusting screw until backlash in steering gear arm just disappears. Make sure gear shaft preload (see above) has been properly adjusted. Starting from a point at least one full turn of the wormshaft either side of center, torque at sector shaft required to turn unit through center at 2 RPM in each direction shall not exceed 20 ft. lbs. or vary more than 5 ft. lbs. from left to right.

3) Adjust torque to be equal in both directions by readjusting the valve. Tighten valve body adjusting screw to 200 INCH lbs. With gear at or near full turn in either direction, attempt to return unit to center by applying torque wrench at steering gear shaft. Hold wormshaft until cross shaft torque builds up to 50 ft. lbs. Release wormshaft and maintain a constant steady pull at 2 RPM on gear shaft. If cross shaft torque does not drop to 20 ft. lbs. maximum as unit passes through center, check for too much interior drag, binding valve lever, binding spool valve or tight cross shaft adjustment.

4) With unit under power, but with no load, torque required to rotate wormshaft through an included angle of 180° (90° either side of center) at 6 RPM (or one revolution every 10 seconds) shall be 6-10 INCH lbs. Disconnect test equipment.

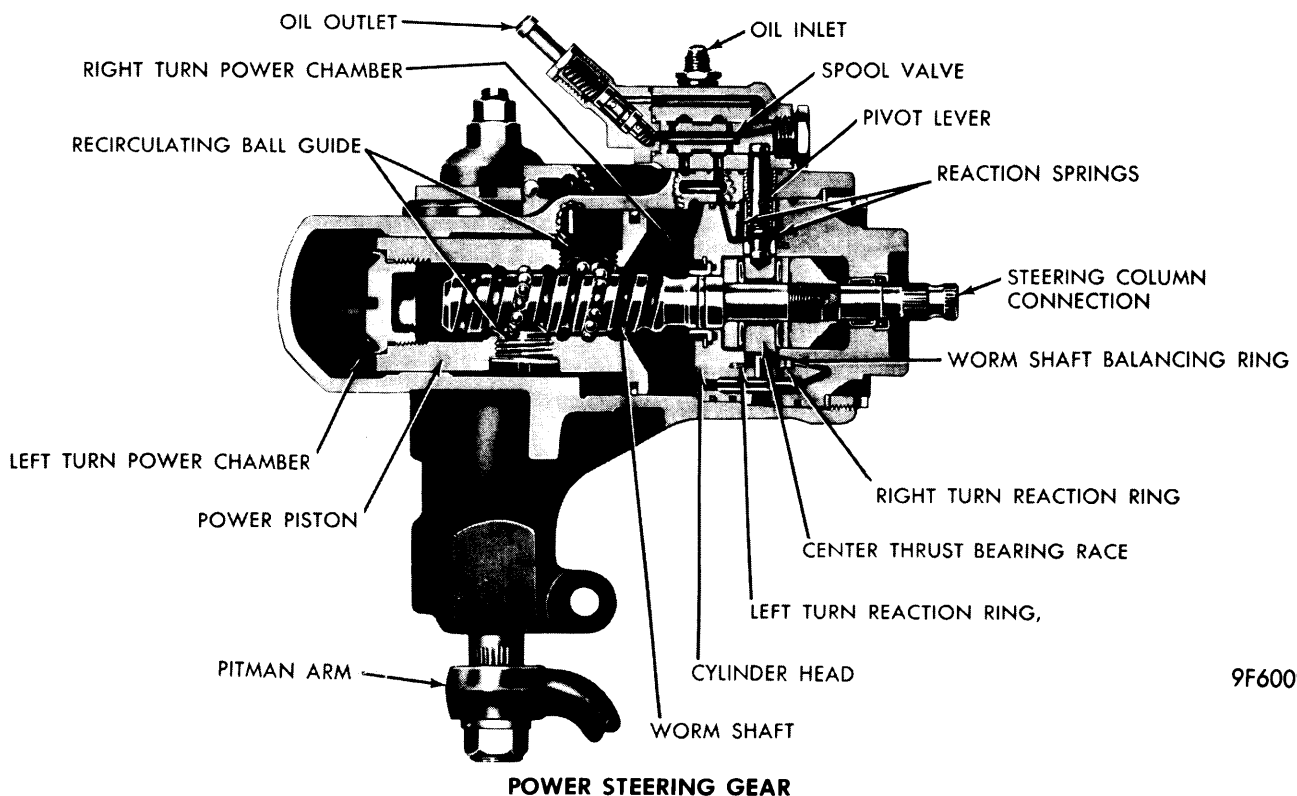

9F6009

CHRYSLER CORP. CONSTANT CONTROL (Cont.)

TESTING

PRESSURE TEST (ALL MODELS)

1) Check fluid level in pump reservoir and add fluid as required (see Lubrication). Check pump drive belt tension and adjust as required. Connect a pressure gauge with a shut-off valve (C-3309D) in the high pressure line between the pump and the steering gear. **NOTE** – Valve must be on *outlet side of gauge*.

2) Insert a thermometer in pump fluid reservoir, start engine and warm up fluid to 150-170°F (turning wheels from stop to stop will aid in this warming up – do not hold wheels against the stops).

3) With engine idling at 600 RPM and gauge valve open, note pressure as indicated on gauge while turning steering wheel from one extreme position to the other. Turn the wheels all the way to the stop momentarily and note pressure. This maximum pressure must be at least equal to the lower pressure shown for the particular pump in the specification table. If pressure is low, determine faulty unit by making test 4.

4) Close gauge valve momentarily and note gauge pressure while valve closed. If this pressure is less than higher pressure shown for the particular pump in the specification table, pump is faulty and should be reconditioned. If pressure is now satisfactory (but was low in step 3), steering gear is faulty and should be overhauled. Remove test gauge and restore original pump connections.

POWER STEERING PRESSURES

Car Model & Pump Type	Pressure (PSI)
Dart, Valiant	
.94 (198", 225", 318", 360")	900-1000
1.06 (225", 318", 360")	950-1050
Barracuda, Challenger	
.94 (318", 360")	900-1000
1.06 (318", 360")	950-1050
Satellite, Coronet, Charger	
.94 (225", 318", 400", 440")	1200-1300
1.06 (225")	950-1300
1.06 (318", 360", 400", 440")	1150-1300
Fury, Monaco	
.94 (318", 360")	1200-1300
1.06 (400", 440")	1150-1300
Chrysler, Imperial	
1.06 (400", 440")	1150-1300

TROUBLE SHOOTING

HARD STEERING

Tires improperly inflated. Oil level low. Pump belt loose. Caster and camber incorrect. Power steering pump and/or flow control valve faulty. Steering linkage binding. Gear shaft adjustment too tight. Valve lever damaged. Internal or external leakage of steering gear.

POOR RECOVERY

Tires improperly inflated. Steering linkage binding. Wheel alignment incorrect. Steering tube bearing damaged or worn. Steering column jacket and steering nut improperly aligned. Gear shaft adjustment incorrect. Column support spanner nut loose. Coupling not centered. Worm thrust

bearing adjustment incorrect. Cylinder head worm seal ring damaged or worm piston ring faulty. Burrs or nicks in reaction ring grooves in cylinder head or column support. Dirt or chips in steering gear. Piston worm rough or catching.

LEADS TO EITHER SIDE

Tires improperly inflated, Wheel alignment incorrect. Valve body not adjusted properly. Valve lever damaged. Column support spanner nut loose.

EXCESSIVE STEERING WHEEL FREEPLAY

Gear shaft improperly adjusted. Column support spanner nut loose. Worm thrust bearing out of adjustment. Coupling on worm shaft loose.

NO ASSIST (ONE DIRECTION)

Oil leak past worm shaft oil seal ring. Worm piston ring broken or worn. Piston end plug loose. Internal leakage in valve body. Reaction seal missing.

NO ASSIST (BOTH DIRECTIONS)

Belt slipping. Pump output low. Worm piston ring broken or worn. Piston end plug loose. Internal leakage in valve body.

TEMPORARY INCREASE IN TURNING EFFORT

Low oil level. Pump belt loose or oily. Steering linkage binding. Engine idle speed too low. Air in system. Pump output low. Gear shaft adjustment too tight. Valve lever damaged. Excessive internal or external leakage.

BUZZ IN NEUTRAL

Pump noisy. Hoses damaged or interfering with other units. Air in system.

CHUCKLING NOISE

Gear shaft adjustment incorrect. Worm shaft thrust bearing adjustment incorrect. Coupling on worn shaft loose. Worm and piston assembly worn.

METALLIC CLATTER OR TAPPING

Replace back pressure valve cushion.

KNOCK AT BRACKET STOP (ENGINE RUNNING)

Rubber stop worn or missing from pump bracket.

REMOVAL & INSTALLATION

STEERING GEAR

Removal – To avoid damage to energy absorbing steering column, it is recommended that the steering column be completely detached from floor and instrument panel before steering gear is removed. **NOTE** – See "Steering Columns" in this section for removal & installation procedures.

1) Remove steering column and disconnect power steering pressure and return hoses at centering valve on gear. Tie free ends of hoses above pump level to avoid loss of fluid.

2) From under vehicle, remove steering arm retaining nut and lock washer. Remove steering arm with suitable tool (C-4150). Remove three gear to frame retaining bolts. Remove gear (On Valiant and Dart with 318", engine must be raised).

CHRYSLER CORP. CONSTANT CONTROL (Cont.)

Installation — Reverse removal procedures and note the following: Place steering wheel in straight ahead position. Rotate worn shaft by hand and center sector shaft to mid point of its travel. Align master serration on sector shaft with splines on steering arm.

OVERHAUL

STEERING GEAR

Disassembly 1) Clean exterior of unit and install unit in suitable holding fixture. Drain steering gear through pressure and return connections by turning steering wormshaft from one extreme of travel to the other. Remove valve body attaching screws, and remove valve body and three "O" rings. Remove pivot lever and spring. **CAUTION** — Use care not to collapse slotted end of valve lever as this will destroy bearing tolerances of spherical head.

2) Loosen sector shaft adjusting screw locknut, and remove sector shaft cover spanner nut with a suitable tool (C-3988). Rotate wormshaft to position sector shaft sector teeth at center of piston travel. Loosen steering power train retaining nut with a suitable tool (C-3989). Place suitable tool (C-3786) on threaded end of sector shaft and slide tool into housing until both tool and shaft are engaged with bearings.

3) Turn worm shaft to full left turn position to compress power train parts. Remove power train retaining nut and housing head tang washer. With power train firmly compressed, pry on piston teeth with a screwdriver using gear shaft as a fulcrum and remove complete power train. **NOTE** — It is important, cylinder head, center race and spacer assembly and housing head be maintained in close contact with each other to eliminate possibility of reaction rings becoming disengaged from grooves in cylinder head and housing head and prevent center spacer separating from center race and becoming cocked in housing. This would make it impossible to remove power train without damaging spacer or housing.

4) Place power train vertically in a soft jawed vise. Raise housing head until worm shaft oil seal just clears top of worm shaft, position arbor tool (C-3929) on top of worm shaft and extending into oil seal. Keeping arbor in position, pull up on housing head until arbor is fully positioned in bearing, then remove head and arbor.

5) **CAUTION** — If worm shaft oil seal is to be replaced, perform operation with housing head assembled in steering gear housing. Remove large "O" ring from groove in housing head. Remove reaction seal from groove in face of housing head with air pressure directed into ferrule chamber. Inspect all grooves for burrs. Remove reaction spring, reaction ring, worm balancing ring and spacer.

6) Hold worm shaft from turning, turn nut to release staked portions from knurled section and remove nut. **NOTE** — Wire brush knurled sections to remove chips, then blow out nut and wormshaft to remove metal particles. Remove upper thrust bearing race (thin) and upper thrust bearing. Remove center bearing race. Remove lower thrust bearing and bearing race (thick). Remove lower reaction ring and spring. Remove cylinder head assembly.

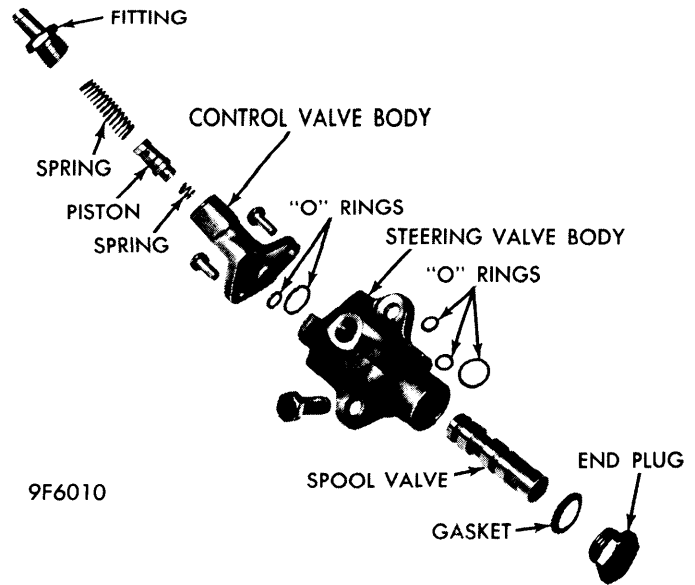

VALVE BODY

7) Remove "O" rings from outer grooves in cylinder head. Remove reaction "O" ring from groove in face of cylinder head by directing air pressure into oil hole between the two "O" ring grooves. Remove snap ring, sleeve and rectangular oil seal ring from cylinder head counterbore. Test operation of worm shaft. Torque required to rotate worm shaft throughout its travel in or out of piston must not exceed 2 INCH lbs. with a 15 pound side load. Worm should run in and out of piston under its own weight. **NOTE** — Worm and piston serviced as an assembly and should not be disassembled.

8) Test for excessive side play with piston held in vise (rack teeth up) and worm in its approximate center of travel. Vertical side play measured at a point 2-5/16" from the piston flange should not exceed .008" when end of worm is lifted with a force of 1 pound.

Reassembly — 1) Inspect condition of Teflon sealing ring located under cast iron ring and replace if necessary. To install cast iron piston ring, slide new piston ring into place in piston groove, then place piston and ring assembly in holding tool (C-3676) with lower part of piston and ring resting on land of tool. Press down on piston to seat ring in piston groove, forcing open-ends of ring out for ease of locking ring.

2) Place piston assembly in vertical position (worm shaft up) in a soft jawed vise. Inspect cylinder head ferrule oil passage for obstructions and lands for burrs. Lubricate two large "O" rings and install them in cylinder head grooves. Install worm sleeve seal, sleeve and snap ring (if removed). **CAUTION** — Make sure snap ring is seated in groove. Install lower reaction seal (O-ring) in cylinder head groove.

3) Slide cylinder head assembly (ferrule up) on worm shaft. **CAUTION** — Check worm shaft seal ring making sure gap is closed to avoid damaging the ring as the cylinder head moves against piston flange. Lubricate with power steering fluid, and install parts in the following manner; lower thrust bearing race (thick), lower thrust bearing,

Power Steering

CHRYSLER CORP. CONSTANT CONTROL (Cont.)

lower reaction spring (small hole over ferrule), lower reaction ring (flange up so ring protrudes through reaction spring and contacts reaction "O" ring in cylinder head), center bearing race, upper thrust bearing, upper thrust bearing race (thin), start worm shaft thrust bearing adjusting nut (do not tighten).

4) Turn worm shaft clockwise one-half turn. Hold worm shaft in this position with splined nut, then tighten nut to 50 ft. lbs. to prestretch worm shaft threads. Loosen adjusting nut. Place several rounds of cord around center bearing race. Make a loop in one end of cord, and attach a suitable distributor breaker arm spring scale to loop. Pulling cord will cause bearing race to rotate. Retighten worm bearing adjusting nut while pulling on cord with scale. When adjusting nut is tightened properly, reading on scale should be 16 to 24 ozs. (20 ozs. preferred while race is turning).

5) Stake upper part of worm shaft adjusting nut into knurled area of shaft. Hold a 1/4" flat end punch on centerline of worm shaft end at a slight angle to nut flange. Strike punch a sharp blow with hammer and test preload. **NOTE - If adjusting nut moved during staking operation, it can be corrected by striking the nut a glancing blow in the direction required to regain proper preload.** After retesting for proper preload, stake the nut at three more locations 90° apart around upper part of nut. To test total staking, apply 20 ft. lbs. of torque in each direction. If nut does not move, staking operation is correct.

6) Position spacer assembly over center race, engaging dowel pin of spacer in slot of race, and slot of spacer entered over cylinder head ferrule. This aligns valve pivot lever hole in center bearing race with valve pivot lever hole in center bearing spacer assembly. **NOTE - The small "O" ring for the ferrule groove should not be installed until after upper reaction spring and spacer have been installed.**

7) Install upper reaction ring on center race and spacer with flange down against spacer. Install upper reaction spring over reaction ring with cylinder head ferrule through hole in reaction spring. Install worm balancing ring (without flange) inside upper reaction ring. Lubricate ferrule "O" ring with vaseline and install in groove on cylinder head ferrule. If oil seal was removed from housing head, install a new seal. Lubricate and install reaction seal in groove in face of housing head with flat side of seal out. Install "O" ring in groove on housing head.

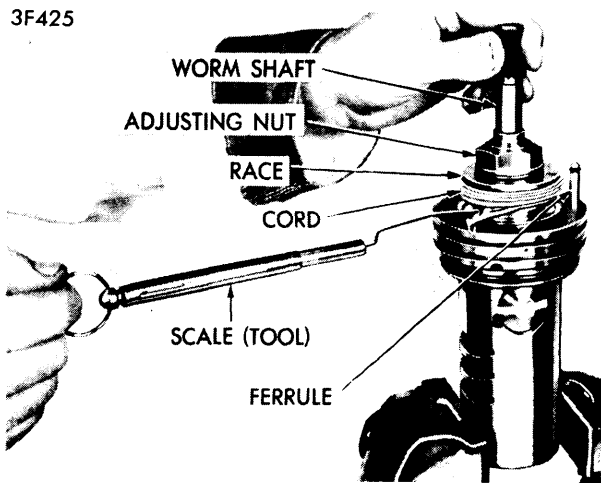
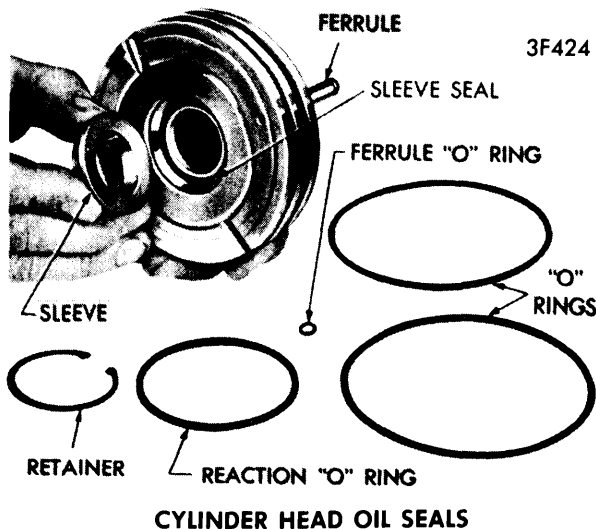

MEASURING CENTER BEARING PRELOAD

8) Slide housing head and arbor (tool C-3929) over the worm shaft engaging cylinder head ferrule and "O" ring and making sure reaction rings enter circular groove in housing head. Power train is now ready for installation in housing (Step 11). If it is necessary to replace gear shaft needle bearings, remove adjusting screw from sector shaft cover by turning adjusting screw clockwise until shaft becomes disengaged from cover, then slide adjusting screw out of "T" slot in end of shaft.

9) To remove sector shaft needle bearing assembly from housing, use a suitable removal tool (C-4183 with C-4171 handle) and drive or press bearing assembly into sector shaft teeth cavity of housing. To install a new bearing assembly, use a suitable installer tool (C-4155A with C-4171 handle). Press or drive until shoulder of tool stops on housing. Do not replace sector shaft oil seal unless necessary. To remove oil seal, pry out grease retainer, remove oil seal snap ring, and seal retainer, now pry out oil seal. Use care to avoid scratching seal bore.

10) Insert gear shaft, and adjusting screw into cover, and using an Allen wrench thru threaded hole in cover, turn screw counterclockwise to pull shaft completely into cover.

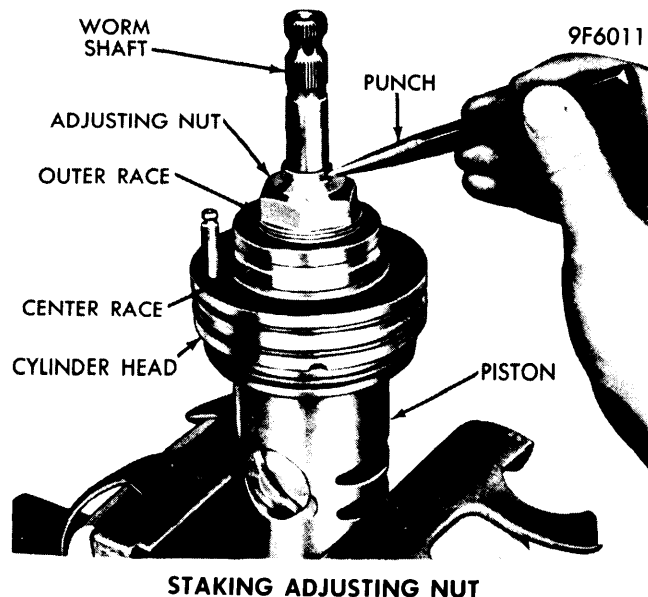

Power Steering

CHRYSLER CORP. CONSTANT CONTROL (Cont.)

11) Lubricate power train bore of housing and install power train assembly. To keep reaction rings from coming out of their grooves keep worm turned fully counterclockwise. Piston teeth must be facing to the right and valve lever hole in center race and spacer must be in the "up" position. **CAUTION** - Make sure cylinder head is bottomed on housing shoulder. Align valve lever hole in center bearing race and spacer exactly with valve lever hole in gear housing. Install valve pivot lever (double bearing end first) through hole in steering housing to engage center race and spacer (**CAUTION** - Slots in valve lever must be parallel to worm shaft to engage anti-rotation pin in center race), lightly tap on end of lever with wooden handle of hammer or screwdriver to seat lower pivot point in center race. Center lever in hole in housing by turning housing head (tap on reinforcing rib with hammer and drift).

12) Install housing head tang washer to index with groove in housing. Install spanner nut and tighten to 150-250 ft. lbs. Make certain valve lever remains centered in hole in housing. **NOTE** - Turn worm shaft until piston bottoms in both directions and note valve lever action. Lever must be in center of hole and snap back to its center position when worm torque is relieved. Install valve lever spring (small end first). Set power piston at center of travel, install gear shaft and cover assembly with sector teeth indexed with piston rack teeth. **CAUTION** - Make certain that cover "O" ring is in place on housing. Install cover spanner nut and tighten to 110-200 ft. lbs.

13) Install valve body on housing making sure valve pivot lever enters hole in valve spool. Be sure "O" ring seals are in place. Tighten valve mounting screws to 7 ft. lbs. Install new gear shaft seal followed by seal back-up washer and snap ring and a new grease retainer.

14) If new worm shaft and piston assembly has been installed, master serration on power steering gear worm shaft spline must be machined to properly center steering shaft coupling. To file a master serration, power steering gear must be assembled and worm shaft centered in its travel. With steering gear in its normal upright position remove one tooth of the spline at the 12 o'clock position, using a suitable file.

GEAR SHAFT OIL SEAL

NOTE - Gear shaft oil seal may be replaced without removing steering gear from vehicle. Remove steering arm nut. Disconnect steering gear arm from sector shaft. Slide threaded adapter (SP-3056 - Tool C-3350A) over end of gear shaft and thread tool nut (SP-3610) on gear shaft. Maintain pressure on threaded adapter with tool nut while screwing adapter far enough to engage metal portion of grease retainer. Place the two half rings (SP-1932), and tool retainer ring over both portions of the tool. Turn tool nut counterclockwise to remove retainer. Remove oil seal snap ring and seal back-up washer. Remove inner seal in same manner and using same tools as for grease retainer. Place new oil seal on flat surface (lip down), lubricate inner diameter with power steering fluid and insert seal protector sleeve, position seal on gear shaft (seal lip in). Place tool adapter (SP-3828) with long step against new seal, slide it over shaft with seal lip toward housing. Install tool nut on gear shaft and tighten until shoulder of adapter contacts gear housing. Remove tool nut and adapter, install seal back-up washer and oil seal snap ring (sharp edge out). Position grease retainer in housing bore. Place tool adapter (SP-3828) with short step of lip against seal. Install tool nut on gear shaft and tighten tool nut until shoulder contacts gear housing. With steering gear and wheels in straight ahead position, install steering gear arm and nut. Tighten nut to 180 ft. lbs.

TIGHTENING SPECIFICATIONS

Application	Ft. Lbs.
Gear Housing-to-Frame Bolt.....	100
Cross Shaft Adjusting Screw Lock Nut.....	28
Cross Shaft Cover Nut.....	150
High Pressure Hose Fitting	
Pump End Fitting.....	290 INCH Lbs.
Gear End Fitting.....	230 INCH Lbs.
Steering Arm Nut.....	175
Housing Head Spanner Nut.....	200
Valve Body Attaching Bolts.....	8
Valve Body End Plug.....	50
Steering Wheel Nut.....	60