

1969-73 DELCO-MORAINE SINGLE PISTON DISC

Buick (1969-73)
 Cadillac (1970-73)
 Chevrolet, Exc. Corvette (1969-73)
 Oldsmobile (1969-73)
 Pontiac (1969-73)

DESCRIPTION

Single piston caliper is constructed from single casting, which contains one large piston bore in inboard section. Piston is formed from nickel-chrome plated steel. **NOTE** — Use of abrasives, or re-mechining piston, will destroy plating. There is no piston spring in bottom of caliper bore. Caliper is mounted on support bracket attached to suspension. **NOTE** — On some models caliper is connected directly to steering knuckle. Shoe and lining assemblies are constructed of stamped metal shoe with riveted lining. Outboard shoe and lining are thinner than inboard assembly and have ears at top and tab at bottom, bent at right angle to shoe. A cast iron rotor is used in conjunction with these disc brakes. It contains two machined braking surfaces, separated by ventilation fins. A groove is added to center of rotor braking surface to aid in reduction of brake noise.

ADJUSTMENT

Shoe wear is automatically compensated for by sliding caliper feature; therefore, no brake adjustment in service is required.

SERVICING

BLEEDING

See **HYDRAULIC BRAKE BLEEDING**, in this Section.

SHOE & LINING INSPECTION

Inspect linings any time wheel is removed. Frequent inspections are recommended if driving conditions result in frequent brake applications. Check both ends of outboard shoe, by looking in at each end of caliper (most wear normally occurs at these points). Also check thickness of inboard lining. Replace all linings if any lining reaches the following limits:

Application	Wear Limit
Buick	Within .020" of rivets
Cadillac & Oldsmobile	Approx. thickness of shoe
Chevrolet.....	Within 1/32" of shoe or rivets
Pontiac125"

SHOE & LINING REPLACEMENT

NOTE — Relining should be done using complete sets only.

Removal — Remove and discard two-thirds of brake fluid from master cylinder front reservoir. **CAUTION** — Do not remove brake line, or completely empty master cylinder, or it will be necessary to bleed the system. Raise vehicle and remove front wheels. Position "C" clamp on caliper (exc. Pontiac), with solid side of clamp resting against inside of caliper and screw-end of clamp against outboard shoe. Tighten clamp until caliper moves away from vehicle far enough to push piston to bottom of bore. This will allow shoes to back off from rotor surface. Remove "C" clamp. On Pontiac, using suitable lever, pry caliper outward as far as possible (this will push piston to

bottom of bore). **NOTE** — It is not necessary to remove brake hose during relining. Unbolt caliper from support bracket, or steering knuckle. **NOTE** — On Eldorado, remove cotter pin, loosen upper ball joint nut, and slip brake hose collar out of clip (slack gained will permit caliper removal without pulling hose). Lift caliper off rotor, remove shoes, and position caliper so that weight is taken from brake hose. Remove shoe support spring from cavity in piston. Using suitable tool (J-22835), or hand pressure (Pontiac), remove sleeves from inboard ears of caliper, and rubber bushings from all four caliper ears.

Installation — Using suitable silicone lubricant, coat and install new sleeves, new rubber bushings, bushing grooves, and small ends of bushings in all caliper ears. Attach shoe support spring to inboard shoe, and position in caliper. Press down on both ends of shoe until it is resting flat on piston, and support spring is resting on I.D. of piston. Position outboard shoe in caliper, engaging tab at bottom of shoe in caliper cutout and shoe ears over caliper ears, at top of shoe. Place caliper over rotor, aligning caliper ears with mounting holes. Start bolts through inboard caliper ears and mounting bracket. Ensure bolt ends pass under retaining ears on inboard shoe. Push bolts through to engage holes in outboard shoe and ears of caliper. Thread bolt into mounting bracket and torque to specifications. Add suitable brake fluid, to fill master cylinder within 1/8" of top. Pump brake pedal to seat linings against rotor. Using channel lock pliers, clinch upper ears of outboard shoe against caliper. After clinching, ears should be flat against caliper, with no clearance. **NOTE** — On Eldorado, place brake hose in clip and torque upper ball joint nut to 60 ft. lbs. Install front wheels and lower vehicle to floor. **CAUTION** — Ensure solid brake pedal and full master cylinder before moving vehicle.

ROTOR SERVICING

Lateral Runout — Adjust wheel bearings until all endplay is eliminated. Attach dial gauge, such that pointer is approximately one inch from rotor edge. Set gauge to zero and turn rotor through one complete revolution, noting gauge. See **Rotor Specifications for maximum allowable runout**.

Parallelism — Check thickness of rotor at four or more points around circumference. Make all measurements at same distance from edge of rotor. If thickness varies more than specified, refinish or replace rotor, as necessary.

NOTE — Rotor and hub are cast as integral assemblies on most vehicles; however, if they are separate components, it is allowable to replace each component as necessary.

1969-70 Brake Disc Specifications ①

Parallelism, All Except Pontiac.....	.0005"
Pontiac.....	.0007"
Runout, Buick & Pontiac.....	.004"
Oldsmobile.....	.005"
Chevrolet.....	.002"
Minimum Thickness, Buick.....	.8875"
Chevrolet.....	1.215"
Chevelle, Chevy Nova, Camaro.....	.965"
Pontiac.....	1.195"
Tempest, Grand Prix, Firebird.....	.960"
Olds. F-85, Cutlass, 442, Vista Cruiser.....	.965"
Olds. Delta, Ninety-Eight, Toronado.....	1.215"
Surface, Micro-Inches Buick, Chevrolet.....	30-50
Pontiac.....	20-60
Oldsmobile.....	30-40

1969-73 DELCO-MORAINE SINGLE PISTON DISC (Cont.)

1971-72 Brake Disc Specifications ①

Parallelism, All Except Cadillac, Pontiac0007"
Cadillac, Pontiac (Exc. Ventura II)0005"
Ventura II0007"
Runout, Buick, Skylark, GS, Sport Wagon004"
All other models005"
Cadillac0025"
Eldorado008"
Chevrolet005"
Oldsmobile, F-85, Cutlass, 442, Vista Cruiser004"
Delta 88, Custom Cruiser, Ninety-Eight005"
Toronado002"
Pontiac004"
Minimum Thickness, Buick, Skylark, GS & Sport Wagon965"
All other models	1.215"
Cadillac	1.215"
Eldorado	1.190"
Chevrolet	1.215"
Chevelle, Nova, Camaro965"
Chevy Vega440"
Oldsmobile, F-85, Cutlass, 442, Vista Cruiser965"
Toronado	1.170"
All other models	1.215"
Pontiac, Catalina, Grandville, Bonneville	1.215"
All other models965"
Surface, Micro-Inches, Buick	30-80
Chevrolet, Pontiac	20-60
Oldsmobile	30-50

1973 Brake Disc Specifications ①

Minimum Thickness After Refinish	
Buick — Century, Regal980"
Exc. Century, Regal	1.230"
Cadillac — Exc. Eldorado	1.220"
Eldorado	1.205"
Chevrolet — Exc. Impala, Vega980"
Impala	1.230"
Vega455"
Oldsmobile — Omega, Cutlass980"
88, 98	1.230"
Toronado	1.185"
Pontiac — Bonneville, Catalina, Grand Ville	1.240"
LeMans, Firebird, Grand Prix965"
Ventura980"
Discard Thickness	
Buick — Century, Regal965"
Exc. Century, Regal	1.215"
Cadillac — Exc. Eldorado	1.215"
Eldorado	1.190"
Chevrolet — Exc. Impala, Vega965"
Impala	1.215"
Vega440"
Oldsmobile — Omega, Cutlass965"
88, 98	1.215"
Toronado	1.170"
Pontiac — Bonneville, Catalina, Grand Ville	1.215"
LeMans, Firebird, Grand Prix965"
Ventura980"

1973 Brake Disc Specifications (Cont.)

Lateral Runout	
Buick — All004"
Cadillac — Exc. Eldorado005"
Eldorado008"
Chevrolet — All005"
Oldsmobile — Omega, Cutlass004"
88, 98005"
Toronado002"
Pontiac — All004"
Parallelism	
Buick — All0005"
Cadillac — Exc. Eldorado0007"
Eldorado0005"
Chevrolet — All0005"
Oldsmobile — All0005"
Pontiac — Exc. Ventura0007"
Ventura0005"

① — Light scoring, less than .015" in depth, will not be detrimental to brake operation. Turning or refinishing discs to remove scoring is not necessary.

REMOVAL & INSTALLATION

BRAKE CALIPER

Removal of caliper for overhaul is same procedure as for lining replacement, except it will be necessary to disconnect brake hose.

OVERHAUL

BRAKE CALIPER

Disassembly — Clean exterior of caliper with denatured alcohol and place on clean work surface. Remove brake hose, discarding copper gasket. Drain brake fluid from caliper. Use clean shop towels to pad interior of caliper and use compressed air introduced at caliper inlet, to remove piston. **CAUTION** — Use just enough air pressure to ease piston out of bore. Use screwdriver to pry boot out of caliper. Remove piston seal from its groove in caliper bore, using a piece of wood or plastic. **CAUTION** — Do not use a metal tool of any type for this operation. Remove bleeder valve from caliper.

Cleaning & Inspection — The boot, piston seal, rubber bushings, and sleeves are to be replaced each time caliper is overhauled. Clean all other parts in denatured alcohol. Dry parts with dry, filtered, compressed air. **NOTE** — Using lubricated shop air will leave a film of mineral oil on metal parts. This may damage rubber parts upon contact after reassembly. Check mounting bolts for corrosion, breaks in plating, or other damage. Do not attempt to clean bolts; replace them. Check outside diameter of piston for scoring, nicks, corrosion, worn or damaged plating. If surface defects exist, piston must be replaced. **NOTE** — Refinishing piston with abrasives is not acceptable. Piston bore must also be checked for major defects. Bore is not plated; therefore, minor corrosion can be polished with crocus or emery cloth. Thoroughly clean bore after polishing. Replace caliper if bore corrosion is not easily cleaned.

Reassembly — Lubricate bore in caliper and new piston seal with clean brake fluid. Position seal in caliper bore groove. Lubricate piston with clean brake fluid and assemble new boot into groove in piston with fold facing open end of piston. Insert

1969-73 DELCO-MORaine SINGLE PISTON DISC (Cont.)

piston into caliper bore, using care not to unseat seal. Do not force piston to bottom of bore. Position outer diameter of boot in caliper counterbore and seat, using suitable tool (J-22904). Check boot installation to ensure retaining ring (molded into boot) is not bent, and that boot is installed completely below caliper face. Install brake hose, using new copper gasket. **NOTE** — After overhaul is complete and caliper installed, it must be bled. See **HYDRAULIC BRAKE BLEEDING** in this Section.

COMBINATION VALVE

Combination valve is used on all disc brake equipped cars. Valve combines functions of front brake hold-off (metering) valve, rear brake proportioning valve, and hydraulic pressure differential switch. Valve is mounted on left front frame side-rail and is connected to master cylinder and wheel cylinders through hydraulic lines. Wiring harness connects electrical terminal of pressure differential warning switch to brake warning light on instrument panel. Hold-off section limits pressure to front disc brakes until rear drum brakes are activated. Proportioning section supplies outlet pressure to rear brakes after a predetermined input pressure has been reached. This prevents rear wheel lock-up on vehicles with light rear wheel loads. Certain models having heavy rear wheel loads do not have proportioning feature. This section also has by-pass feature which is designed to assure full rear system pressure in event of front brake failure. Pressure differential warning switch is designed to constantly compare front and rear system pressure. In event of failure of either system, warning light will come on and remain on until proper repair is made and pressure is applied to pedal (to develop 450 psi line pressure).

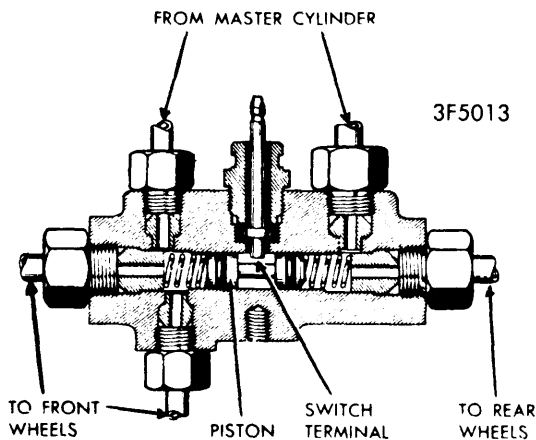

COMBINATION SWITCH (TYPICAL)

Testing Electrical Circuit — Disconnect wire from combination switch terminal and ground the wire. Turn ignition to "ON". Warning light should come on. If it does not, then bulb is burned out or electrical circuit is defective. Replace bulb or wiring as necessary. When light comes on turn ignition off and reconnect wire to combination switch.

Testing Warning Light Switch Section — Attach bleeder hose to either rear brake and immerse other end of hose in container with brake fluid. Ensure master cylinder is full. Turn ignition to "ON", open bleeder screw while pressure is applied to brake pedal. Warning lamp should light. Close bleeder

screw before pressure is released from pedal. Reapply pedal pressure (moderate to heavy). Light should go out. Repeat test on front system. Results should be the same. Turn ignition off. If lamp does not light on either system, but electrical circuit checked good, warning light switch portion of valve is defective.

Replacing Combination Valve — If any portion of combination valve is defective, entire valve must be replaced, as it is non-repairable. Bleed system.

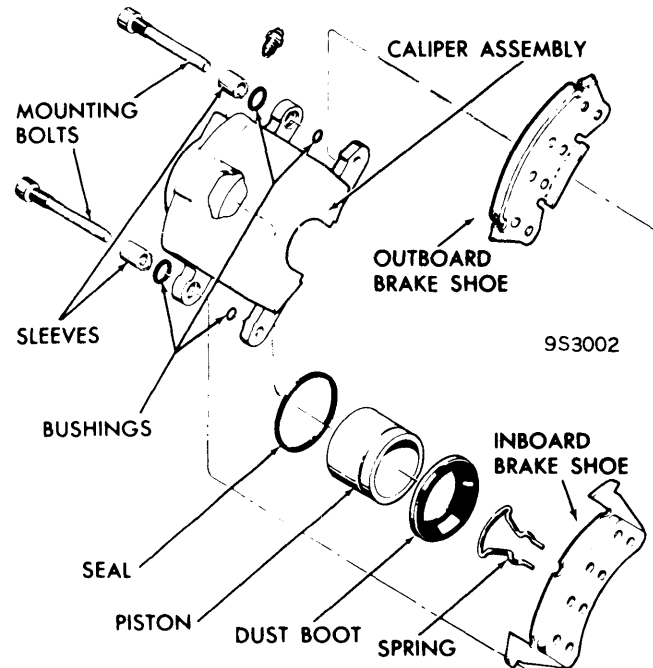

SINGLE PISTON CALIPER COMPONENTS

1969-70 TIGHTENING SPECIFICATIONS

Application	Ft. Lbs.
Caliper Mounting Bracket-to-Knuckle	
F-85, Cutlass, 442, Vista-Cruiser	70-90
Delta 88, Ninety-Eight	110-140
Buick & Pontiac	125
Caliper to Steering Knuckle	
Toronado	30-40
Caliper to Mounting Bracket	
Buick & Pontiac	35
Chevrolet	30
Oldsmobile	30-40
Bleeder Screw	65 INCH Lbs.
Wheel Lug Nuts	
Buick	70
Chevrolet	65
Oldsmobile F-85, Cutlass, 442, Vista Cruiser	60-80
Delta 88, & Ninety-Eight	65-85
Toronado	100-130
Pontiac	75
Tempest, Grand Prix, Firebird	70

1969-73 DELCO-MORAINE SINGLE PISTON DISC (Cont.)

1971-72 TIGHTENING SPECIFICATIONS

Application	Ft. Lbs.
Caliper to Mounting Bracket or Steering Knuckle	
Buick, Chevrolet, Pontiac	35
Cadillac	30
El Dorado	25-30
Oldsmobile, Except F-85, Cutlass, & 442, Vista Cruiser	40
Caliper Adapter Bracket to Steering Knuckle	
Oldsmobile F-85, Cutlass, 442, Vista Cruiser	140
Splash Shield & Mounting Bracket to Knuckle	
Pontiac - Upper	125
Lower	75
Bleeder Screw	65 INCH lbs.
Wheel Stud Nuts, Buick, Skylark, GS, &	
Sport Wagon	70
All Other Models	75
Cadillac	105
Chevrolet	70
Oldsmobile, F-85, Cutlass, 442, Vista Cruiser ..	80
Delta 88, Custom Cruiser, Ninety-Eight	85
Toronado	130
Pontiac, Catalina, Grandville, Bonneville	75
All Other Models	70

1973 TIGHTENING SPECIFICATIONS

Application	Ft. Lbs.
Brake Hose to Caliper	
Buick, Chevrolet, Omega.....	22
Cadillac.....	30 (Max.)
Oldsmobile - Cutlass, 88, 98	25
Toronado	35
Splash Shield and/or Mounting Bracket to Steering Knuckle	
Buick	125
Chevrolet.....	95
Oldsmobile.....	12
Pontiac - LeMans, Ventura - Upper.....	115
Bonneville, Catalina, Grand Ville, Firebird - Upper	15
Caliper to Mounting Bracket	
Buick, Chevrolet, Pontiac	35
Cadillac.....	30
Oldsmobile.....	40
Wheel Attaching Nuts	
Buick - Century, Regal	70
Exc. Century, Regal	75
Cadillac.....	130
Chevrolet - All.....	70
Oldsmobile - Omega, Cutlass	80
88, 98	85
Toronado	130
Pontiac - Bonneville, Catalina, Grand Ville.....	75
Exc. Bonneville, Catalina, Grand Ville.....	70