

## 1967-73 GENERAL MOTORS AUTOMATIC LEVEL CONTROL

Buick (1968-73)  
 Cadillac (1967-73)  
 Chevrolet (1967-72)  
 Pontiac (1967-73)

### DESCRIPTION

This pneumatic level control system automatically maintains correct rear trim height of the vehicle under varying load conditions. This is done by the system automatically regulating air pressure to special type shock absorbers. The system consists of a vacuum operated air compressor (with pressure regulator and integral storage tank), vacuum line to engine, air intake filter and lines, and a height control valve. The compressor is a two-stage type which generates air pressures up to 275 psi in the storage tank. A self-contained regulator valve is preset to maintain pressure to the height control valve of not more than 125 psi. The height control valve, linked to rear suspension, admits or exhausts air to the special shock absorbers as load variances cause a trim deflection of approximately 1/2". A built-in time delay system is incorporated to prevent system operation during normal ride suspension height changes.

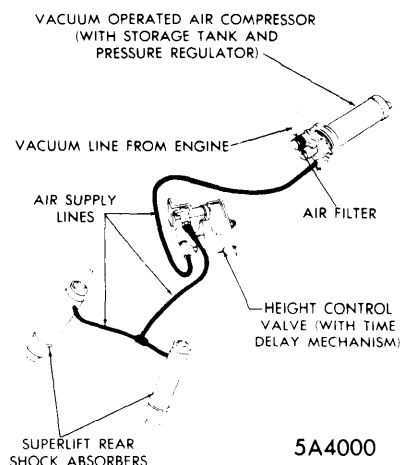

### AUTOMATIC LEVELING SYSTEM

### TROUBLE SHOOTING

**Vehicle Will Not Rise When Loaded** – External damage or breakage of components. Leaks in lines. Linkage to overtravel lever in wrong hole. Control valve setting incorrect. Faulty component in system.

**Vehicle Rises When Loaded, But Leaks Down** – Line leak. Height control valve exhaust leak. Shock absorber leak.

**Vehicle Rises Only Partially When Loaded** – Load excessive (over 500 lbs. at axle). Height control valve setting incorrect. Low supply pressure.

**Vehicle Rises Too High When Unloaded; Will Not Come Down** – Height control valve setting incorrect. External damage or breakage. Linkage to overtravel lever in wrong hole. Height control valve faulty.

**Vehicle Rises When Loaded, But Leaks Down While Driving** – Time Delay mechanism not operating properly.

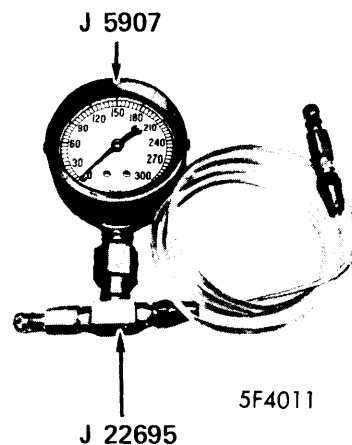

### TEST SET

### TESTING (ON VEHICLE)

**NOTE** – System test set as shown in illustration is absolutely necessary for the proper testing and trouble shooting of this system.

### QUICK CHECK OF SYSTEM

With car empty, measure distance from center of rear bumper to ground. Add weight equivalent to a two passenger load on rear of vehicle. Vehicle should begin to level in 4-22 seconds, and final position should be approximately  $\pm 1/2$ " of unloaded height. Remove weight. After 4-22 seconds, vehicle should begin to settle. Final unloaded position should be within approximately  $\pm 1/2$ " of original measurement.

### COMPRESSOR OUTPUT

1) With all accessories off, engine at normal operating temperature, and ignition off, deflate system through service valve on compressor. Remove high pressure line at regulator adapter and connect a suitable test gauge (J-22124).

2) Inflate reservoir to 70 psi through service valve and note test gauge for evidence of leak. If compressor leaks, remove it from vehicle and leak-test, as described below. If compressor is not leaking, proceed as follows: Operate engine at slow idle and note reservoir build-up for five minutes. Pressure should build to a minimum of 90 psi.

3) If compressor does not cycle, make sure all lines are open before removing compressor. If pressure build-up is too slow, compressor is faulty. If build-up is satisfactory, trouble is in the control system.

### REGULATOR

**NOTE** – The test is performed only with a known good compressor.

1) Deflate system through service valve and disconnect line at pressure regulator valve. Install test gauge on regulator valve high pressure line fitting. Inflate system through service valve to maximum available pressure.

# Automatic Level Control

## 1967-73 GENERAL MOTORS AUTOMATIC LEVEL CONTROL (Cont.)

2) If pressure is less than 140 psi, start engine to assist in pressure build-up. Test gauge should register a steady pressure between 100-130 psi. Check regulated pressure by momentarily depressing valve core on test gauge. Observe gauge reading. If pressure is now below 100 psi or in excess of 130 psi, replace regulator assembly.

### CONTROL VALVE

**NOTE** — If tests are performed in cold temperatures (15°F or less), time delay may be as much as 30 seconds.

**Exhaust (Shock Absorbers Inflated)** — 1) Disconnect control valve lever from link and hold lever down in exhaust position until shock absorbers deflate (4-22 seconds). If shock absorbers deflate, make Intake test below.

2) If shock absorbers do not deflate, remove exhaust adapter from control valve and hold lever down. Replace adapter, "O" ring, and filter if this procedure deflates shock absorbers. If above steps do not deflate shock absorbers, replace control valve.

**Intake (Reservoir at 125 psi Minimum)** — Disconnect overtravel lever from link and hold lever up in intake position until shock absorbers inflate (4-22 seconds). If shocks inflate and hold pressure, make Time Delay test below. If shocks inflate and then leak down, leak-test all components.

**Time Delay** — 1) Disconnect overtravel lever from link. Disconnect air lines at shock absorbers and intake ports. Connect test gauge to intake valve port and open air pressure (95 psi).

2) Move overtravel lever approximately one inch down from neutral position, as measured at end of lever. Hold lever down for 15-20 seconds. Quickly move lever upward two inches and note number of seconds before air starts to escape from shock absorber port. This delay should be 4-22 seconds.

3) Proceed with check to determine air exhaust time delay. Remove test gauge and plug intake port. Connect test gauge to shock absorber and open air pressure (95 psi). Move overtravel lever approximately one inch up from neutral position, as measured at end of lever. Note number of seconds before air starts to escape from exhaust port. This delay should be 4-22 seconds.

4) If either delay is not within specifications, there is either a loss of silicone fluid or valve may have lost adjustment due to wear or damage.

**Silicone Fluid Replacement** — 1) Remove control valve and clean exterior. With delay plug facing up, remove plug, drain fluid, and replace plug "O" ring. Remove cover plate retaining ring, delay cover and "O" ring from chamber.

2) Replace delay plug and tighten to 20-30 INCH lbs. Pour silicone fluid into delay piston chamber until fluid is 5/16" below top edge of body.

3) With valve body in vise, elevate delay chamber slightly and operate lever to remove any trapped air. Place a new "O" ring in delay piston bore and secure with snap ring. Position valve vertically in vise, with delay chamber down. Move overtravel lever until air is purged from chamber, then perform a Time Delay check off the vehicle.

4) If delay is still not within specifications, and if fluid level is satisfactory, replace height control valve.

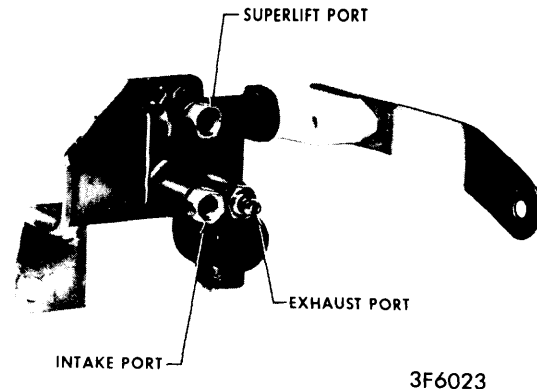

HEIGHT CONTROL VALVE (TYPICAL)

### TESTING (OFF VEHICLE)

#### LEAK TESTING

**Compressor, Reservoir, Regulator** — 1) With assembly removed from vehicle, but not disassembled, connect test set to regulator and inflate reservoir to 80-110 psi. Route a rubber hose between vacuum and vent ports.

2) Place assembly vertically in a tub of water until diaphragm is just submerged. **CAUTION** — Do not submerge assembly completely or water will enter around cover gasket. Check for air leaks. Remove hose from vacuum port and put disconnected end in water. Cover vacuum port with finger. If bubbles are present, second stage housing check valve is probably faulty.

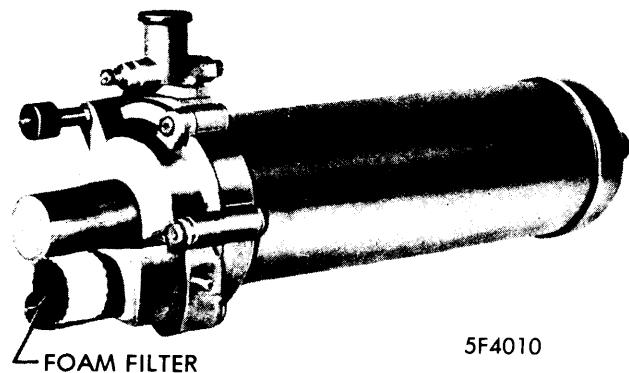

COMPRESSOR, RESERVOIR, REGULATOR ASSEMBLY

3) If compressor passes leak test but fails output test, overhaul compressor. **NOTE** — If cover gasket is accidentally submerged in water, remove cover and tilt unit so water will drain through openings at distributor valve. Move distributor valve sideways until all water is expelled. Blow dry with air and replace cover.

**Height Control Valve** — 1) Remove control valve from vehicle and clean exterior. Connect test gauge set and air pressure source to intake adapter and apply 80-110 psi.

## 1967-73 GENERAL MOTORS AUTOMATIC LEVEL CONTROL (Cont.)

2) Submerge unit in water. With overtravel lever in neutral position, no air should escape. If there are bubbles from shock absorber port, replace valve.

3) Shut off air pressure and disconnect test set, then plug intake port with Schraeder valve. Connect test set to shock absorber port and apply air pressure. With overtravel lever in neutral position, no air should escape. If air escapes from exhaust port, replace control valve. If air escapes around edge of cover plate, tighten screws or replace gasket.

4) Remove control valve from water and actuate overtravel lever to expel any water, then remove test set and air line.

**Lines & Fittings** — Disconnect overtravel lever from link, hold lever up in intake position, then release. Leak-test all connections with soapy water.

**Shock Absorbers** — Remove shock absorber from vehicle, inflate individually to 50-60 psi and submerge in water. If air leaks are present, replace unit.

### REGULATOR

See *Testing (On Vehicle)*.

## ADJUSTMENT

### TRIM ADJUSTMENT

1) **NOTE** — Make adjustment with full fuel tank, or equivalent weight. Raise vehicle and support axle. Remove shock absorber line at control valve. Connect a fill valve to air supply line. Inflate shock absorbers to 8-15 psi. Jounce vehicle to equalize suspension.

2) Connect test gauge to shock absorber adapter on control valve and attach an air pressure source (80-110 psi) to gauge. Loosen height control valve lever adjusting nut. Hold overtravel lever in exhaust position until air escapes from exhaust port.

3) Slowly move overtravel lever toward neutral position and point a minimum air bleed through exhaust port. Tighten nut. A slight continuous air bleed should be noticeable. Lower vehicle to floor and inflate system through service valve on compressor.

## REMOVAL & INSTALLATION

### HEIGHT CONTROL VALVE

**Removal** — Deflate system through service valve. Disconnect air lines at leveling valve intake and shock absorber ports. Disconnect link from overtravel lever by removing nut. Remove screws securing leveling valve to frame and remove valve.

**Installation** — Reverse removal procedure and inflate system to 140 psi through service valve.

### COMPRESSOR, RESERVOIR, REGULATOR

**Removal** — Deflate system. Remove air intake and vacuum hoses from compressor. Remove high pressure line from regulator. Remove screws securing compressor to wheelhouse and remove compressor assembly.

**Installation** — To install, reverse removal procedure and inflate system to 140 psi through service valve.

## OVERHAUL

### COMPRESSOR ASSEMBLY

1) Remove flexible mounts, adapters, cover, and gaskets from first stage housing. Remove regulator and "O" ring from second stage housing. Discard ring.

2) Separate first and second stage housing assemblies. Slide second stage (small diameter) housing from piston. Disconnect arm tension spring from swivel arm. Remove arm pivot screw and actuating arm. Slide piston assembly out of first stage housing. **NOTE** — Do not lubricate unit as it is designed to operate dry. Always hold bolts stationary and remove nuts during disassembly. Do not turn bolt heads. Short bolts have a second (hidden) nut between reservoir flange and second stage housing.

### DIAPHRAGM

1) If diaphragm is loose or has holes, replace it as follows: Remove and discard retainer. Remove diaphragm plate, diaphragm, second diaphragm plate, and corprene washer from piston.

2) Install new corprene washer, plate, diaphragm (with outer lip toward second stage side), and first diaphragm plate. Plates should be installed with lip on both plates facing outward from diaphragm. Use a 13/16" deep socket to press diaphragm retainer into position (see illustration).

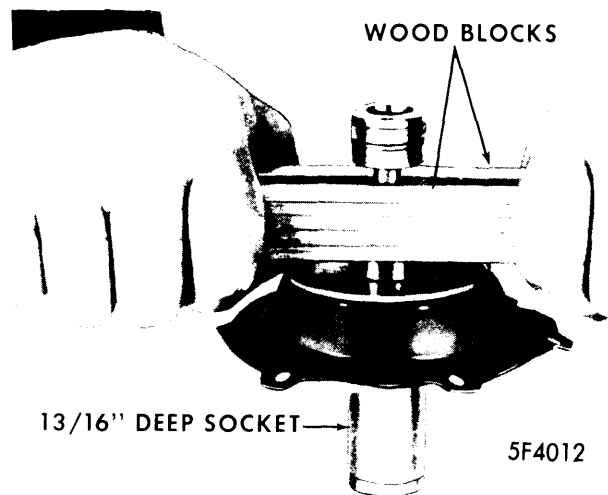

### INSTALLING DIAPHRAGM RETAINER

### FIRST STAGE HOUSING

**NOTE** — Operate distributor valve with finger. Valve tension spring should press against distributor valve and hold it against either stop. If valve operation is not free, new parts should be installed during reassembly. If action is free and positive, old parts may be reused.

1) Remove screw, washer, distributor arm assembly, washer, distributor valve bushing, both arm assembly stop bushings, and both distributor stop bushings. Remove distributor valve, making sure the valve tension spring is not distorted. Remove tension spring from bowl cover boss, then remove intake valve retaining spring, intake valve, and washer. Remove rocker and swivel arms, if required, by removing pin.

## 1967-73 GENERAL MOTORS AUTOMATIC LEVEL CONTROL (Cont.)

2) Install rocker arm bushings, rocker arm, and swivel arm in first stage housing. Install rocker arm retaining pin (small end first). Install washer on intake valve and position in housing with intake valve retaining spring.

3) Install longer leg of valve tension spring into boss on first stage housing, then install distributor valve. Install both distributor valve stop bushings and both arm assembly stop bushings. Install distributor arm assembly and washer and tighten screw to 12 INCH lbs. *NOTE* — Do not install remaining parts, as rocker arm must be free to allow entry of piston into first stage housing.

**CHECK VALVE (SECOND STAGE PISTON)**

Pry out expansion plug retainer on second stage piston and remove spring and check valve. Put a small amount of solvent into bore and dry with compressed air. Check valve seat should be smooth and clean. Install new check valve and spring, then install new expansion plug retainer and tap into position (retainer must bottom).

**COMPONENT REASSEMBLY**

1) Slide piston assembly into first stage (large diameter) housing, install actuating arm and attach to first stage housing with arm pivot screw. Tighten screw to 12 INCH lbs. Connect arm tension spring to swivel arm, then rotate piston in housing to align elongated hole in diaphragm, with vent port in housing.

2) Install through-bolts retaining first and second stage housings together. Position nuts in counterbores of second stage housing and tighten to 28 INCH lbs. Tighten reservoir retaining bolts to 28 INCH lbs. (bolt heads should be positioned against reservoir; do not install cover retaining bolts).

3) Install "O" ring on regulator. Position regulator on housing and tighten screws to 35 INCH lbs. *NOTE* — Service valve should be on same side as first stage housing. Install cover and gasket. Tighten cover screws to 35 INCH lbs. Install adapters and flexible mounts. Install compressor and test compressor output.