

1965-73 CORVETTE REAR

Corvette (1965-73)

DESCRIPTION

Leaf spring type, with spring mounted transversely on a fixed differential carrier. Each wheel is mounted by a three-link independent suspension composed of a wheel drive shaft, camber control strut rod, and trailing wheel spindle support arm.

ADJUSTMENT

Camber & Toe-In — See *Wheel Alignment Specifications & Adjustment* in **WHEEL ALIGNMENT** Section.

Wheel Bearings — See *Wheel Bearing Adjustment* in **WHEEL ALIGNMENT** Section. Also see *General Motors Integral Housing* in **REAR AXLE** Section.

WHEEL BEARING ENDPLAY

Spindle bearings should have endplay of .001-.008". If adjustment is not within limits, adjust as outlined: See *Outer Bearing Replacement* under **SPINDLE & BEARING**.

Checking — Raise vehicle on hoist. Disconnect outboard end of axle drive shaft from wheel spindle flange. Mark camber cam position to bracket. Loosen and turn camber bolt until strut rod forces torque control arm outward. Position loose end of axle drive shaft out of way. Remove wheel and tire assembly. Mount suitable dial indicator (J-8001) on torque control arm adjacent surface and rest pointer on flange or spindle end. Move brake disc in and out and note dial gauge reading.

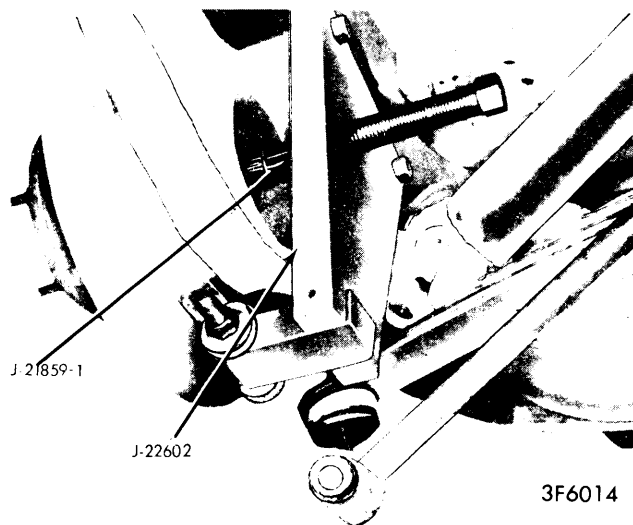

SPINDLE REMOVAL

SPINDLE & BEARING

Spindle Removal — Apply parking brake, to prevent spindle from turning, and remove cotter pin and nut. Release parking brake and remove drive spindle flange from splined end of spindle. Remove brake caliper and brake disc: see **DELCO-MORAINÉ FOUR PISTON DISC** in Section 8. Install suitable thread protector (J-21859-1) over spindle threads and remove drive spindle from support, using suitable removal tool (J-22602). **CAUTION** — Ensure puller plate is positioned as shown in illustration. Outer bearing will remain on spindle; in-

ner bearing, tubular spacer, endplay adjustment shim, and both outer races will remain in spindle support. Remove bearing, spacer, and shim (record shim size for replacement).

Outer Bearing Replacement — Mount spindle, hub, and disc assembly in padded vise, mark position of hub to flange, and drill out attaching rivets. Unseat and remove bearing, using suitable tool (J-8331). See illustration. Remove outer seal. Inspect and replace as necessary. Pack bearings with suitable grease and position on spindle. Press bearing into place. See illustration. If new bearings are being installed, remove races from support and install new parts. If bearing endplay is within limits, as previously described, use original size adjusting shims for replacement. If greater than .008", reduce shim thickness; if no endplay is found, add .003" to original shim. Install tubular spacer and suitable shim onto spindle.

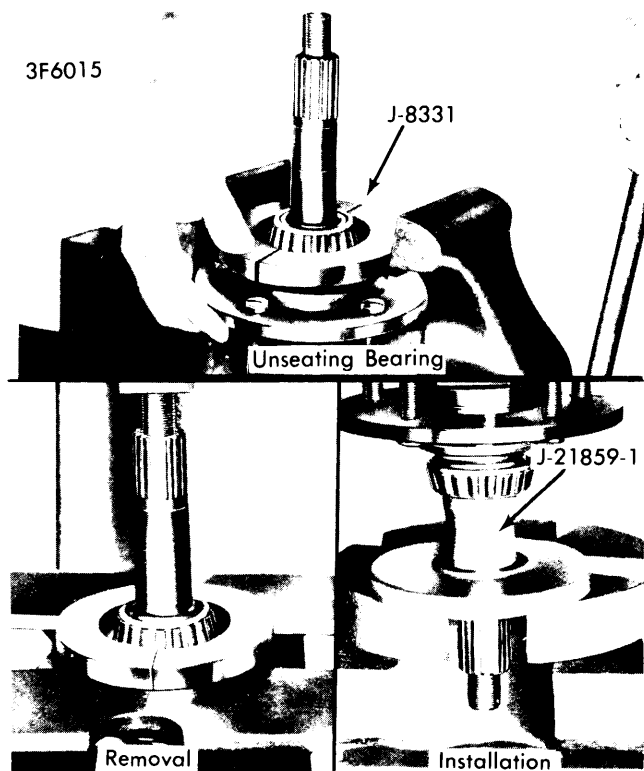

OUTER BEARING REMOVAL & INSTALLATION

Spindle Installation — Position spindle into support and ensure oil seal, outer bearing, spacer, and shim are in correct position. Position suitable tool (J-4731) over spindle and against inner race. Place washer and nut on spindle and tighten nut until inner bearing assembly is forced on spindle. Remove tool and nut. Seat outer oil seal in bore. Position drive flange over spindle, install washer and new nut and torque to specifications. Recheck endplay. Install caliper assembly, drive shaft, and wheel. **NOTE** — It is not necessary to replace rivets in flange. Adjust camber. Torque all components to specifications.

1965-73 CORVETTE REAR (Cont.)

SPINDLE SUPPORT

Removal — Remove spindle, as previously described. Detach parking brake cable from actuating lever. Unbolt spindle support from torque control arm, withdraw brake backing plate, and position out of way. Disconnect shock absorber lower mounting. **NOTE** — *It is advisable to support spring outer end before disconnecting shock absorber.* Remove nut from strut rod mounting shaft. Pull shaft from support and strut rod. Separate support from torque control arm.

Installation — Position support over torque arm bolts, with strut rod fork pointing toward center of vehicle and downward. Position backing plate and torque attaching nuts to specifications. Install strut rod and shock absorber mounting shaft onto support arm. Install shock absorber. Torque to specifications. Connect parking brake cable to actuating lever. Reinstall drive spindle assembly.

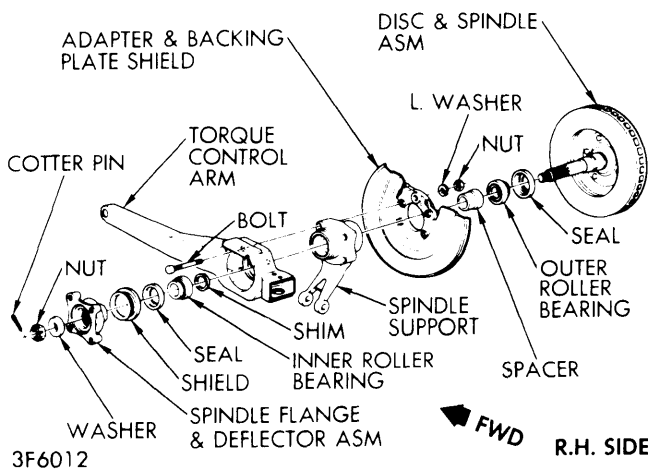

SPINDLE ASSEMBLY

REMOVAL & INSTALLATION

STRUT ROD & BUSHINGS

Removal — With vehicle raised, disconnect shock absorber lower eye from strut rod shaft, remove strut rod shaft nut, and withdraw shaft by pulling toward front of vehicle. **NOTE** — *Mark relative position of camber adjusting cam and bracket, for proper reassembly.* Loosen camber bolt and remove four bolts securing strut rod bracket to carrier and lower bracket. Remove cam bolt nut and cam-and-bolt assembly, then pull strut down out of bracket and remove bushing caps.

Bushing Removal — With strut rod bushing centered over suitable removal tool (J-7877-2), support strut rod horizontally and press bushing from rod, using suitable tools (J-7877-1 & J-7079-2).

Bushing Installation — Center strut rod end over suitable tool (J-7877-2) and press bushing to bottom, on strut rod, using suitable tool (J-7877-3).

Installation — With bushing caps over inboard bushing, slide rod into bracket, install cam and bolt assembly, and adjust cam to line up with mark on bracket. Tighten, but do not torque, nut. Raise bracket and assemble to carrier lower mounting surface. Torque bolts to specifications. Raise outboard end of strut rod into spindle support fork and insert strut rod shaft into fork: align flat on shaft with corresponding flat in spindle fork. Place shock absorber lower eye and bushing over strut shaft. Tighten to specifications. Lower vehicle to floor and torque camber nut and strut rod shaft nut to specifications. Check wheel camber.

SPRING

Removal — Raise vehicle on hoist, allowing axle to hang. Remove wheel and tire assemblies. Install "C" clamp on spring approximately 9" from one end. Tighten securely. Place adjustable lifting device under spring, with lifting pad of jack inboard of link bolt, near "C" clamp. Insert a wood block between clamp and jack pad. See illustration. Raise jack until load is released from link. Remove link nut and cushion. Carefully lower jack until spring tension is released. Repeat procedure on other side. Remove four bolts securing spring center clamp plate. Slide spring from vehicle.

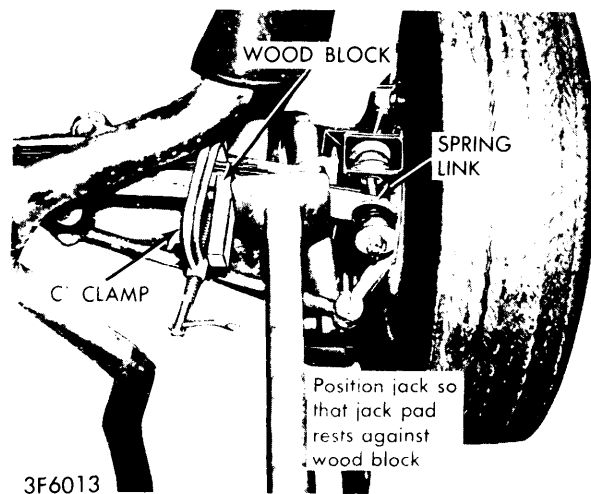

SPRING REMOVAL

Spring Liners and/or Cushion Retainers — Clamp spring center section in vise and remove center bolt. Release vise and separate leaves. Replace worn or damaged liners. Replace main leaf spring cushion by chiseling over flared portion until retainers may be knocked out of leaf. Position new retainers and flare over with hammer. Insert drift into center bolt hole, to align leaves. Install center bolt and tighten securely.

Installation — Place spring on carrier cover mounting, position center clamp plate and bolts, and torque to specification. Reinstall "C" clamp, wood block, and jack, as used during removal. Raise spring end until nearly flat, align with torque arm, and install new attaching parts. Repeat procedure on other side. When lowering jack, ensure cushions remain in position.

1965-73 CORVETTE REAR (Cont.)

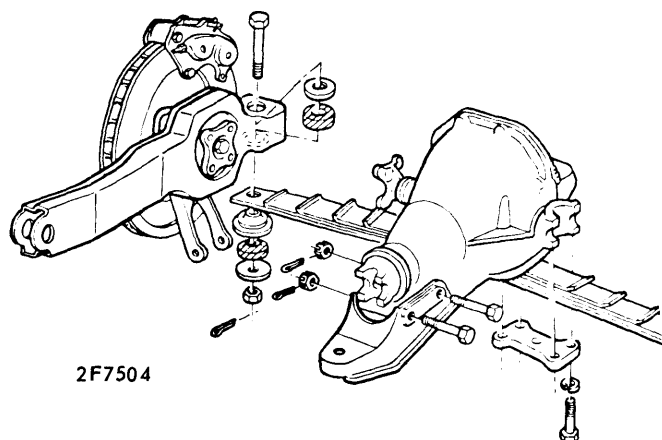

CORVETTE REAR SPRING INSTALLATION

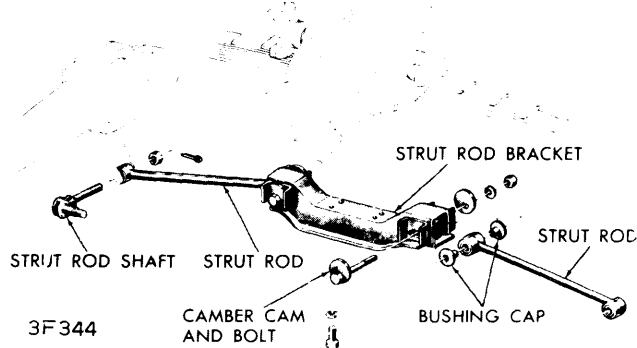

CORVETTE STRUT ROD ASSEMBLIES

TORQUE CONTROL ARM & BUSHINGS

Removal — Disconnect spring on side from which torque arm is to be removed. Detach lower shock mounting, unbolt and remove strut rod. Swing rod down and remove four bolts securing axle drive shaft to spindle flange. Disconnect drive shaft. *NOTE* — It may be necessary to force torque arm outboard to provide clearance for dropping drive shaft. Disconnect parking brake cable. Remove brake hose from torque arm. Loosen torque arm pivot bolt and remove toe-in shims. Tape shims together and identify for reinstallation. Withdraw pivot bolt and pull torque arm out of frame.

Bushing Removal — With torque arm off vehicle, drill out flared end of bushing retainer, remove retainer plate and tap retainer out of bushing. Remove bushings (spread with tool and tap out of arm). *NOTE* — If bushing diameters are severely rusted in torque arm, clamp arm in "C" clamp to prevent arm from spreading, during removal.

Bushing Installation — Hand start bushings in arm, then press into place, using suitable tool (J-7055-1). With special plate over flared portion of new bushing retainer, insert retainer into bushing. Place fabricated back-up plate on flared end of bushing retainer and assemble suitable tool (J-8111-23) to plate with two 1/2 x 5" bolts. Ensure threaded hole of tool is centered over unflared end of bushing retainer and that chamfered retainer plate is centered over retainer tube. Lightly oil pointed end of special screw (J-8880-5) and thread into suitable flaring tool (J-8111-23) until flaring is complete.

Installation — With torque arm in frame opening, insert pivot bolt and assemble. Place toe-in shims in original position on both sides of torque arm, then tighten pivot bolt (do not torque). Raise axle drive shaft into position and install to drive flange, then torque bolts to specifications. Position strut rod and insert rod shaft aligning flat of shaft with flat in spindle support fork. Torque to specifications. Reattach and torque lower shock absorber mounting. Connect spring. Install wheel, lower vehicle, and tighten torque arm.

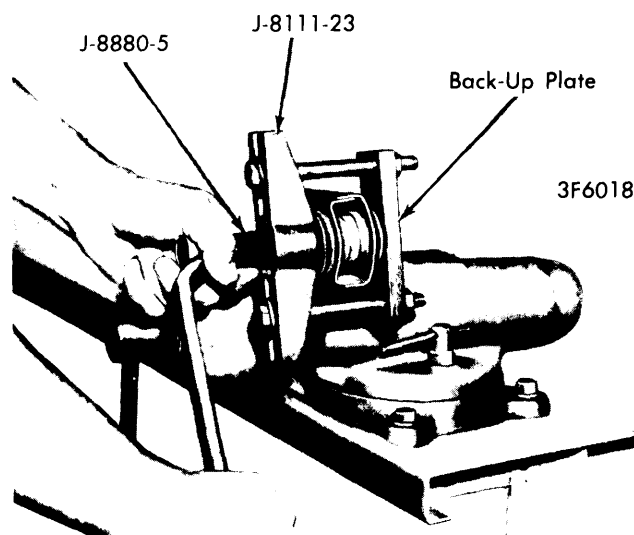

FLARING BUSHING RETAINER

SUSPENSION CROSSMEMBER & ISOLATION MOUNT

Removal — Disconnect and remove spring, as previously outlined. Remove differential carrier and cover assembly: see *General Motors Integral Housing in REAR AXLE Section*. Support crossmember, remove securing bolts, and lower crossmember.

Isolation Mount Removal — With suspension crossmember off car, remove bolts securing carrier cover to crossmember, and bend back isolation mount tabs. Place crossmember on a suitable support and press mount out of arm, using suitable size piece of pipe, on outer shell or inner insert.

Isolation Mount Installation — Position mount on crossmember, compress outer sleeve and press mount into place until fully seated. Bend over locking tabs.

Installation — Raise crossmember into position and install mounting bolts. Torque to specifications. Install differential carrier and cover assembly. Reposition spring. Mount wheel and lower vehicle.

STABILIZER SHAFT

Removal — Raise and support vehicle at frame side rail. Disconnect stabilizer at both torque arms. Remove stabilizer shaft brackets from frame and withdraw assembly from vehicle.

Installation — Position new bushings on shaft, loosely install shaft on torque arms and at frame brackets. *NOTE* — Install flange of bushing on wheel side of link. Align shaft and torque bolts to specifications.

Front & Rear Suspension

1965-73 CORVETTE REAR (Cont.)

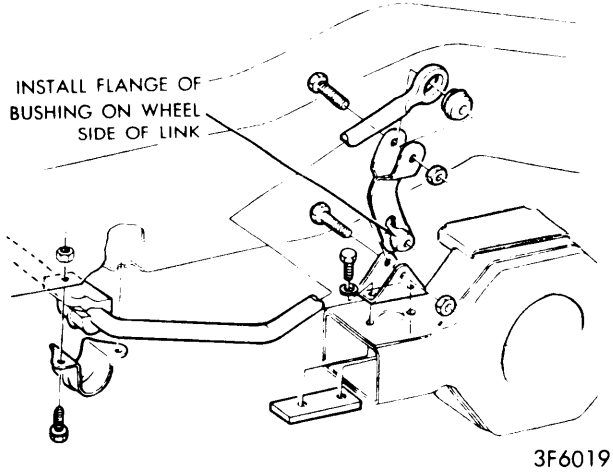

STABILIZER SHAFT INSTALLATION

TIGHTENING SPECIFICATIONS	
Application	Ft. Lbs.
Strut Rod Bracket-to-Carrier	
1965-67	15-22
1968-73	45
Camber Cam	65
Strut Rod Shaft-to-Spindle Support Fork	
1965-69	80
1970-73	75
Leaf Spring Retainer.....	70
"U" Joint Companion Flange	15
Crossmember-to-Carrier	
1965-69	25-35
1970-73	60
Lower Control Arm Front Bushing.....	50
Axle Drive Shaft-to-Spindle	75
Axle Drive Shaft-to-Yoke	15
Stabilizer Link Bushing Bolts.....	25
Drive Spindle Support-to-Torque Arm.....	30
Torque Arm Pivot	50
Shock Absorber Mounting	
Upper.....	50
Lower	35