

# Steering Columns

## JEEP

### All Models

### DESCRIPTION

All models use a collapsible column which is equipped with an anti-theft locking feature. All models are available with an optional Adjust-O-Tilt steering column. The Adjust-O-Tilt steering column is also equipped with the energy-absorbing and anti-theft features.

### REMOVAL & INSTALLATION

**CAUTION:** When servicing the steering column, use **ONLY** specified attaching screws and bolts. Screws or bolts longer than specified could damage collapsible feature of the steering column. Attaching nuts and bolts for the column mounting bracket must be tightened to specifications to allow bracket to break away under impact.

#### STEERING COLUMN

##### Removal (All Models)

1) Disconnect battery ground cable. If equipped with automatic transmission, disconnect transmission shift rod at steering column shift lever.

2) On Cherokee and Wagoneer with automatic transmission and power brakes, it will be necessary to shift transmission to "1" detent position to gain access to shift rod retaining clip at shift lever.

3) Remove upper steering shaft to intermediate shaft "U" joint pinch bolt. Do not attempt to separate upper steering shaft and intermediate shaft at this time.

4) On Cherokee and Wagoneer models with air conditioning, remove left duct extension. On all models, remove steering column to instrument panel bezel. On Cherokee, Wagoneer and truck models, bezel screws are located behind lower bezel half.

5) Remove bolts securing steering column mounting bracket to instrument panel. Remove bolts securing mounting bracket to steering column and remove bracket.

**CAUTION:** Extra care must be used with bracket to prevent damage to breakaway capsules.

6) Remove upper and lower toe-plates. Disconnect wiring harness at ignition switch, removing black connector first.

7) If equipped with Cruise Command, disconnect electrical connector. Separate steering shaft from intermediate "U" joint and remove steering column assembly.

**CAUTION:** After steering column is removed treat with care, shock may cause damage.

##### Installation (All Models)

1) Place steering column in vehicle. Connect upper steering shaft to intermediate shaft "U" joint. Install "U" joint pinch bolt and tighten.

2) If equipped with Cruise Command, connect electrical connector. Connect ignition switch connectors, connecting white connector first.

3) Install upper and lower toe plates. Install bolts but do not tighten. Install mounting bracket on

steering column. Align column with instrument panel. Install bracket to instrument panel bolts but do not tighten.

4) Pull up on column and tighten bolts. Make sure bolts are tightened while pulling up on column. Tighten toe plate bolts.

5) Install both halves of instrument panel bezel. Install left air conditioning duct extension (if removed). Connect transmission shift rod to shift lever.

6) Connect battery ground cable. Check automatic transmission shift linkage operation and adjust as necessary. Check for correct operation of all electrical components.

### OVERHAUL

#### STEERING COLUMNS W/OUT TILT WHEEL

##### Disassembly (Man. Trans.)

1) Remove steering column from vehicle as previously outlined. Remove mount bracket from column. Attach a holding fixture (J-23074) to mount bolt holes. Secure column in a vise by clamping on holding fixture.

2) Remove steering wheel. Using two screwdrivers, pry anti-theft cover off lock plate. Compress lock plate using a compressor tool. If steering shaft nut has metric threads, it will have an identifying groove in the steering wheel locating splines.

3) American threaded nuts do not have this groove. For metric threads, use tool J-23653-4. For American threads, use tool J-23653. Remove snap ring from steering shaft.

Fig. 1: Removing Lock Plate Snap Ring

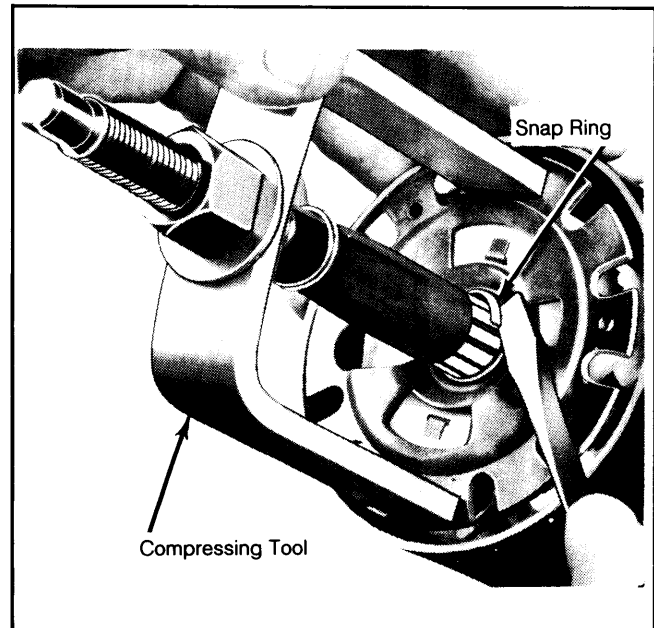

4) Remove compressor tool. Remove snap ring and discard. Remove lock plate, directional signal cancelling cam, upper bearing preload spring, and thrust washer from steering shaft.

**CAUTION:** After snap ring is removed from shaft, the steering shaft is free in column. Do not allow shaft to fall out end of column.

# Steering Columns

## JEEP (Cont.)

Fig. 2: Exploded View of Steering Column

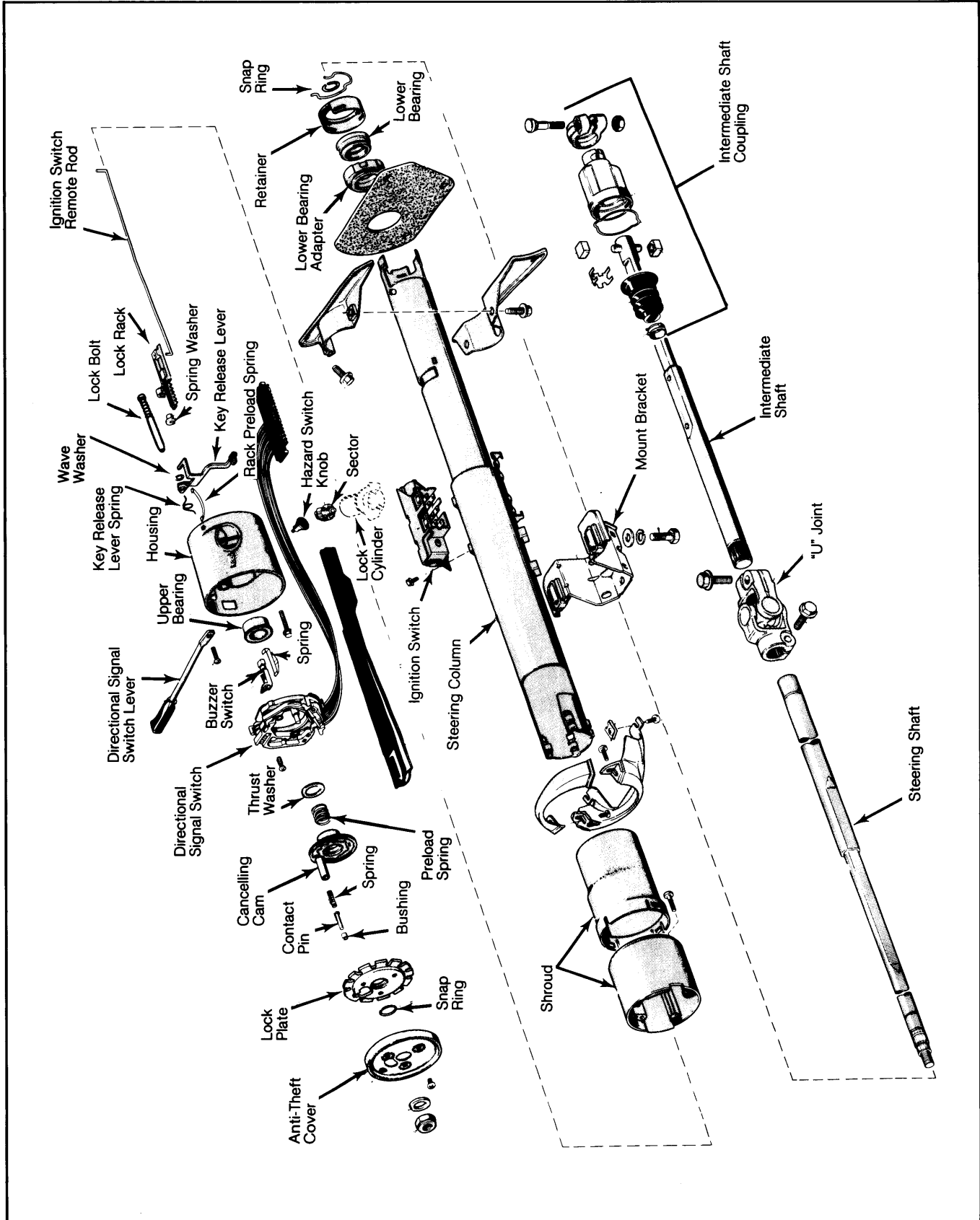

Manual transmission models without tilt wheel option are shown.

# Steering Columns

## JEEP (Cont.)

5) Remove steering shaft from lower end of column. Remove hazard warning switch knob by pressing inward and unscrewing. On vehicles without Cruise Command, remove directional signal switch lever.

6) On vehicles with Cruise Command, disconnect two of four wires at switch connector. Fold wires back along harness. Tape wires and a length of string to harness to aid removal.

7) Remove directional switch connector from bracket at lower end of column. Separate switch connector by lifting plastic lock tab on connector. Wrap tape around connector and harness to prevent snagging during removal.

8) Remove directional signal switch screws. Remove switch and harness by pulling straight up and out of column. On vehicles with Cruise Command, remove directional switch lever. Remove Cruise Command switch (in directional signal switch lever) and harness using string taped to harness.

9) Turn ignition switch 2 detent positions beyond "OFF" position. Using a thin bladed screwdriver, compress lock cylinder retaining tab and remove cylinder from column. The retaining tab is reached through slot next to directional switch mounting boss.

**NOTE:** If retaining tab is not visible through slot, remove any casting flash that may be in slot.

10) Remove ignition switch from lower end of column. Remove screws securing directional signal switch housing and shroud to column. Remove housing and shroud. Disconnect ignition switch remote rod from lock rack.

11) Remove screws securing shroud to housing and remove shroud. Remove wave washer from key-release lever pivot. Remove key release lever and spring. Remove lock rack and bolt assembly. Remove rack preload spring. See Fig. 3.

**Fig. 3: Wave Washer Removal for Manual Transmission Models**

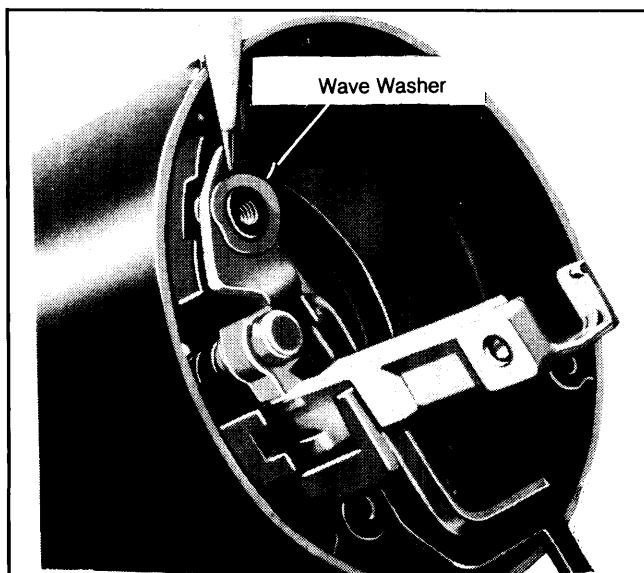

12) Using a punch, push on block tooth of sector and push sector through lock cylinder hole. Remove lower bearing snap ring from retainer. Remove retainer, bearing and adapter.

### Reassembly

1) Coat all friction surfaces with multi-purpose grease before reassembly. Position sector on sector shaft. Insert sector through lock cylinder hole. Use a blunt punch to push sector into place. Make sure sector turns freely after installation.

2) Install rack preload spring. Make sure bowed side of preload spring is against lock rack. Assemble lock rack and lock spring as shown in Fig. 4.

**Fig. 4: Assembly Lock Bolt and Lock Rack**

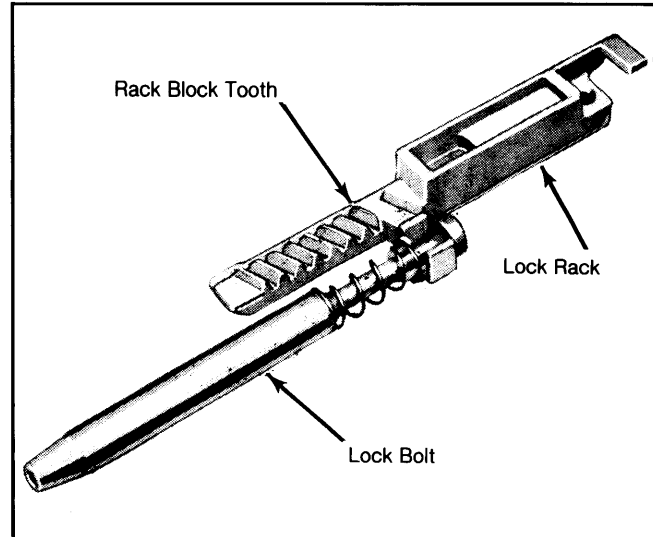

3) Install assembled lock bolt and lock rack in housing. Make sure block tooth of lock rack is mated with block tooth of sector. See Fig. 5.

**Fig. 5: Installing Lock Bolt and Lock Rack**

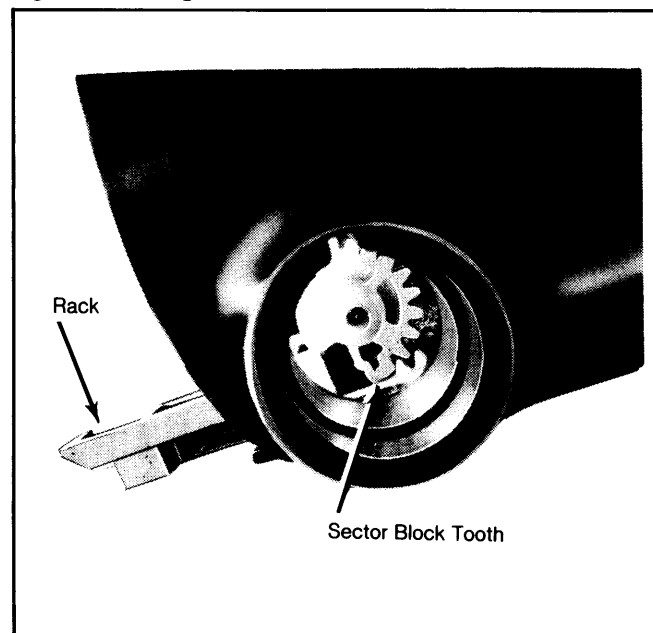

4) Place key release lever return spring over post in housing. Place release lever finger in lock rack slot. Position hole in lever over threaded hole in housing post. Make sure inner end of spring contacts release lever. See Fig. 6.

## JEEP (Cont.)

**Fig. 6: Installing Release Lever and Spring on Manual Transmission Models**

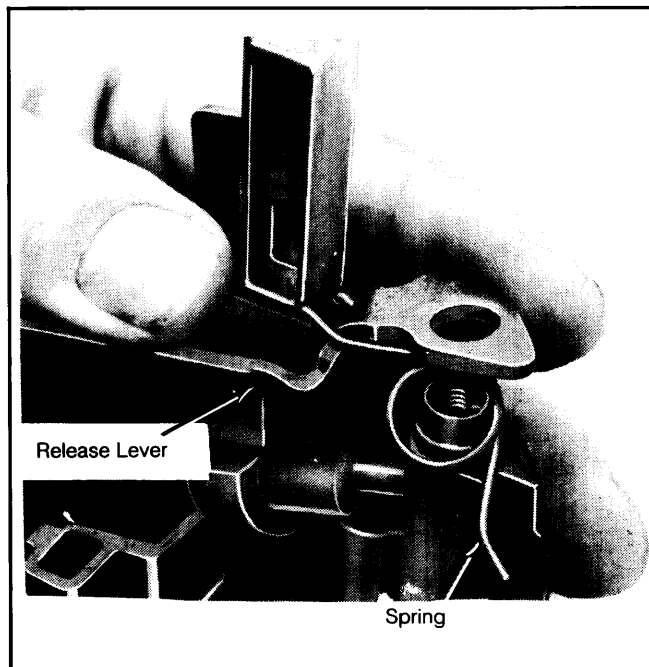

5) Raise lever slightly and place end of lever spring between lever and housing boss. Coat wave washer with multi-purpose grease. Place wave washer on post over release lever.

6) Place shroud on directional signal switch housing. Install and tighten retaining screws. Make sure release lever wave washer is not dislodged when shroud is installed. Install remote rod on lock rack with short end of rod in rack.

7) Place assembled housing and shroud on column. Install and tighten retaining screws. Install lock cylinder to housing. Insert key in lock cylinder. Hold cylinder sleeve and rotate key clockwise until key stops. This will retract actuator.

8) Place lock cylinder in housing bore making sure cylinder tab is aligned with keyway in housing. Push cylinder inward until it bottoms. Rotate key counterclockwise until drive section of cylinder mates with sector. Push cylinder in fully until tab engages in housing groove.

9) Now turn cylinder clockwise to stop, then counterclockwise to stop at "OFF-UNLOCK" position. Place ignition switch on jacket. Move switch to extreme left position ("ACC"). Now move slider 2 positions to right ("OFF-UNLOCK"). Insert remote rod into switch slider hole. Place switch on column. Install and tighten retaining screws.

10) Install lower bearing, bearing adapter, retainer and snap ring in lower end of column. Insert steering shaft in column through lower end. Bend directional signal switch wires against connector. Feed connector and harness through housing and shroud. Align switch in housing. Install and tighten retaining screws.

11) On vehicles without Cruise Command, install directional signal switch lever. On vehicles with Cruise Command, install lever and switch assembly. Use string taped to harness during disassembly to help feed wires into housing. Remove string and tape. Connect wires to switch terminal and install lever.

12) Install thrust washer, upper bearing preload spring, and cancelling cam on steering shaft. Position cancelling cam as shown. See Fig. 7. Place directional signal switch in neutral position and install hazard warning switch knob.

**Fig. 7: Directional Signal Switch Cancelling Cam Position**

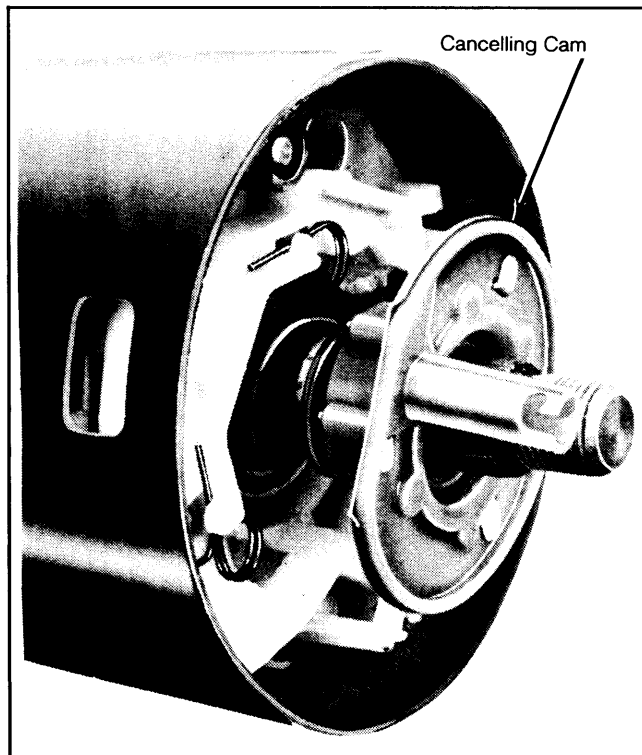

13) Position lock plate on steering shaft. Place new snap ring on sleeve of compressor tool (J-23653 for American threads, J-23653-4 for metric threads). Thread tool sleeve onto end of steering shaft. Compress lock plate with tool and install snap ring in groove in steering shaft. Install anti-theft cover.

14) Remove support tool from steering column. Install mounting bracket and tighten bolts to specification. Connect directional signal switch wire connector to column bracket. Install steering wheel. Install column in vehicle as previously outlined.

### Disassembly (Auto. Trans.)

1) Remove steering column from vehicle as previously outlined. Remove mounting bracket from column. Attach a holding fixture (J-23074) to mount bolt holes. Secure column in a vise by clamping holding fixture.

2) Remove steering wheel. Using two screwdrivers, pry anti-theft cover off lock plate. Compress lock plate using compressor tool (J-23653 for American threaded steering shaft nut, J-23653-4 for metric nut). Remove snap ring from steering shaft.

3) Remove compressor tool. Remove snap ring and discard. Remove lock plate, directional signal cancelling cam, upper bearing preload spring, and thrust washer from steering shaft.

**CAUTION: After snap ring is removed from steering shaft, shaft is free in column. Do not allow shaft to fall out end of column.**

# Steering Columns

## JEEP (Cont.)

Fig. 8: Exploded View of Steering Column

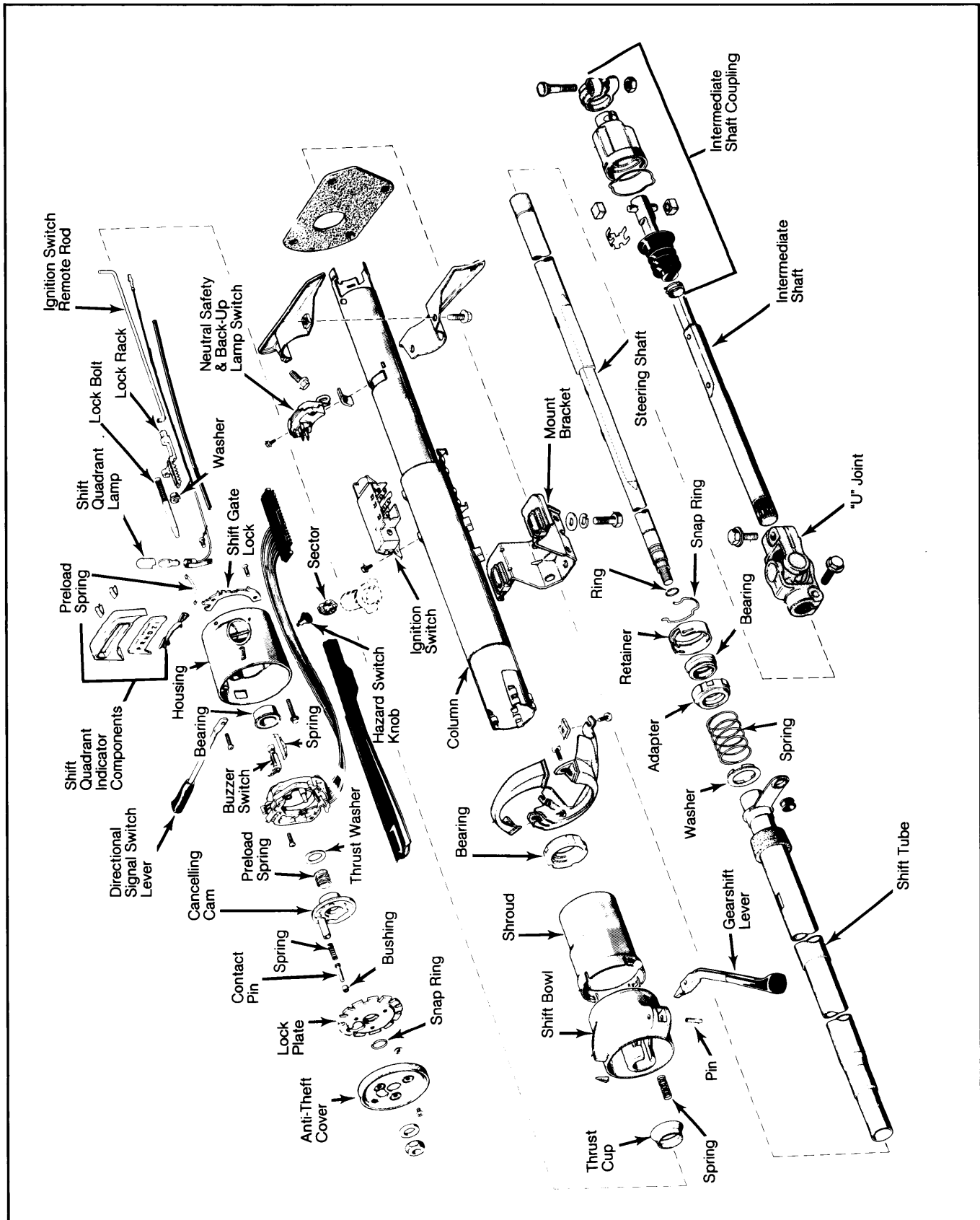

Automatic transmission models without TILT WHEEL option are shown

## JEEP (Cont.)

4) Remove steering shaft from lower end of column. Remove hazard warning switch knob by pressing inward and unscrewing. On vehicles without Cruise Command, remove directional signal switch lever.

5) On vehicles with Cruise Command, disconnect two of four wires at switch connector. Fold wires back along harness. Tape wires and a length of string to harness to aid removal.

6) Place gearshift lever in "P". Drive out gearshift lever pin using a small drift punch. Remove gearshift lever. Disconnect directional signal switch connector from bracket at lower end of column.

7) Using stiff wire, compress lock tab retaining shift light wire in connector and remove wire from connector. Remove lower bracket and plastic wiring harness connector. Wrap tape around directional switch connector and wiring harness to prevent snagging during removal.

8) Pull switch straight up and out of column to remove. On vehicles with Cruise Command, remove directional signal switch lever. Remove Cruise Command switch (in directional signal switch lever) and harness using string taped to harness.

9) Place lock cylinder in "LOCK" position. Compress cylinder retaining tab and remove lock cylinder. The retaining tab is reached through slot next to directional signal boss in housing.

**NOTE:** If retaining tab is not visible through slot, remove any casting flash that may be in slot.

10) Remove ignition switch from lower end of column. Remove screws securing upper housing to column and remove housing. The ignition switch remote rod and shift quadrant light wire will be removed with upper housing.

11) Remove thrust cup from upper housing. Remove lock bolt and rack. Remove rack and preload spring. Using a blunt punch, remove sector from sector shaft. Note position of sector for reassembly. Remove sector through lock cylinder hole.

12) Remove shift gate lock from upper housing. Inspect shift gate lock detents for wear and replace as necessary. Remove shift quadrant by prying out two clips with a small punch. Remove quadrant light cover and socket assembly.

13) Remove shift bowl from column. Remove lower nylon bowl bearing from upper end of column. Remove lower bearing retainer, retaining ring, preload spring and nylon washer. Remove shift tube and nylon bearing from tube.

### Reassembly (Auto. Trans.)

1) Apply multi-purpose grease to all friction surfaces. Install shift tube. Install nylon thrust washer in lower end of shift tube, making sure flat side of washer faces upper end of tube.

2) Install preload spring and lower bearing making sure bearing metal face is toward retainer. Install retainer and retainer ring.

3) Install lower nylon bearing in upper end of column. Make sure smaller inside diameter faces toward lower end of tube and bearing notches engage three locator crimps in column.

4) Align shift bowl with shift tube spline and install bowl. Install rack preload spring in upper housing. Place large end of sector on sector shaft. Place sector into place using a blunt punch.

5) Install shift gate lock and retaining screws. Tighten screws. Install shift quadrant lamp and cover. Install quadrant indicator by pressing retainer clips into place with flat side toward bowl.

6) Assemble lock bolt and lock rack. See Fig. 4. Install lock bolt and lock rack in shift bowl. See Fig. 9. Make sure block tooth of lock rack engages block tooth of sector. See Fig. 5.

**Fig. 9: Installing Lock Rack and Bolt into Shift Bowl**

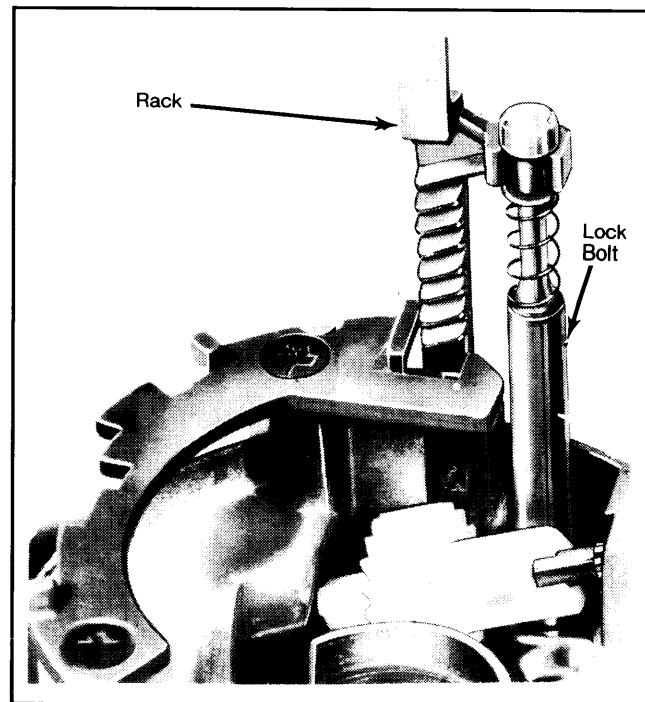

7) Install nylon thrust cup in upper housing, making sure flared end of cup faces outward. Rotate shift bowl as far as possible counterclockwise and install upper housing. Tighten screws.

8) Guide shift quadrant lamp wire and remote lock rod into position between shift bowl and column. Install directional signal switch and harness in column. Remove tape from harness and connector. Place harness in plastic protector. Install and tighten switch retaining screws.

**NOTE:** Make sure switch actuating lever pivot is correctly aligned and seated in upper housing boss.

9) On vehicles without Cruise Command, install directional signal switch lever. On vehicles with Cruise Command, install directional switch lever and Cruise Command switch using string taped to harness. Remove string and tape. Connect wires to terminals.

10) Install steering shaft from lower end of column. Install thrust washer, upper bearing preload spring and cancelling cam on steering shaft. Install lock plate, making sure lock plate splines are aligned with steering shaft splines. Make sure cancelling cam shaft protrudes through lock plate opening.

11) Install a new steering shaft snap ring on lock plate compressor tool (J-23653 for American threaded steering shaft nut, J-23653-4 for metric threaded nut). Thread tool onto steering shaft. Compress lock plate

# Steering Columns

## JEEP (Cont.)

with tool. Install snap ring in groove in steering shaft. Remove compressor tool.

12) Install anti-theft cover. Install steering wheel. Install gearshift lever. Install lock cylinder in cover. Install ignition switch on column. Place shaft bowl in any position but "P". Rotate bowl until lock rack bottoms against lower surface of bowl.

13) Move ignition switch slider to left toward "ACC" position. Move slide two positions to right toward "OFF-UNLOCK" position. Insert remote rod into slider hole. Attach ignition switch to steering column. Move switch out of "OFF-UNLOCK" position. Install column in vehicle as previously outlined.

### TILT WHEEL

#### Disassembly (Cherokee, Truck & Wagoneer)

1) Remove steering column from vehicle as previously outlined. Remove mount bracket from column. Attach a holding fixture (J-23074) to mount bolt holes. Secure column in a vise by clamping on holding fixture.

2) Remove steering wheel. Using two screwdrivers, pry anti-theft cover off lock plate. Compress lock plate using tool (J-23653 for American threaded steering shaft nut, J-23653-4 for metric threaded nut). Remove snap ring from groove in steering shaft. See Fig. 15.

3) Remove compressor tool. Remove snap ring and discard. Remove lock plate, directional signal cancelling cam, upper bearing preload spring thrust washer, spring seat and bearing race from steering shaft. Remove gearshift lever retaining pin and remove gearshift lever.

4) On vehicles without Cruise Command, remove directional signal switch lever. On vehicles with Cruise Command, remove wires from Cruise Command switch terminal. Fold two of four wires back and tape along harness. Tape a length of string to harness to aid removal.

5) Remove hazard warning switch knob by pressing in and unscrewing. Disconnect directional signal switch connector at bracket on lower steering column. Remove wiring harness plastic connector from column jacket.

6) Wrap tape around directional signal switch connector to prevent snagging when removing. Remove directional signal switch retaining screws. Pull switch and harness straight up and out of column.

7) On vehicles with Cruise Command, remove directional switch lever. Remove Cruise Command switch (in directional signal switch lever) and harness using string taped to harness.

8) Insert ignition key in lock cylinder. Turn key to "LOCK" position. Compress cylinder retaining tab and remove lock cylinder. The retaining tab is reached through slot next to directional signal switch boss in housing.

**NOTE:** If retaining tab is not visible through slot, remove any casting flash that may be in slot.

9) Remove shift quadrant by prying two spring clips out of column. Remove mounting bracket and light socket. Remove tilt release handle. Remove cover retaining screws and remove cover.

10) Remove lock sector tension spring screw. Unlock sector spring from sector shaft. Remove snap ring

from sector shaft. Remove sector, shaft and retaining ring. Install tilt release handle. Place column in full upward tilt position.

11) Insert a screwdriver in tilt release spring retainer slot and compress retainer approximately  $\frac{3}{16}$ ". Rotate retainer  $\frac{1}{8}$  turn and remove retainer and spring.

**CAUTION:** Tilt spring is under strong tension.

12) Place housing in center position. Using a puller (J-21854-1) remove tilt pivot pins. See Fig. 10. Lift tilt release lever to disengage lock shoes and remove housing. Remove both ball bearing assemblies from housing (if necessary).

Fig. 10: Removing Tilt Pivot Pins

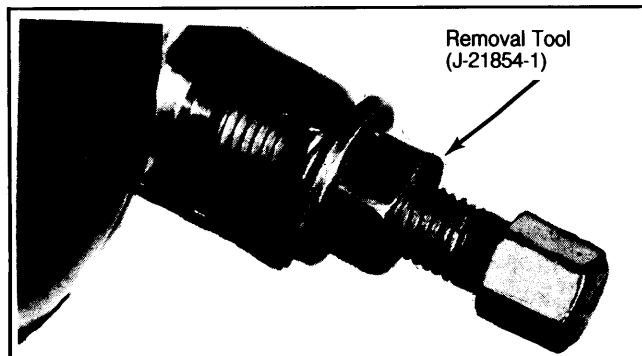

13) Remove tilt release lever. Using a punch, drive out release lever pin. Compress lock shoe spring to release spring tension on pin. See Fig. 11.

Fig. 11: Tool Arrangement for Removing and Installing Piston Pin

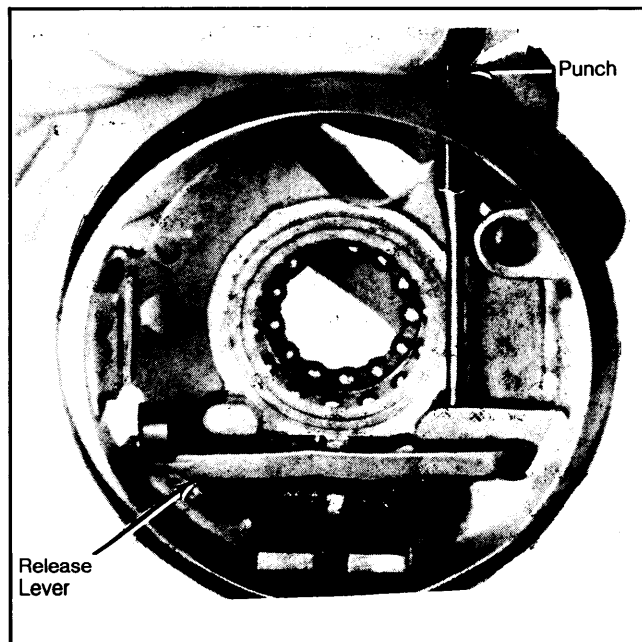

14) Using a punch, drive out lock shoe pin. Compress lock shoe spring to release spring tension on pin. Remove lock shoes and lock shoe springs. Disconnect steering shaft. Remove shaft through upper end of column. See Fig. 12.

## JEEP (Cont.)

**Fig. 12: Removing Lock Shoe Pin**

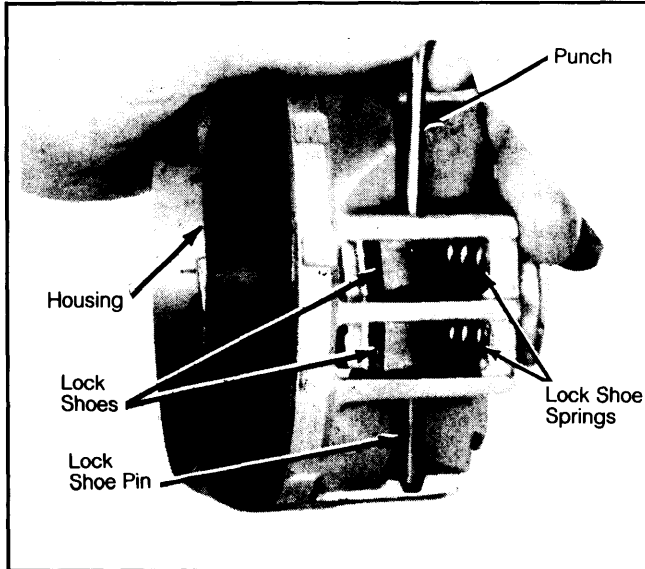

15) Fold shaft at 90° and separate upper and lower halves at flex joint. Remove ignition switch. Remove lock rack and remote rod. Remove lower bearing retainer snap ring, retainer, bearing and adapter.

16) Remove screws securing support shift bowl. Remove shift gate screws and remove shift gate from support. Remove support and shift tube retaining ring and thrust washer. Using a puller (J-23072), pull shift tube from column.

17) Rotate shift bowl clockwise while sliding retainer plate out of jacket notches. Tip plate down toward shift bowl hub at 12 o'clock position and remove plate, bottom side first.

18) Remove wave washer and shift tube spring. Remove shift bowl from column jacket. Remove lower bearing retainer spring clip. Remove retainer, lower bearing and bearing adapter.

### Reassembly

1) Coat all friction surfaces with multi-purpose grease before reassembly. Mount shift bowl on column. Place shift tube spring, wave washer, and retainer plate in shift bowl.

2) Install shift tube through lower end of column. Make sure tube spline is aligned with shift bowl keyway. Place shift tube installed tools (J-23073-2 and J-23073-4) in shift tube. Make sure spring loaded lower foot of tool is engaged with shift tube inner shoulder and tool guide is seated in shift tube. See Fig. 13.

3) Tighten tool spring tension nut until snug. Place installer tools (J-23073-3 and J-23073-4) over puller stud. Tighten tool nut (J-23073-2) and pull tube into place in shift bowl. Remove shift tube installer tools. See Fig. 14.

4) Install shift tube thrust washer and retainer plate snap ring. Install lower bearing adapter, making sure notched end of adapter faces lower end of column. Install lower bearing in column. Make sure metal face of bearing faces lower end of column. Install lower bearing retainer and retainer spring clip.

5) Install shift gate in support and install shift gate attaching screws. Install support in shift bowl. Make sure "V" notch in support is aligned with notch in column. Install support to shift bowl screws.

**Fig. 13: Positioning Shift Tube Installer Tools**

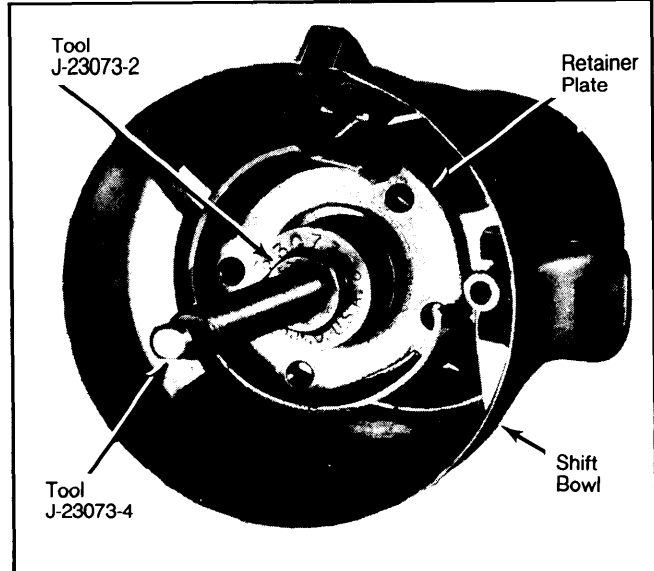

**Fig. 14: Pulling Shift Tube into Shift Bowl**

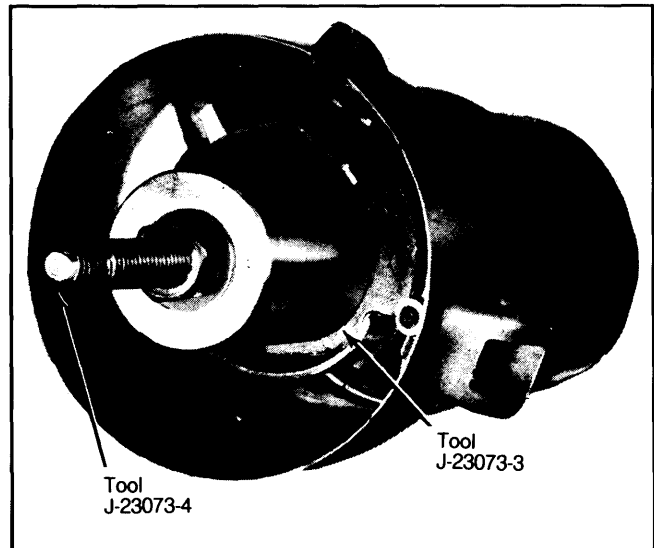

6) Assemble upper and lower steering shaft at flexible joint. Install steering shaft through upper end of column. Install ball bearings in housing if removed. Make sure there are 14 balls in each bearing.

7) Install tilt release handle. Insert ignition switch remote rod between shift bowl and column and into guide channel in left side of support. Engage lock rack in remote rod. Guide housing over steering shaft and lock rack, making sure lock shoes align with teeth in support.

8) Align housing and support pivot pin holes and drive in pivot pins using a soft faced mallet. Install lock shoe spring, tilt bumpers and lock pin in housing. Install sector shaft in housing and lock sector in on shaft. Large block tooth of sector must engage large slot in rack.

9) Install sector shaft snap ring. Hook lock sector tension spring on lock bolt. Engage spring with sector and install spring retaining screw. Place housing in full upward tilt position. Install tilt spring and guide in housing.

# Steering Columns

## JEEP (Cont.)

Fig. 15: Exploded View of Tilt Wheel Steering Column (All Except "CJ" & Scrambler Models)

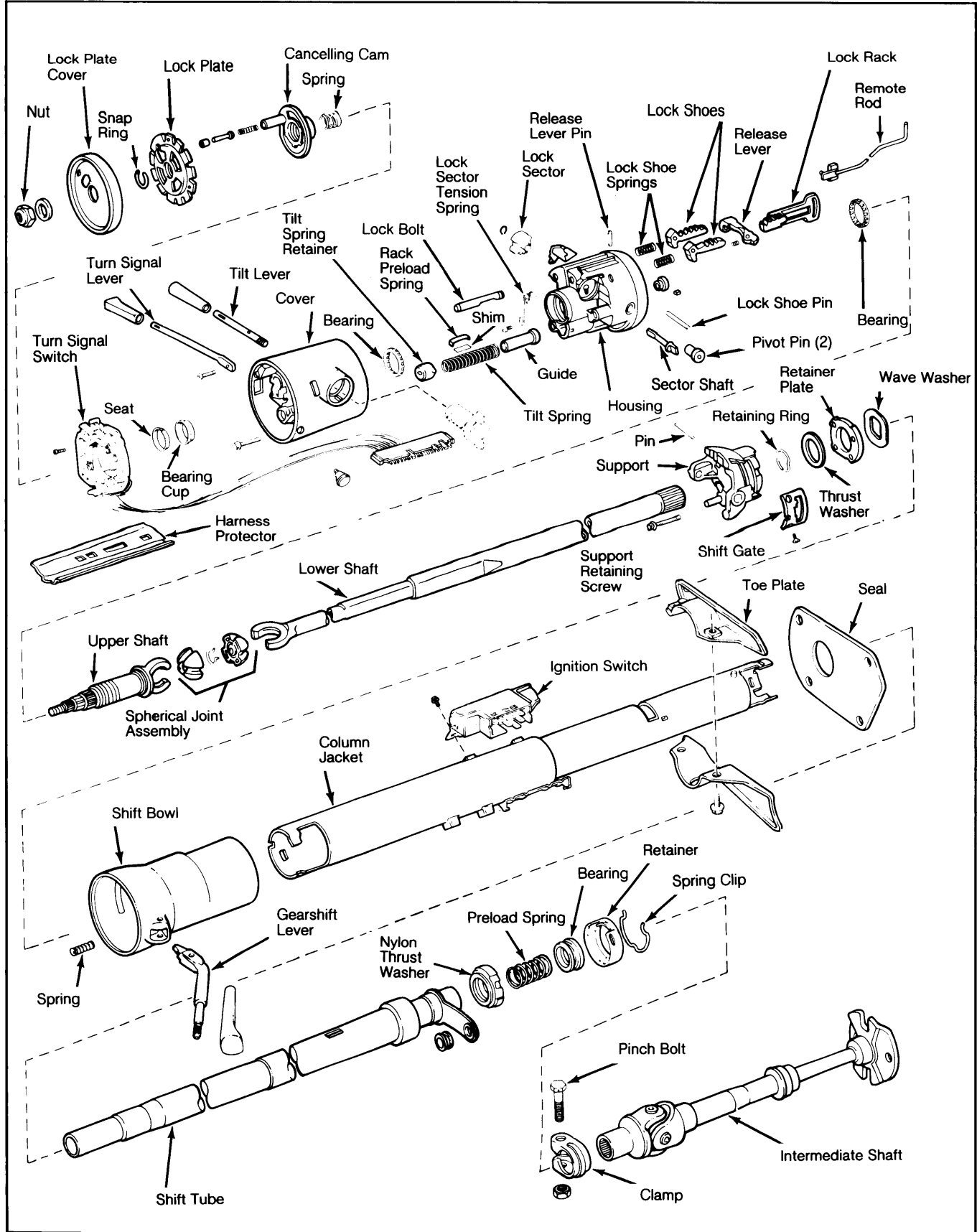

## JEEP (Cont.)

10) Push tilt spring retainer into housing 3/16" and rotate retainer 1/8 turn clockwise to secure retainer tabs in housing lugs. Place housing in center tilt position. Remove tilt release handle. Install cover on housing and install retaining screws.

11) Insert shift quadrant light wire up through housing and between shift bowl and column jacket. Install shift quadrant mounting bracket and connect light socket. Hook base of shift quadrant over tabs on left side of quadrant and place in position.

12) Install quadrant pointer in shift bowl and engage in quadrant. Install quadrant retainer clip with flat side of clip facing downward. Install tilt release handle. Place directional signal switch and harness in column. Guide harness between cover and column.

13) On vehicles without Cruise Command, install directional signal lever. On vehicles with Cruise Command, install directional signal lever and Cruise Command switch assembly. Use string taped to connector during disassembly to install connector.

14) Remove tape and string from connector. Connect four wires to switch terminal. Install and tighten lever screw. Place directional signal switch harness in plastic protector. Align directional signal switch in cover. Install and tighten retaining screws.

**NOTE:** Make sure switch actuating lever pivot is correctly aligned and seated in housing pivot boss before installing switch attaching screws.

15) Install bearing race, bearing race seat, preload spring, and cancelling cam on steering shaft. Align lock plate splines with steering shaft splines. Install lock plate. Make sure cancelling cam shaft protrudes through hole in lock plate.

16) Install new steering shaft snap ring on lock plate compressor tool (J-23653 for American threaded steering shaft nut, J-23653-4 for metric threaded nut). Position tool on steering shaft. Compress lock plate with tool. Install snap ring in groove in steering shaft. Remove tool.

17) Place gearshift lever in shift bowl. Guide gearshift lever over lock sector tension spring and into bowl. Align retaining pin holes with a punch. Drive retaining pin into position using a soft faced hammer.

18) Insert ignition key into lock cylinder. Hold lock cylinder and turn key clockwise to stop. Align cylinder locking lug with keyway in cover and insert cylinder in cover. Push cylinder against lock sector. Rotate cylinder counterclockwise until it engages sector. Push cylinder inward until retainer tab snaps into place.

19) Install steering column as previously outlined. Install steering wheel. Adjust gearshift linkage, and neutral safety and back-up lamp switch.

### TILT WHEEL

#### Disassembly ("CJ" & Scrambler Models)

1) Remove steering column as previously outlined. Remove mount bracket from column. Attach a holding fixture (J-23074) to mount bolt holes. Secure column in vise by clamping on holding fixture. See Fig. 19.

2) Remove steering wheel. Remove gearshift lever retaining pin and remove lever (if equipped). Remove lock plate cover. Remove tilt and turn signal levers. Remove hazard warning knob by pressing in and turning counterclockwise.

3) Compress lock plate using a suitable compressor tool (J-23653 for American threaded steering shaft nut, J-23653-4 for metric threaded nut). Remove snap ring from groove in steering shaft. Remove tool and discard snap ring.

4) Remove lock plate, cancelling cam and upper bearing preload spring. Disconnect turn signal switch harness at lower end of column. Remove wire harness protector from column. Wrap tape around harness to prevent snagging on removal.

5) Remove turn signal switch attaching screws and remove switch and harness. Pull switch straight up out of column. Insert ignition key in lock cylinder and turn key to "ON" position. Compress lock cylinder retaining tab with small screwdriver and remove cylinder.

**Fig. 16: Removing Upper Bearing Race and Seat**

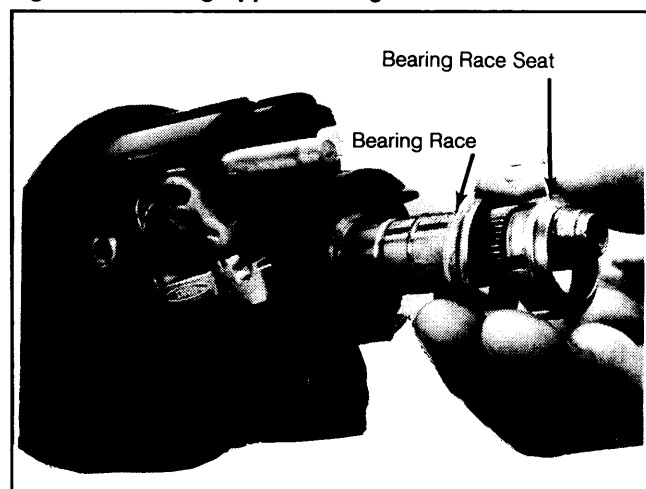

**NOTE:** The retaining tab is accessible through the slot next to turn signal switch mounting boss. If tab is not visible, remove any casting flashing that may be in slot.

6) Remove cover retaining screws and remove cover. Remove upper bearing race and bearing seat from steering shaft. Reinstall tilt lever and place column in full up position. See Fig. 16.

7) Remove tilt spring, guide and retainer with screwdriver. Press retainer inward and turn counterclockwise until retainer tabs align with housing lugs.

8) Place housing in center position. Remove housing pivot pins using tool J-21854-1. Raise tilt lever to disengage lock shoes and remove housing. Pull housing upward to disengage shoes, and turn housing to one side to separate lock rack from remote rod.

9) Remove tilt lever and shield from housing. Remove lock sector spring retaining screw and spring. Rotate spring clockwise to remove. Remove lock sector retaining ring, lock sector and sector shaft. Tap shaft through sector and out of housing with a hammer and punch. See Fig. 17.

10) Remove lock bolt, lock rack, rack preload spring, shim and remote rod from housing. Insert wedge between lock shoes and housing to relieve spring tension on tilt and lock shoe pins.

11) Remove tilt lever pin from housing with pin punch. Remove lock shoe pin from housing with pin punch, and remove lock shoes, springs and wedge.

# Steering Columns

## JEEP (Cont.)

**Fig. 17: Removing Lock Sector and Sector Shaft**

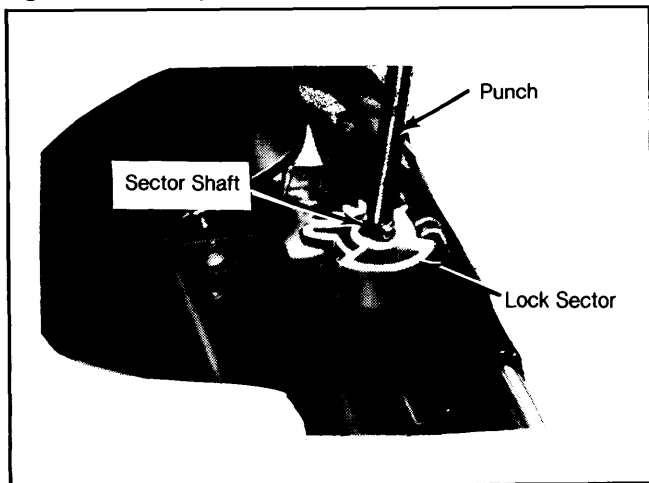

12) Remove upper and lower housing bearings and races, if damaged or worn. If removed, discard and replace with new races and bearings. Disconnect steering shaft at coupling.

13) Remove steering shaft through upper end of column. Remove support attaching bolt and remove support. Remove retainer plate. Tip upper end of plate rearward and turn plate counterclockwise to remove.

14) Remove shroud using twisting-pulling motion. Remove key release lever and lever spring from shroud. Tip lever forward and lift up to remove. See Fig. 18.

15) Disconnect ignition switch wire harness connector and remove switch. Remove snap ring, retainer and bearing assembly from lower end of column.

**Fig. 18: Removing Support from Housing**

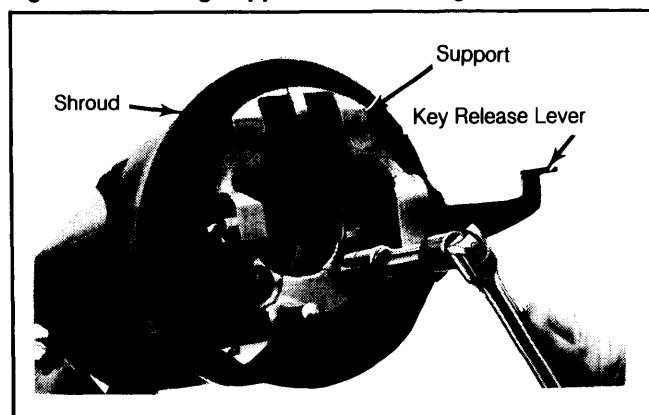

### Reassembly

1) Coat all friction surfaces with multipurpose grease before reassembly. Install bearing assembly, bearing retainer and snap ring in lower end of column.

2) Install key release lever spring on lever and install assembled lever and spring in shroud. Align and install shroud on column jacket.

3) Install retainer plate by tipping plate to 12 o'clock position and sliding it under jacket opening. Align column jacket "V" notch with "V" on support and install support in column. Press key release lever down while pressing support into place.

4) Install support attaching screws finger tight then tighten alternately to specifications. Install remote rod in support by guiding rod through upper end of shroud and into rod slot in support.

5) Install steering shaft in column. Install bearings (if removed). Install lock shoe, springs and lock shoe pin in housing. Use .18" (4.6mm) diameter rod to align lock shoes and pin.

6) Install release lever, lever spring and lever pin in housing. Insert wedges between housing and lever to relieve spring tension. Install sector shaft in housing. Lightly tap shaft into housing using punch.

7) Install lock sector on shaft. Lightly tap sector onto shaft until shaft snap ring groove is exposed. Install sector snap ring. Install lock bolt in housing and engage bolt in lock sector cam surface.

8) Install lock rack, rack preload spring and shim in housing. Square block tooth of rack must engage square block tooth of sector. Install lock spring and retaining screw.

9) Align and install assembled housing on support. Hold lock shoes in disengaged position to ease housing installation. Align pivot pin holes in housing and support and install pivot pins. When started in holes, seal pins fully using a hammer and punch. Press housing downward when first installing pins to avoid damage to pin holes.

10) Insert tilt lever in housing and place housing in full upward tilt position. Lubricate tilt guide and spring and install tilt spring on guide. Insert assembled tilt spring and guide in housing and install guide retainer on spring.

11) Install tilt lever shield. Remove tilt lever. Install cover on housing. Install turn signal switch. Guide switch harness and connector through column and into housing. Do not install switch attaching screws at this time.

12) Install hazard warning switch knob in turn signal switch and align and install switch attaching screws. Make sure turn signal switch is properly aligned before tightening screws. Pull out on hazard warning knob.

13) Install upper bearing race and seat in housing. Install upper bearing preload spring, cancelling cam and lock plate.

14) Install new steering shaft snap ring on compressor tool (J-23653 for American threaded steering shaft nut, J-23653-4 for metric threaded nut) and install tool on steering shaft. Compress lock plate and seat snap ring. Remove tool.

15) Install tilt and turn signal levers. Install shift lever and retaining pin. Install ignition lock cylinder. Hold cylinder sleeve, turn knob clockwise against stop, align cylinder tab with housing keyway and install cylinder in housing. Turn cylinder knob counterclockwise until cylinder mates with lock sector and push cylinder in until retainer snaps into place.

16) Insert key in cylinder and turn cylinder to "OFF" position. Install ignition switch. Move switch to "ACC" position then back off two clicks to "OFF" position. Remote rod hole should almost be at center.

17) Insert remote rod into hole and install switch on column jacket. Move switch down to eliminate lash and tighten attaching screws. Position switch harness protectors over harness and snap into place.

18) Install lock plate cover. Install steering wheel. Install column in vehicle.

