

GENERAL MOTORS SLIDING CALIPER DISCS

Chevrolet, GMC

NOTE: Bendix sliding caliper disc brakes are used on all models equipped with Bendix Hydro-boost power units, 4-wheel disc brakes, and/or diesel engines. All other models use Delco floating caliper disc brakes. See appropriate article in this section.

DESCRIPTION

Bendix sliding caliper disc brakes use a single piston caliper. Front calipers are attached to a mount integral with the steering knuckle. Rear calipers are mounted to an adapter bolted to the drive axle.

When brakes are applied, hydraulic pressure is passed to caliper piston. This force is transmitted to inner brake pad against inner rotor braking surface. Pressure then moves caliper inward, forcing outer disc pads against outer braking surface.

When brake pedal is released, pressure is removed from caliper cylinder and rotor runout moves piston back into caliper cylinder to maintain sufficient rotor-to-pad clearance.

ADJUSTMENT & SERVICING

DISC PAD ADJUSTMENT

Pad wear is automatically compensated for by piston moving outward in cylinder bore. No disc pad adjustment is required. Inspect condition of disc pads whenever wheels are removed. If any pad is worn to within $\frac{1}{32}$ " (.8 mm) of rivet heads, replace complete pad set.

PARKING BRAKE

See *Parking Brake Adjustment in General Motors Single Anchor Brake System* in this section.

BLEEDING SYSTEM

See *Hydraulic Brake Bleeding* in this section.

REMOVAL & INSTALLATION

DISC BRAKE PADS

Removal

1) To prevent master cylinder overflow when caliper is depressed, remove $\frac{2}{3}$ of the brake fluid from master cylinder. Raise vehicle and remove wheel. Place a large "C" clamp on caliper and tighten clamp on bottom piston in cylinder bore. Remove clamp.

2) Remove key retaining screw. Drive out caliper support key and spring with brass rod and light hammer. Remove caliper by pushing down against mount and rotating up and away from mount. Support caliper with wire. Do not let caliper hang with weight on brake hose.

3) Remove inner disc pad and shoe clip from caliper. Remove outer disc pad from caliper. It may be necessary to tap pad to loosen it in caliper housing.

Installation

1) Lubricate caliper and mount sliding surfaces with silicone lubricant. Install new anti-rattle clip in mount.

Place lower end of inner pad into mount and against anti-rattle clip, then slide upper end of pad into place. Be sure clip is still in correct position.

2) With caliper piston fully bottomed in cylinder bore, position outer pad on caliper and press tabs into place. If pad cannot be properly positioned by hand, use a large "C" clamp, taking care not to mar lining.

3) With disc pads installed, lift caliper and rest bottom edge of outer pad on outer edge of rotor. Check that there is no clearance between bottom tab of outer pad and caliper abutment. Outer pad should be tight in caliper housing.

4) Position caliper on mounting surface. Place spring over support key and tap into place until key retaining screw can be installed. Tighten screw. Fill master cylinder with new brake fluid. Reinstall wheel and lower vehicle.

Fig. 1: Rear Sliding Caliper Disc Brake Components

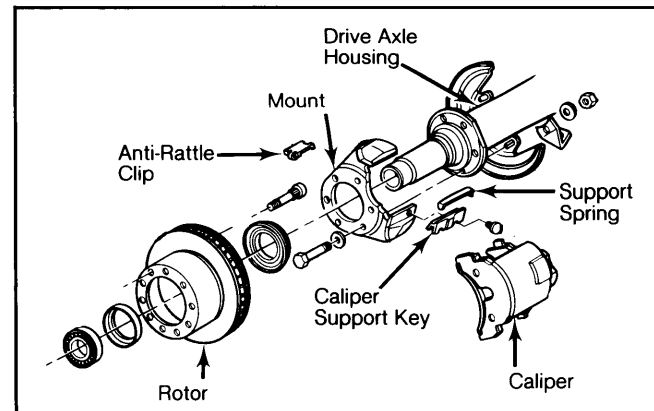

BRAKE CALIPER

Removal & Installation

Caliper removal and installation procedures are the same as those for disc pad replacement, except that it will be necessary to disconnect brake hose. Use new copper washers when reconnecting brake hose.

DISC ROTOR

Removal (2-WD Models)

1) Raise vehicle and position on safety stands. Remove brake caliper without disconnecting brake line.

2) Remove grease cover from end of hub. Remove cotter pin, nut, washer and outer bearing. Remove rotor and hub assembly.

Installation

Install rotor and hub assembly on spindle. Install outer bearing, washer and nut. Adjust wheel bearing. See *Wheel Bearing Adjustment in SUSPENSION section*

Removal & Installation (4-WD Models)

Raise and support vehicle on safety stands. Remove wheel and tire. Remove locking hub. See *Locking Hub article in DRIVE AXLE section*. Remove wheel bearing lock nut, lock ring and adjuster nut. Remove rotor and hub assembly. To install, reverse removal procedures and adjust wheel bearing. See *Wheel Bearing Adjustment in SUSPENSION section*.

Removal (Rear Wheel Disc Brakes)

1) Raise vehicle and position on safety stands. Remove brake caliper without disconnecting brake line.

Brake Systems

GENERAL MOTORS SLIDING CALIPER DISCS (Cont.)

2) Remove axle shaft flange bolts and remove drive axle. Bend lock tab on bearing lock nut and remove lock nut. Remove lock tab assembly. Remove inner bearing adjusting nut and washer. Remove rotor and hub assembly.

Installation

1) Install rotor and hub assembly into position on axle housing. Install outer bearing and washer. Make sure tang on washer is aligned with groove in axle housing.

2) Install inner bearing nut and adjust wheel bearings. See *Wheel Bearing Adjustment in SUSPENSION section*.

3) Install drive axle shaft using a new flange gasket. Tighten bolts to 115 ft. lbs. (156 N.m). Install brake caliper as previously outlined.

OVERHAUL

BRAKE CALIPER

Disassembly

1) Wipe caliper clean around inlet port and remove plug. Drain fluid from caliper housing. Place caliper assembly on bench (piston side up), and place several shop towels between piston and outer legs of caliper housing.

2) Carefully apply low-pressure air at caliper inlet port until piston comes out of caliper housing. If piston is seized, lightly tap around end of piston with soft-faced hammer. Do not attempt to catch piston by hand, since it may pop out of caliper with some force.

Fig. 2: Using Compressed Air to Remove Caliper Piston

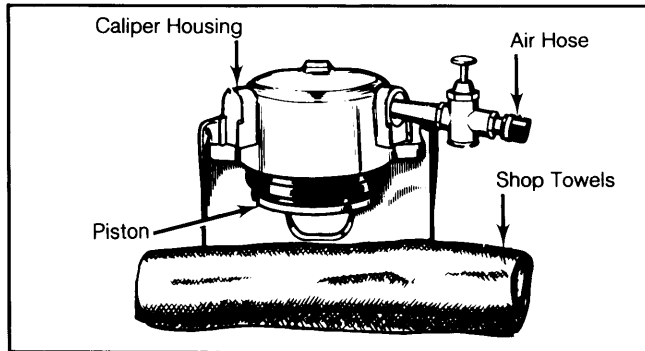

Place shop towels under caliper to catch piston.

Fig. 3: Exploded View of Sliding Caliper Assembly

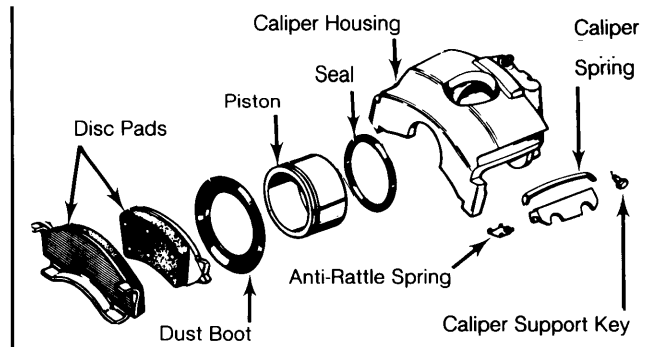

3) Remove boot from piston and seal cylinder bore. Clean caliper housing and piston denatured alcohol. Check cylinder bore, seal groove, boot groove for damage or excessive wear. piston if pitted.

Reassembly

To assemble caliper, soak all parts in brake fluid and reverse disassembly procedure. Use "C" clamp to seat piston in cylinder bore.

DISC ROTOR

Lateral Runout

Adjust wheel bearings until all end play eliminated. Attach dial indicator with contact tip indicator on braking surface approximately 1" (25) from rotor edge. Set indicator to zero and turn through one complete revolution, noting indicator reading.

Parallelism

Check thickness of rotor at 4 or more around circumference of rotor. Make all measurements same distance from edge of rotor. If thickness variation excessive, refinish or replace rotor as necessary.

TIGHTENING SPECIFICATIONS

Application	Ft. Lbs. (N.m)
Brake Line-to-Caliper	32 (44)
Support Key Retaining Screw	18 (24)
Caliper Mounting Bolts	35 (48)
	INCH Lbs. (N.m)
Hydraulic Line-to-Brake Hose	150 (17.0)
Bleeder Valve Screws	60 (6.8)

DISC BRAKE ROTOR SPECIFICATIONS

Application	Disc Diameter In. (mm)	Lateral Runout In. (mm)	Parallelism In. (mm)	Original Thickness In. (mm)	Min. Refinish Thickness In. (mm)	Discard In. (mm)
S10/15 & All w/Diesel Engine	11.86 (301.2)	.004 (.10)	.0005 (.013)	1.28 (32.5)	1.23 (31.2)	1.22 (30.9)
All Others						
Front (Drum Rear)	12.50 (317.5)	.004 (.10)	.0005 (.013)	1.53 (38.9)	1.48 (37.6)	1.47 (37.2)
Front (Disc Rear)	14.25 (361.9)	.004 (.10)	.0005 (.013)	1.53 (38.9)	1.48 (37.6)	1.47 (37.2)
Rear	13.75 (349.3)	.004 (.10)	.0005 (.013)	1.53 (38.9)	1.48 (37.6)	1.47 (37.2)