

Power Brake Units

BENDIX SINGLE DIAPHRAGM

Chevrolet, Ford, GMC

DESCRIPTION

This unit uses engine manifold vacuum and atmospheric pressure to assist braking. Vacuum power unit contains power piston assembly, which houses control valve, reaction mechanism and return spring. Control valve consists of air valve, floating control valve assembly, and push rod. Reaction mechanism includes reaction plate and levers. A vacuum check valve is mounted in front housing for connection to vacuum source.

REMOVAL & INSTALLATION

NOTE: Power brake unit can be removed without removing master cylinder or disconnecting brake lines.

Removal

Disconnect vacuum line from check valve or power unit. Remove nuts securing master cylinder to power unit. Pull master cylinder forward away from unit. Disconnect brake pedal from push rod. Remove power unit-to-firewall bolts and remove unit.

Installation

To install, reverse removal procedure.

OVERHAUL

NOTE: Only Chevrolet and GMC recommend overhaul of power brake unit.

Disassembly

1) Scribe mark on housings for reassembly. Remove front housing seal and piston rod. Attach assembly to holding fixture (J-22805). Align tool so that check valve in front housing is not damaged. Loosen lock nut and remove push rod clevis and lock nut (if equipped). Remove dust boot retainer, dust boot and silencer from diaphragm plate extension.

2) Partially straighten four deepest tabs on rear housing. Place spanner wrench (J-9504) over studs on rear housing and attach with nuts and washers. Press

down on wrench and rotate rear housing clockwise to separate. Remove wrench.

CAUTION: Housings are under spring pressure.

3) Remove air filter from diaphragm plate extension. Remove diaphragm from groove in diaphragm plate. Handle diaphragm carefully. Hold diaphragm plate so that push rod is in horizontal position. Depress rod slightly and rotate piston until air valve lock falls from diaphragm plate hub. Remove reaction disc from diaphragm plate bore, using push rod to push disc from seat.

CAUTION: Remove rear seal only if a new one is available. Do not reuse old seal.

4) Remove rear shell bearing seal with punch. Remove vacuum check valve and grommet.

Cleaning & Inspection

Use only clean brake fluid to clean all metal, plastic, and rubber parts. Blow out all passages, orifices, and valve holes with clean, dry air, and air dry all parts. Slight rust on inside of housing can be polished with crocus cloth or fine emery cloth. There should be no cut, nicks, or distortion of any rubber part.

Reassembly

1) Install vacuum check valve grommet with beveled edge on inside. Dip check valve in denatured alcohol and install. Install holding fixture (J-22805) on front housing. Install new rear housing seal in center hole, using tool (J-22677) to seat seal in recess (tool bottoms against housing when seal is in place).

2) Lubricate outer diameter of diaphragm plate and extension, bearing surfaces of air valve, and outer edge of valve poppet. Install valve and rod into diaphragm plate extension. Depress push rod slightly and install air lock valve (lock must index and retain air valve). Install rolling diaphragm in diaphragm plate hub groove. Lubricate reaction disc with silicone lubricant and install disc (use master cylinder push rod to seat disc in diaphragm plate bore).

NOTE: If disc is not seated, push rod height will be gauged incorrectly during adjustment.

3) Lubricate inside of bearing seal and diaphragm bead contact surface of rear shell. Install diaphragm plate assembly in rear housing. Place air filter

Fig. 1: Exploded View of Bendix Single Diaphragm Assembly

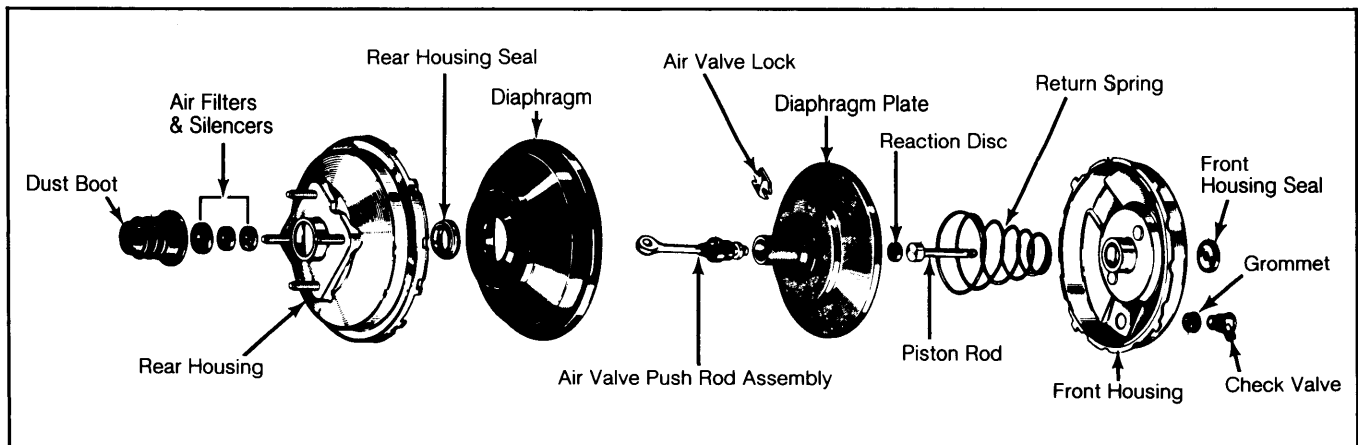

BENDIX SINGLE DIAPHRAGM (Cont.)

element over push rod and into diaphragm plate extension. Install filter retainer.

4) With holding fixture in place, position spanner wrench (J-9504) over studs on rear housing and position front and rear housings together. Press down on wrench and rotate rear housing counterclockwise to lock housings. Align scribe marks. Rebend tabs on rear housings. If tabs are cracked or broken, housing must be replaced. Remove wrench.

5) Install air silencers over push rod end. Install push rod boot and boot retainer. On clevis type push rods, install lock nut and push rod clevis. Lightly lubricate piston rod (except rounded end). Guide rod into center bore until fully seated against reaction disc. Press front housing seal into housing until seal is bottomed in recess of housing.

ADJUSTMENT

PUSH ROD

Chevrolet & GMC

1) Place power unit in a vise with front housing up. Remove front seal to ensure all vacuum is released from unit. Place master cylinder rod, flat end first, in piston rod retainer. Press down on rod with 50 lbs. (23 kg) pressure to make sure rod is seated.

Fig. 2: Checking Push Rod Height

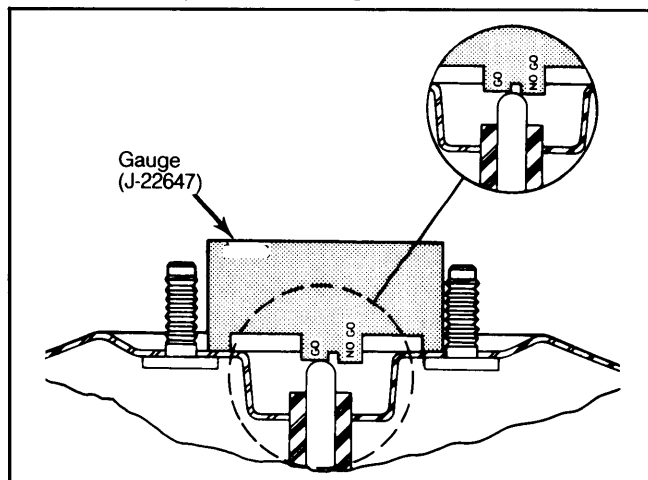

Chevrolet and GMC are checked with J-22647 gauge.

2) Place gauge (J-22647) over piston rod so it can be moved from left to right without contacting studs. The center section of gauge has two levels. The piston rod should always contact the lower level and never contact the highest level.

3) If the push rod does not contact gauge correctly, an adjustable push rod must be obtained. Adjust locking screw on rod to obtain correct clearance with gauge. Apply silicone lubricant on the inside diameter of front housing seal and place seal in position in housing depression.

Ford

Check distance from outer end of push rod to front face of unit. Use a locally-made gauge. See Fig. 3. Turn push rod screw in or out until length is .980-.995" (24.9-25.3 mm).

Fig. 3: Checking Push Rod Height

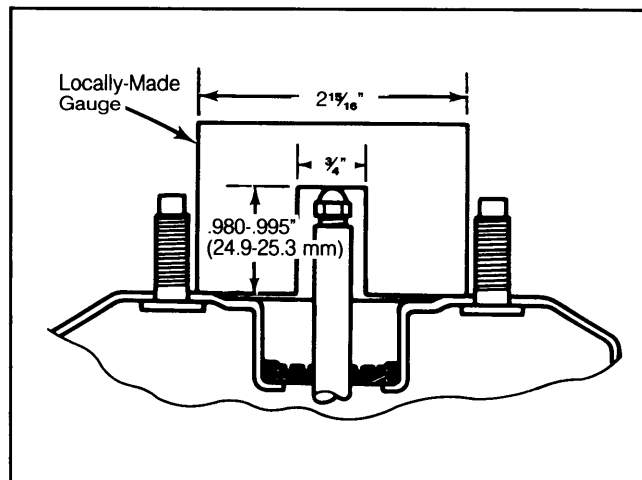

Ford models are checked with locally-made gauge.