

# Master Cylinders

## BENDIX/DELCO-MORAINÉ DUAL PISTON

Chevrolet, GMC, Jeep

**NOTE:** Some models may use other units; see Brake Systems Application Charts

### DESCRIPTION

Bendix and Delco-Moraine tandem dual piston master cylinders are single casting type with front and rear pistons and a separate reservoir and outlet for each piston. Rear piston is operated by push rod connected to brake pedal. Front piston is operated by rear piston. In a combination disc and drum system, reservoir which feeds disc brakes is larger to compensate for larger displacement of disc caliper cylinder.

Master cylinders for General Motors and some Jeep vehicles incorporate a quick take-up feature, that delivers a large volume of fluid at low pressure upon initial application of brakes. This fluid quickly displaces the retracted caliper, placing brake linings in contact with brake rotors and drums.

### ADJUSTMENT

#### BRAKE PEDAL

**NOTE:** Adjustment for vehicles equipped with power boosters is accomplished at power booster. See Power Brake Units in this Section.

#### All Models

Vehicles without power assisted brakes use a non-adjustable push rod. Push rod length is preset by manufacturer.

### REMOVAL & INSTALLATION

#### MASTER CYLINDER

##### Removal

Disconnect front and rear hydraulic brake lines at master cylinder and cover ends to prevent entry of foreign matter. On vehicles without power assist units, disconnect brake pedal push rod at brake pedal. Remove master cylinder attaching bolts and remove cylinder assembly from vehicle.

##### Installation

Position master cylinder on vehicle and install attaching bolts. Connect front and rear hydraulic brake lines to cylinder. Connect brake pedal push rod, if removed. Fill reservoir with clean brake fluid and bleed hydraulic system. See *Hydraulic Brake Bleeding in this Section*.

### OVERHAUL

#### MASTER CYLINDER

##### Disassembly

1) Clean outside of cylinder thoroughly and remove cover. Drain fluid, turn cylinder over, and pump piston to remove any remaining fluid. On Jeep Cherokee, Wagoneer and truck models, remove reservoir with a pry bar. Remove reservoir grommets, retaining ring and quick-take-up valve.

2) On manual brake models, remove boot from cylinder to uncover push rod retainer. Pry up retainer tab to release retainer. On all models, push piston down into cylinder bore. Remove secondary piston stop bolt from front fluid reservoir (if equipped). Remove snap ring from groove in cylinder bore.

3) Remove both piston assemblies. Remove any internal parts remaining in bore. On Jeep "CJ" and Scrambler models, remove push rod from primary piston. Remove and discard all rubber parts from piston assemblies.

4) On General Motors and Jeep "CJ" and Scrambler models, enlarge holes in tube seats using a  $\frac{13}{16}$ " drill. Place a large flat washer over outlets and thread a  $\frac{1}{4}$ " x 20 x  $\frac{3}{4}$ " screw into seat. Remove seat, screw and washer. On all other Jeep models, thread a 6 x 32 x  $\frac{5}{8}$ " self tapping screw into tube seat and push upward with 2 screwdrivers to remove seat.

**Fig. 1: Removing Tube Seat from Master Cylinder**

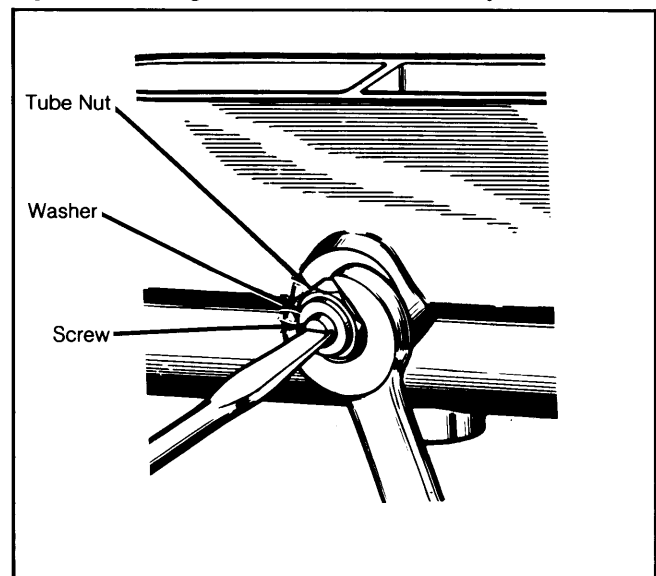

*GM and Jeep "CJ" and Scrambler models, only.*

##### Inspection

Inspect cylinder bore for scoring or corrosion. Staining which has not pitted or roughened surface of cylinder can be removed with crocus cloth. If cylinder bore is scored, pitted or corroded, master cylinder should be replaced.

##### Reassembly

1) Install replacement tube seats by threading a spare brake line tube nut into hole and turning nut in until tube seat bottoms. Do not cock tube seat in hole. Remove nut and check for burrs which may have been loosened by nut.

2) Install piston cups on secondary piston, with cup lips facing away from each other. Install seal protector, piston seal, spring retainer and return spring on secondary piston. Install seal so lip faces interior of master cylinder when installed.

3) Lubricate cylinder bore with clean brake fluid and install secondary piston assembly. Lubricate primary piston seals and install primary piston assembly in bore. Hold primary piston down in bore and install snap ring in groove.

## BENDIX/DELCO-MORaine DUAL PISTON (Cont.)

4) Install secondary piston stop bolt (if equipped). Install master cylinder reservoir, grommets and quick take-up valve (if removed). Install master cylinder cover and new diaphragm. On vehicles with manual

brakes, assemble brake pedal push rod through retainer (if used), and push retainer over end of master cylinder. Install rubber boot over push rod.

**Fig. 2: Exploded View of Typical Delco-Moraine Master Cylinder — Bendix Similar**

