

GENERAL MOTORS

**Chevrolet
GMC**

DESCRIPTION

All Models — Collapsible steering columns with internal shift linkage and function locking features are used. Tilt steering wheel features are available on all models.

REMOVAL & INSTALLATION

CAUTION — When working on a collapsible steering column, do not bump or hammer on column components. With the column removed from mounts, it is extremely susceptible to impact damage. A slight impact on the column end may collapse steering shaft or loosen plastic injections which maintain column rigidity. When removing the steering wheel, use a puller but do not hammer on puller to aid removal.

NOTE — Correct column installation is important to prevent stress on collapsible components during mounting. Using improper screws, nuts and bolts could prevent assembly from compressing under impact.

"C" & "K" MODELS

Removal — 1) Loosen front of dash mounting plates. Disconnect battery ground cable. Remove steering wheel. Remove nuts and washers securing flanged end of steering shaft to flexible coupling. Disconnect transmission control linkage from column shift tube levers.

2) Disconnect steering column harness at connector. Disconnect neutral start switch and back-up lamp switch connectors if so equipped. Remove floor pan trim cover screws and remove cover. Remove screws securing two halves of floor pan cover, then remove screws securing halves and seal to floor pan and remove covers. Remove transmission indicator cable if so equipped.

3) Move front seat as far back as possible to provide maximum clearance. Remove two column bracket-to-instrument panel nuts and carefully remove column from vehicle, rotating column so that shift levers will clear hole in floor pan.

Installation — 1) Assemble upper and lower dash covers to seal using seal carrot locks. Attach bracket to steering column. Tighten four retaining bolts to specification.

NOTE — If rag joint coupling was removed from steering gear shaft, it must be installed before steering column is installed in car.

2) Position steering column in vehicle. Assemble flange to rag joint. Install lock washers and nuts. Tighten nuts to specification. Loosely install two bracket nuts to dash studs.

3) Install lower clamp (engine side of firewall) and tighten nuts to specification. Install seal, upper and lower covers to cab side of firewall. Tighten two upper bracket nuts to specification.

4) Remove plastic spacers from flexible coupling. Install automatic transmission indicator cable (if equipped with automatic transmission).

5) Install instrument panel trim cover. Connect transmission control linkage. Install steering wheel. Connect battery ground cable.

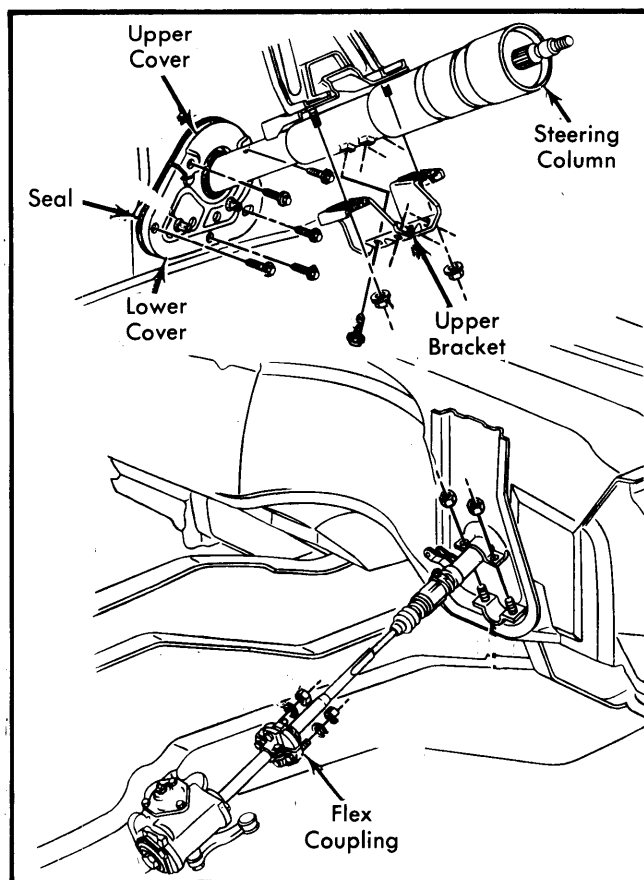

Fig. 1 "C" & "K" Models Steering Column Installation

"G" & "P" MODELS

Removal — 1) Disconnect battery ground cable. On column shift models, disconnect shifter rods at lower end of column. On "G" models, remove steering shaft flange-to-flexible coupling bolts. On "P" models, remove intermediate steering shaft upper universal yoke-to-steering shaft pinch bolt and mark coupling to shaft relationship. On all models, remove column clamp screw(s) on engine side of firewall, if necessary, then slide cover and seal down on column.

2) From inside vehicle, remove screws from floor pan cover and slide cover and seal up column. Remove steering wheel, then reinstall retaining nut and washer to prevent dislocation of steering shaft. Disconnect directional wiring harness. On standard columns with automatic transmission, disconnect conductor tube for transmission indicator at instrument panel.

3) Disconnect single wire at fuse block and unclip it from parking brake bracket on tilt column models with automatic transmission. On all models, remove cap screws from column support bracket at dash panel. Carefully lower, then raise and withdraw column assembly, rotating it so that shift levers clear hole in floor pan.

GENERAL MOTORS (Cont.)

Installation ("P" Models Only) — 1) Applying 50 ft. lbs. force on steering wheel end of steering shaft, adjust lower bearing preload to allow steering shaft end play. Tighten shaft clamp on pot joint bolt. Carefully insert lower end of column assembly into hole in floor pan. Guide steering shaft into universal yoke, lining up marks made at removal. Install yoke pinch bolt and tighten. Pinch bolt must pass through shaft undercut.

2) Position and attach lower clamp mounting bracket to firewall. Locate steering column protrusions against floor pan bracket while at the same time, aligning protrusion on clutch and brake pedal support with index slot on column jacket. Install column-to-bracket clamp and tighten bolt.

NOTE — Do not allow toe pan bracket to override protrusions on steering column jacket.

3) Position steering column-to-dash panel bracket and install and tighten bolts. Install seal at floor pan, then install bracket screws and tighten. Install dash panel trim plate, if equipped. Connect transmission shift linkage on column shift models.

4) On all models, connect directional signal wiring harness. On non-tilt columns with automatic transmissions, connect conductor tube for transmission indicator to instrument panel. On all models, install steering wheel and connect battery ground cable.

Installation ("G" Models Only) — 1) Adjust column lower bearing preload by applying a force on steering wheel end of shaft, then position spring and clamp to maintain dimension as shown in Adjustment. Install plastic spacers onto flexible coupling alignment pins. From inside vehicle, carefully insert lower end of column through floor pan opening, guiding steering shaft flange onto flexible coupling. Install and tighten flange-to-coupling bolts

2) Locate index slot in column jacket with protrusion on clutch and brake pedal support. Loosely install column-to-dash bracket and screws. Push column down until steering shaft flange bottoms on plastic spacers on flexible coupling and tighten bracket screws.

3) Remove plastic spacer from alignment pins. Check that the rag joint-to-steering shaft flange clearance is .250-.325". If not within specifications, bracket screws must be loosened and column raised or lowered as required. Retighten screws.

4) Push floor pan seal to floor pan; install and tighten screws. Connect directional signal switch wiring harness. On vehicles with automatic transmissions, connect conductor tube for transmission indicator to instrument panel. On all models, install steering wheel. Connect transmission linkage and battery ground cable.

OVERHAUL

**"C" & "K" MODELS
WITHOUT TILT WHEEL**

Disassembly — 1) Remove four dash panel bracket-to-column screws and lay bracket in safe place to prevent damage to mounting capsules. Place column in a vise using both weld nuts of set "A" or "B". See Fig. 2.

CAUTION — Do not place column in vise by clamping onto only one nut or by clamping onto sides of nut not indicated by arrows in Fig. 2.

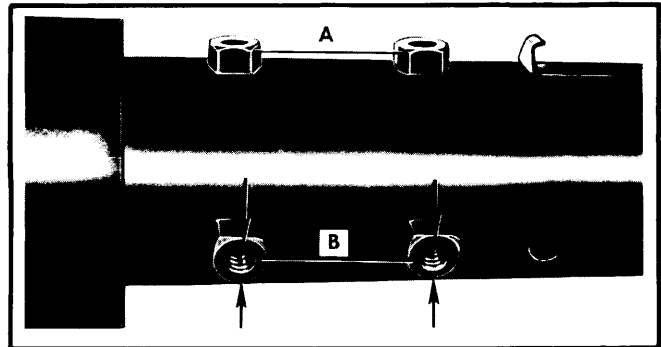

Fig. 2 Correct Installation of Steering Column in Vise

2) Remove directional signal switch, lock cylinder, and ignition switch. Drive out upper shift lever pivot pin and remove shift lever on column shift models. Remove upper bearing thrust washer. Remove four screws attaching directional signal and ignition lock housing to column and remove housing assembly. Remove thrust cap from lower side of housing.

3) Lift ignition switch actuating rod and rack assembly, rack preload spring, and shaft lock bolt and spring assembly out of housing. Remove shift lever detent plate (shift gate). Remove ignition switch actuator sector through lock cylinder hole by pushing firmly on block tooth of sector with a screwdriver or punch. Remove gearshift lever housing and shroud from jacket assembly (transmission control lock tube housing and shroud on floor shift models).

4) Remove shift lever spring from gearshift lever housing (lock tube spring on floor shift models). Pull steering shaft from lower end of jacket assembly. Remove two screws holding back-up switch or neutral start switch to column and remove switch. Remove lower bearing retainer clip. See Fig. 3.

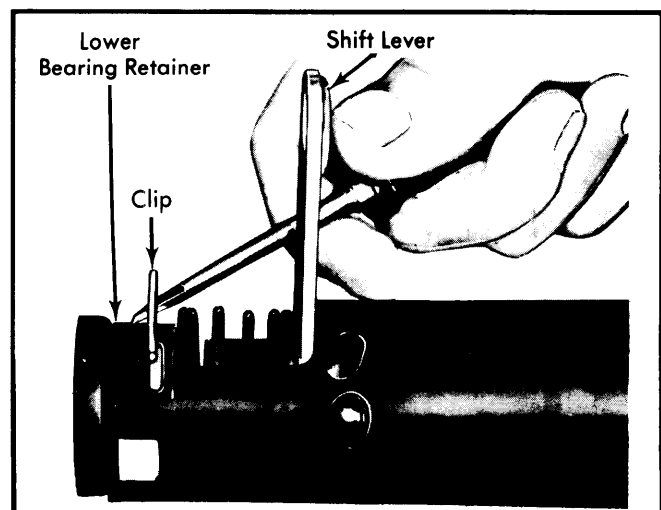

Fig. 3 Removing Lower Bearing Retaining Clip

5) On vehicles with automatic transmission or floorshift, remove lower bearing retainer, bearing adapter assembly, shift tube thrust spring and washer. Lower bearing may be

GENERAL MOTORS (Cont.)

removed from adapter by light pressure on bearing outer race. Slide out shift tube assembly.

6) On vehicles with manual transmission and column shift, remove lower bearing adapter, bearing and 1st-Reverse shift lever. Lower bearing may be removed from adapter by light pressure on bearing outer race. Remove three screws from bearing at lower end and slide out shift tube assembly.

7) On all models with column shift, remove gearshift housing lower bearing from very end of jacket, while aligning indentations in bearing with projections on jacket.

Reassembly - 1) Apply a thin coat of lithium grease to all friction surfaces. Install sector into directional signal and lock cylinder housing. Install sector in lock cylinder hole over sector shaft with tang end to outside of hole. Press sector over shaft with blunt tool. Install shift lever detent plate onto housing. Insert rack preload spring into housing from bottom side. Long section should be toward handwheel and hook onto edge of housing.

2) Assemble locking bolt onto crossover arm on rack and insert rack and lock bolt assembly into housing from bottom with teeth up (toward handwheel) and toward centerline of column. Align first tooth on sector with last tooth on rack; if aligned properly, block teeth will line up when rack assembly is pushed all the way in.

3) Install thrust cup on bottom hub of housing. Install gearshift housing lower bearing from very end of jacket, while aligning indentations in bearing with projections on jacket.

CAUTION - If bearing is not properly installed, it will not rest on all the stops provided.

4) Install shift lever spring into gearshift lever (or lock tube) housing. Install housing and shroud assemblies onto upper end of mast jacket. Rotate housing to be sure it is seated in bearing. With shift lever housing in place, install directional signal and lock cylinder housing onto jacket. Gearshift housing

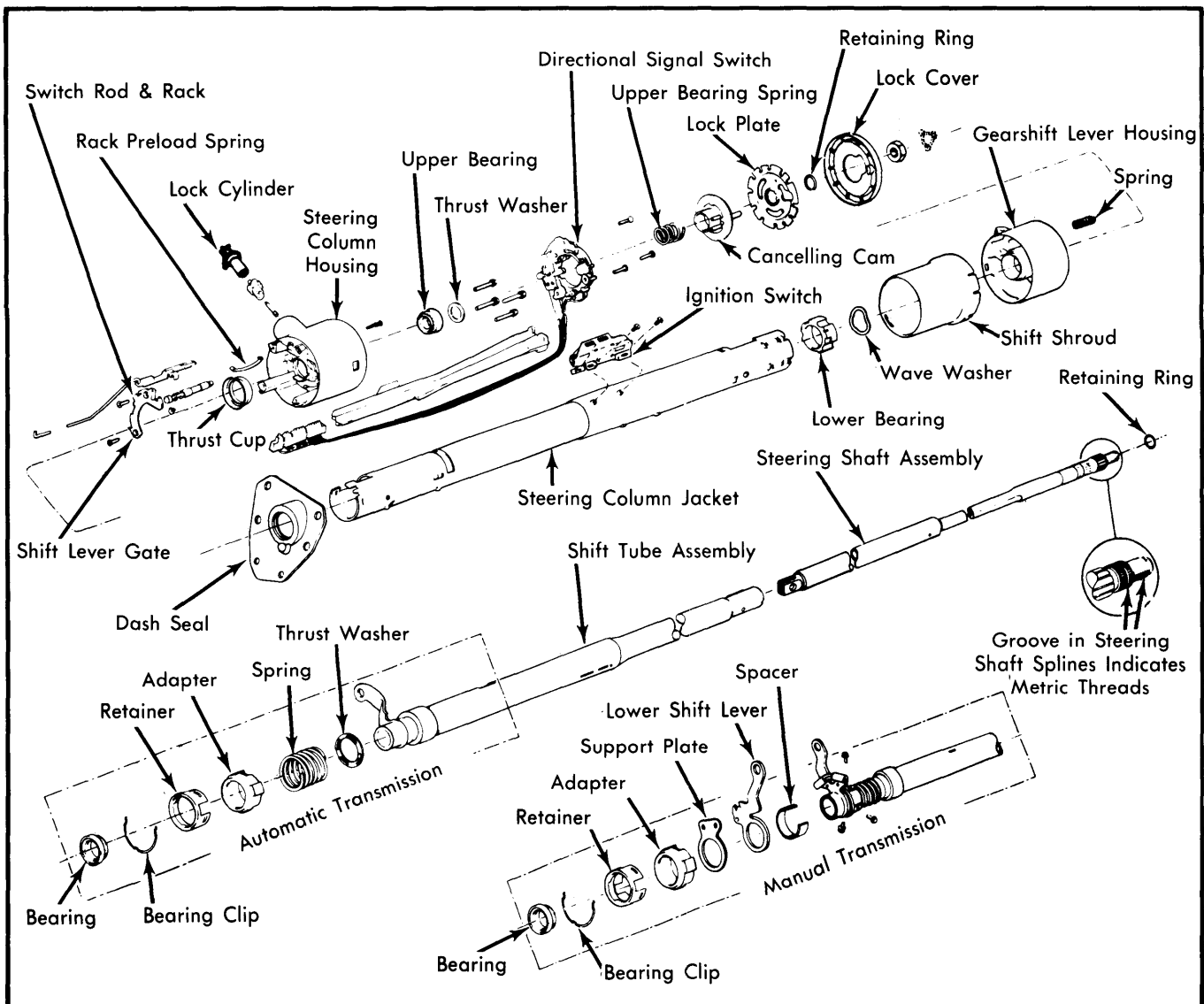

Fig. 4 Exploded View of Steering Column Assembly "C" & "K" Models with Column Shift

Steering Columns

GENERAL MOTORS (Cont.)

should be in "PARK" position and rack pulled downward. Be sure directional signal housing is seated on jacket and install and tighten four screws.

5) Press lower bearing into adapter assembly. Insert shift tube assembly into lower end of jacket and rotate until upper shift tube key slides into housing keyway.

6) On vehicles with automatic transmission or floor shift, assemble spring, lower bearing and adapter assembly into bottom of jacket. Holding adapter in place, install lower bearing reinforcement and retainer clip. Be sure clip snaps into jacket and reinforcement slots.

7) On vehicles with manual transmission and column shift, loosely attach three screws in jacket and shift tube bearing. Assemble 1st-Reverse lever and lower bearing and adapter assembly into bottom of jacket. Holding adapter in place, install bearing reinforcement and retaining clip. Be sure clip snaps into jacket and reinforcement slots. Place a .005" shim between 1st-Reverse lever and lever spacer and turn upper shift tube bearing down until definite drag is felt at 1st-Reverse lever. Tighten attaching screws and remove shim.

8) On all models, install neutral or back-up switch. Slide steering shaft into column and install upper bearing thrust washer. Install directional signal switch, lock cylinder assembly and ignition switch. Install shift lever and pin. Remove column from vise. Install dash bracket to column and tighten screws.

"G" & "P" MODELS WITHOUT TILT WHEEL

Disassembly - 1) Remove steering wheel nut and flat washer, then slide steering shaft assembly out of lower end of column. Remove lower bearing spring and clamp from steer-

ing shaft ("G" models) or from steering column ("P" models). Remove back-up lamp switch. Drive out shift lever pin (except floor shift models) and remove shift lever.

2) Remove directional switch cancelling cam and switch lever. Remove column wiring harness cover. Remove directional signal switch screws. Rotate directional signal switch housing counterclockwise and remove housing from column. Remove plastic thrust washer assembly and then remove shift lever housing (or extension housing if floor shift) from column.

NOTE - Housing and switch cannot be fully removed from column until shift lever housing is removed.

3) Separate directional signal switch, switch control support assembly, directional signal housing and shift lever housing (or extension housing) assemblies. Press steering shaft upper bearing out of switch contact support. Remove shift lever housing (or extension housing) seat and bushing from upper end of column. Remove bolt and screws from adjusting ring clamp and remove clamp, adjusting ring, and lower bearing. Press lower bearing out of adjusting ring.

4) On three speed columns, remove 1st-Reverse shift lever and lever spacer. On automatic transmission columns, remove selector plate clamping ring screws. On all models, place column upright on floor, supporting it with 2 pieces of wood. Place a block of wood on upper end of shift tube. Press down on shift lever with foot while tapping on wood block to withdraw tube from column jacket. If removal is difficult, use a suitable press.

5) Remove felt seal from shift tube. Remove firewall clamp, floor pan seal and dash seals from jacket. Inspect parts for excessive wear, rust or corrosion.

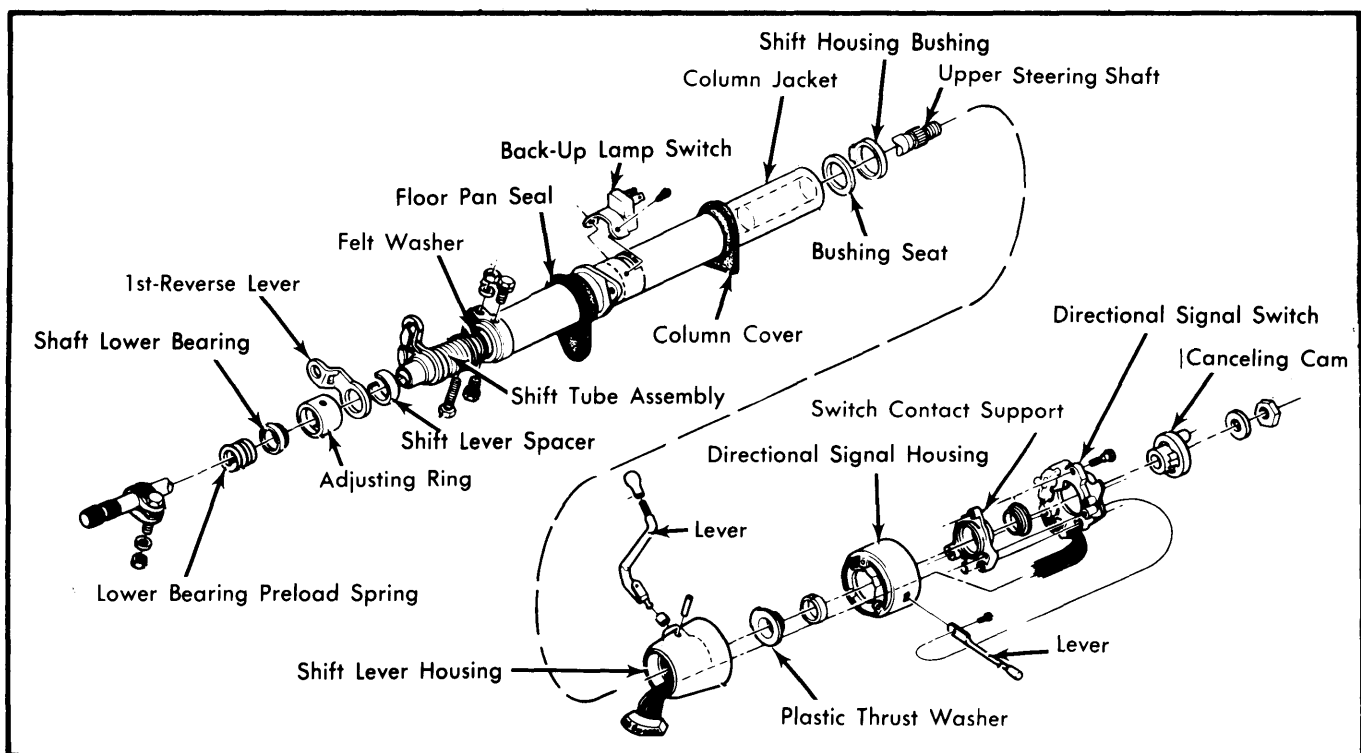

Fig. 5 Exploded View of Steering Column Assembly for "G" & "P" Models

GENERAL MOTORS (Cont.)

Reassembly — 1) When lubrication is called for, use lithium soap grease. Install dash panel seal, floor pan and firewall clamps over end of column. Lubricate all bearing surfaces on shift tube. Place felt seal onto shift tube (next to spring) and place shift tube in jacket.

2) On three speed column shift models, temporarily install spacer, 1st-Reverse shift lever and lower adjusting ring. Place a block of wood on top of adjusting ring and tap until shift tube bottoms. Remove adjusting ring, shift lever, and spacer. On automatic transmission columns, align 3 holes in selector plate with 3 holes in jacket. Shift tube spring retainer must be bottomed against jacket stops. Position clamping ring and install 3 screws.

3) On three speed columns, lubricate and install spacer and 1st-Reverse lever (tang of lever towards top of column). On all columns, install lower bearing in adjusting ring, then install adjusting ring, clamp, and screws. Install shift lever housing (or extension housing) seat and bushing to upper end of housing.

4) Thread directional signal switch wiring harness through switch and shift lever (or extension) housings. Lubricate inner diameter of shift (extension) housing and install onto upper end of column. Install switch housing plastic washer assembly. Press upper bearing into switch contact support.

5) Install directional signal switch housing, contact support, bearing, and switch. Tighten screws. Install column wiring harness cover and back-up lamp switch. Install directional signal and gearshift levers.

6) Loosely install lower bearing preload spring and clamp. Slide steering shaft assembly through column assembly. Install directional signal canceling cam, steering shaft nut and lock washer.

"C" & "K" MODELS WITH TILT WHEEL

Disassembly — 1) Remove four dash panel bracket-to-column screws and lay bracket in safe place to prevent damage to mounting capsules. Place column in a vise using both weld nuts of set "A" and "B" as shown in Fig. 2.

CAUTION — Do not place column in vise by clamping onto only one nut or by clamping on to sides of nut not indicated by arrows.

2) Remove directional signal switch, lock cylinder, and ignition switch. Remove tilt release lever, then drive out shift lever pivot pin and remove shift lever and housing. Remove three directional signal housing screws and remove housing.

3) Install tilt release lever and place column in full up position. Remove tilt lever spring retainer by using a phillips screwdriver which just fits into slot opening. Insert screwdriver into slot, press in approximately $\frac{3}{8}$ ", then rotate $\frac{1}{8}$ turn counterclockwise until retainer ears align with grooves in housing, then remove retainer, spring, and guide. See Fig. 6.

4) Remove pot joint-to-steering shaft clamp bolt, then remove intermediate shaft and pot joint assembly. Push upper steering shaft in enough to remove steering shaft upper bearing inner race and seat. Pry off lower bearing retainer clip, then remove bearing reinforcement, bearing, and bearing adapter

assembly from lower end of mast jacket. Remove upper bearing housing pivot pins using special tool (J-21854-1).

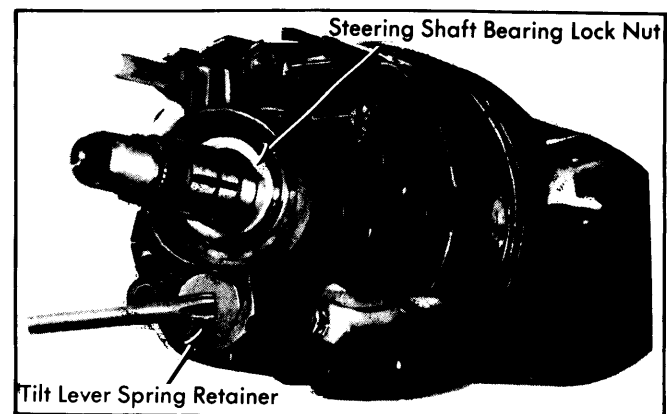

Fig. 6 Removing Tilt Lever Spring Retainer

5) With tilt release lever installed, disengage lock shoes. Remove bearing housing by pulling upward to extend rack full down, then move housing to left to disengage ignition switch race from actuator rod. Remove steering shaft assembly from upper end of column. Remove centering spheres and anti-lash spring to disassemble steering shaft.

6) Remove transmission indicator wire, if equipped. Remove steering shaft bearing housing support-to-gearshift housing screws, then remove bearing housing support. Remove ignition switch actuator rod. Use a screwdriver to remove shift tube retaining ring, then remove thrust washer.

7) Install a puller (J-23072) to lock plate, then turn center screw of tool clockwise to force shift tube from housing. Remove shift tube (transmission control lock tube on floor shift models) from lower end of mast jacket, then remove tool from lock plate.

CAUTION — Guide lower end of shift tube through slotted opening in mast jacket. If tube is allowed to interfere with jacket, damage may result.

8) Remove housing support lock plate by sliding out of jacket notches, then tipping it down toward housing hub at 12 o'clock position and sliding it under jacket opening. Remove wave washer. Remove shift lever housing from mast jacket (column shift models) or transmission control lock tube housing (floor shift models). Wind up shift lever spring with pliers and pull out. Remove spring plunger on floor shift models.

9) On all columns disassemble bearing housing as follows: Remove tilt lever opening shield, then remove lock bolt spring retaining screw and move spring clockwise to remove it from bolt. Remove sector drive shaft snap ring, then use a small punch to lightly tap drive shaft from sector. Remove drive shaft, sector and lock bolt. Remove rack and rack spring.

10) Use a punch to remove tilt release lever pin. Remove lever and release lever spring. Hold lock shoes inward and wedge a block between top of shoes (over slots) and bearing housing to relieve load on release lever. Remove lock shoe retaining pin using a punch, then remove lock shoes and springs. Remove bearings from housing only if replacement is necessary.

Steering Columns

GENERAL MOTORS (Cont.)

Reassembly — 1) Apply a thin coat of lithium grease or equivalent to all friction surfaces. If bearing housing was not disassembled, proceed to step 4). To reassemble bearing housing, press bearings into housing (if removed) using a suitable size socket being careful not to damage housing or bearings. Install lock shoe springs, lock shoes, and shoe pin in housing.

NOTE — Use a .180" diameter rod to line up shoes for pin installation.

2) Install shoe release lever, spring and pin. If necessary to relieve load on release lever, hold shoes inward and wedge a block between top of shoes (over slots) and bearing housing. Install sector drive shaft into housing and lightly tap sector onto shaft far enough to allow installation of snap ring. Install snap ring.

3) Install lock bolt and engage it with sector cam surface. Install rack and spring while noting that the block tooth on rack should engage block tooth on sector. Install external tilt release lever. Install lock bolt spring and retaining screw and tighten.

4) Wind up shift lever spring with pliers and push into housing. Install plunger on floor shift models. Slide gearshift lever housing onto mast jacket. On all models, install bearing support lock plate wave washer. Install lock plate and work it into notches by tipping plate toward hub a 12 o'clock position and sliding under jacket opening. Slide lock plate into notches in jacket.

5) Install shift tube into lower end of mast jacket, then align keyway of tube with key in shift lever housing. Install wobble

plate end of special tool (J-23073) into upper end of shift tube (far enough to reach enlarged portion of tube). Install adapter over end of tool and seat against lock plate. Install nut on end of tool and pull shift tube into housing.

CAUTION — Do not push or tap on end of shift tube and make sure shift tube lever is aligned with slotted opening at lower end of mast jacket or damage may result.

6) Pull shift lever housing up far enough to compress wave washer, then install bearing support thrust washer and retaining ring. Install bearing support while ensuring "V" in support is in line with "V" in jacket. Install attaching screws through support and into lock plate, then tighten. Align lower bearing adapter with notches in jacket and push adapter into lower end of mast jacket. Install lower bearing, bearing reinforcement and retaining clip.

NOTE — Clip must be aligned with slots in reinforcement, jacket and adapter.

7) Install centering spheres and anti-lash spring into upper shaft. Install lower shaft from same side of spheres that spring ends protrude. Install steering shaft assembly into shift tube from upper end and carefully guide shaft through shift tube and bearing.

8) Install ignition switch actuator rod through shift lever housing and insert into slot in bearing support. Extend rack downward from bearing housing, then assemble bearing housing over steering shaft and engage rack over end of actuator rod. Install tilt release lever, then hold lock shoes in disengaged position and position bearing housing over steering shaft until pivot pin holes line up. Install pivot pins.

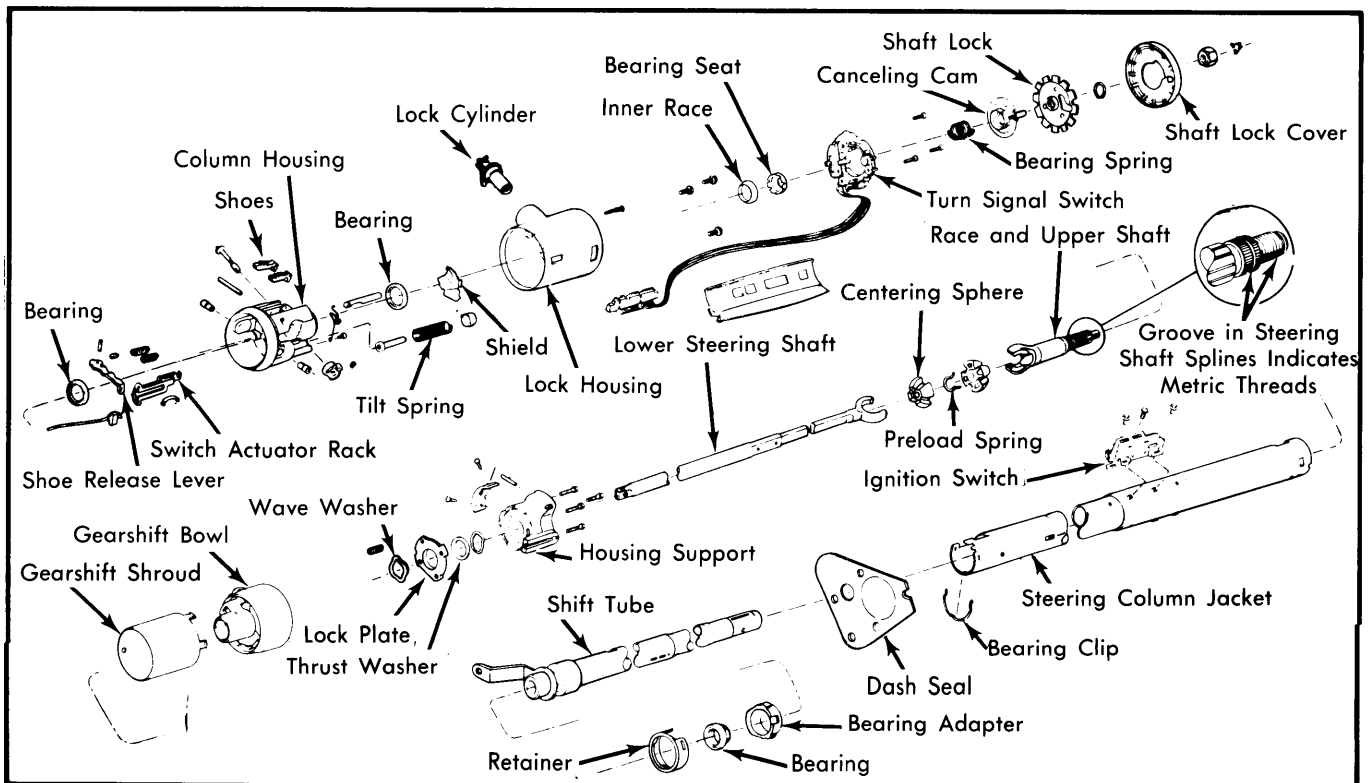

Fig. 7 Exploded View Of Tilt Wheel Steering Column "C" & "K" Models with Column Shift

GENERAL MOTORS (Cont.)

9) Place bearing housing in full up position, then install tilt lever spring guide, spring and spring retainer. Using a phillips screwdriver, push retainer in and turn clockwise to engage in housing. Install upper bearing inner race and race seat, then install tilt lever opening shield. Remove tilt release lever, then install directional signal housing and tighten screws.

10) Install tilt release lever and shift lever, then drive shift lever pin in. Install lock cylinder, directional signal switch, and ignition switch. Install intermediate shaft assembly to upper shaft after aligning groove across upper end of pot joint with flat on steering shaft. Install and tighten clamp while noting that clamp bolt must pass through shaft undercut.

11) Install neutral safety switch or back-up switch. Install dash panel bracket-to-column attaching screws and tighten. The slotted openings in bracket must face upper end of steering column.

"G" & "P" MODELS WITH TILT WHEEL

Disassembly - 1) Place column in vise using suitable holding fixture (J-22573). Remove directional signal switch. Remove lower steering shaft and pot joint assembly. Remove lower bearing and adapter assembly from column, then press bearing out from adapter. If column shift model, remove shift lever pivot pin and shift lever.

2) Install tilt release lever and place column in full up position. Remove tilt lever spring and retainer using a screwdriver that just fits into slot opening. Insert screwdriver into slot, push in approximately $\frac{3}{16}$ " , then rotate clockwise approximately $\frac{1}{8}$ turn until retainer ears align with grooves in housing and remove retainer and spring.

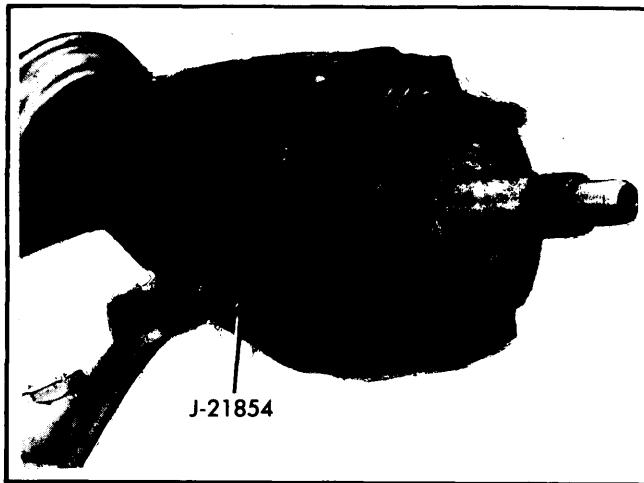

Fig. 8 Removing Bearing Housing Pivot Pins

3) Remove steering shaft bearing lock nut using suitable socket (J-22599). Remove upper bearing race seat and race. Remove two bearing housing pivot pins using suitable tool (J-21854). See Fig. 8.

4) Pull up on tilt release lever (to disengage lock shoes) and remove bearing housing. If it is necessary to disassemble bearing housing, proceed as follows: Press upper and lower bearings out of housing. Using suitable puller (J-5822) and slide hammer, pull bearing races from housing. Remove tilt release lever. Drive out shoe release lever pivot pin using a

punch. Remove lever spring and remove wedge. Drive out lock shoe retaining pin with a punch and remove shoes and shoe springs. See Fig. 9.

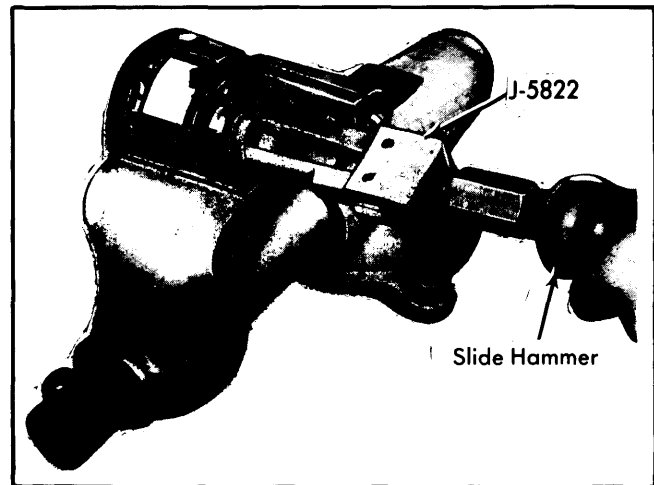

Fig. 9 Using a Puller to Remove Bearing Race

5) Remove steering shaft assembly through upper end of column. If it is necessary to disassemble shaft assembly, proceed as follows: Turn upper shaft 90° to lower shaft and slide upper shaft and centering spheres from lower shaft. Rotate centering spheres 90° and remove centering spheres and preload spring from upper shaft.

6) Remove four bearing housing support screws and remove support. If shift tube index plate (column shift only) must be removed, remove two retaining screws and remove plate. Remove shift tube retaining ring with screwdriver. Remove thrust washer. Remove neutral start switch or back-up lamp switch retaining screws and remove switch. See Fig. 10.

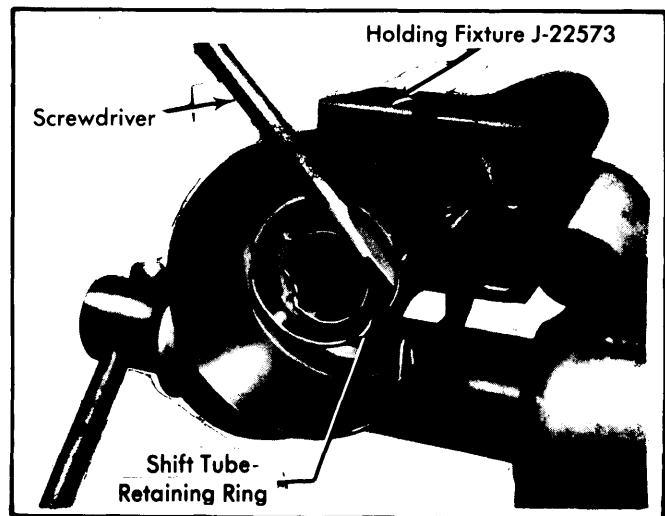

Fig. 10 Removing Shift Tube Retaining Ring

7) Rework a shift tube removing tool (J-22551) by removing $\frac{1}{2}$ " from pilot end of tool as shown in Fig. 11. Remove shift tube assembly using reworked tool as follows: Insert hooked end of tool into notch in shift tube just below shift lever housing key. Pilot sleeve over threaded end of tool and into upper

Steering Columns

GENERAL MOTORS (Cont.)

end of shift tube. Force shift tube out of housing by turning nut onto the tool. If shift tube is not completely free when nut is bottomed on its threads, complete removal by hand. On column shift models, guide lower shift lever through slotted opening in column to prevent damage to tube or column.

CAUTION — Do not hammer on shift tube during removal.

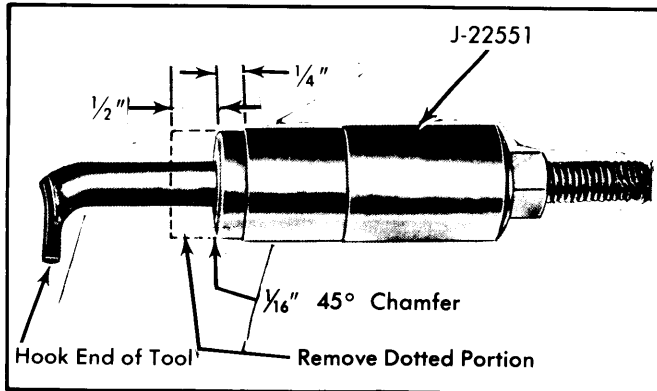

Fig. 11 Reworked Shift Tube Removal Tool

8) On all models, remove lock plate by sliding out of column notches, tipping plate downward toward housing to compress wave washer and then removing wave washer and lock plate. On column shift models, remove shift lever housing and shift lever spring. On all models, remove dash panel seal mounting plate and instrument panel seal from column jacket.

Reassembly — 1) When lubrication is called for, use lithium soap grease. Install dash panel seal, mounting plate and instrument panel seal on column. On column shift models, press a new shift lever spring into shift lever housing. Slide shift lever housing over upper end of column. Place wave washer and lock plate in position. Work lock plate into notches by tipping plate toward housing (compressing wave washer) at open side of column. Lubricate lock plate and upper end of shift tube.

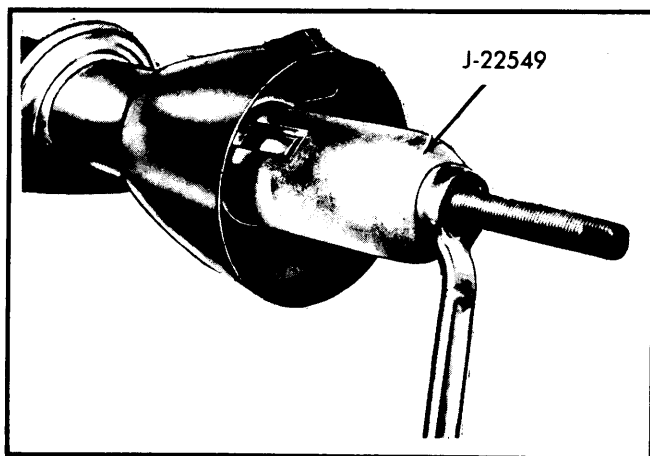

Fig. 12 Installing Shift Pin Tube

2) Carefully install shift tube into lower end of column (make sure foam seal is at lower end of shift tube). Align keyway in tube with key in shift lever housing and complete installation of shift tube using suitable installer tool (J-22549). Shift lever

housing key must bottom in shift tube slot to be fully installed. Remove installer tool from column. Lubricate and push foam seal in flush with column housing. See Fig. 12.

CAUTION — Do not hammer or force tube when installing in column.

3) Pull up on shift lever housing (to compress wave washer) and install thrust washer and retaining ring. Be sure ring is seated in both slots of shift tube. Lubricate inside diameter of bearing housing support and install support, aligning bolt holes in support with bolt holes in lock plate. Install four support screws and tighten.

4) Assemble steering shaft as follows: Lubricate and assemble centering spheres and preload spring. Install spheres into upper (short) shaft and rotate 90°. Install lower shaft 90° to upper shaft and over centering spheres. Slowly straighten shafts while compressing preload spring.

5) Install shaft assembly into housing from upper end. Install lower bearing and adapter, bearing reinforcement, wire clip, pot joint coupling and lower shaft.

6) Assemble bearing housing as follows: Press new upper and lower bearing races into bearing housing. Lubricate and install bearings into races. Place lock shoe springs in position in housing. Install each shoe in place and compress spring until a suitable size straight punch can be used to hold shoes in position. Once shoes are in place, install retaining pin. Install shoe release lever and drive in pivot pin. Install tilt release lever. Lubricate shoes and release lever.

7) Install bearing housing assembly to support. Hold tilt release lever up until shoes have fully engaged support. Lubricate and install bearing housing pivot pins. Press pins in flush with housing. Place housing in full "UP" position and then install tilt spring and retainer (tapered end of spring first). Push into housing approximately $\frac{3}{16}$ " and rotate counterclockwise $\frac{1}{8}$ turn.

8) Lubricate and install upper bearing upper race, race seat and lock nut. Tighten lock nut to remove lash and then further tighten $\frac{1}{16}$ to $\frac{1}{8}$ turn (column must be in straight-ahead position). Remove tilt release lever.

9) Install directional signal switch. Install shift lever and pivot pin if column shift model. Install neutral-start or back-up lamp switch. Remove column from vise.

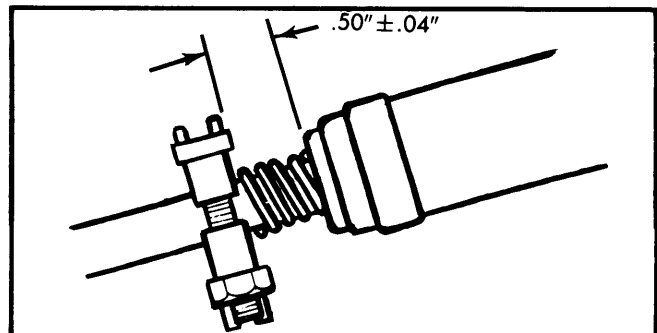

Fig. 13 Steering Column Lower Bearing Adjustment for "G" Models

GENERAL MOTORS (Cont.)

ADJUSTMENTS

LOWER BEARING ADJUSTMENT

"G" & "P" Models - Loosen clamp on steering shaft. Apply 50 lbs. force to steering wheel end of shaft and adjust clamp to obtain clearance of $.50 \pm .04$ " for "G" models and $1.26 \pm .02$ " for "P" models. See Figs. 13 and 14. Tighten clamp bolts to specifications.

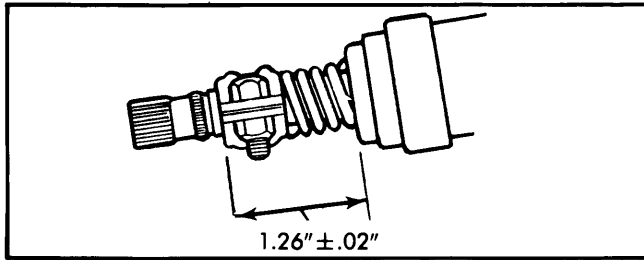

Fig. 14 Steering Column Lower Bearing Adjustment for "P" Models

SHIFTER TUBE ADJUSTMENT ("G" & "P" Models)

Manual Transmissions - Loosen adjusting ring attaching screws and clamp bolt. Rotate adjusting ring to give $.005$ " end play between adjusting ring and 1st-Reverse shift lever. Tighten attaching screws and clamp bolt. See Fig. 15.

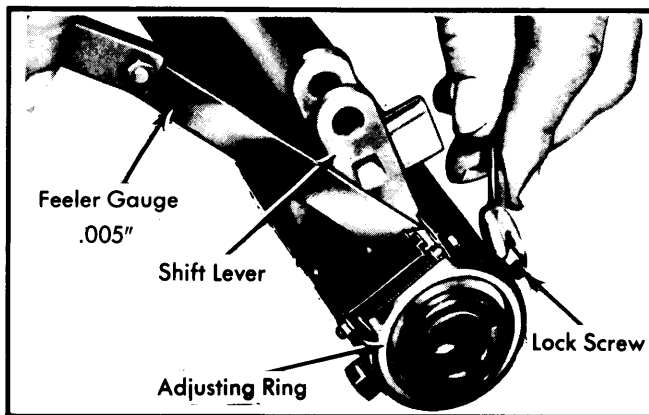

Fig. 15 Shift Tube Adjustment for Manual Transmission "G" & "P" Models

Automatic Transmissions - Place shift tube lever in "N" or "D". Loosen adjusting ring clamp screws and rotate adjusting ring to obtain $.33-.36$ " end play between shift tube lever and adjusting ring. Tighten adjusting ring clamp screws. See Fig. 16.

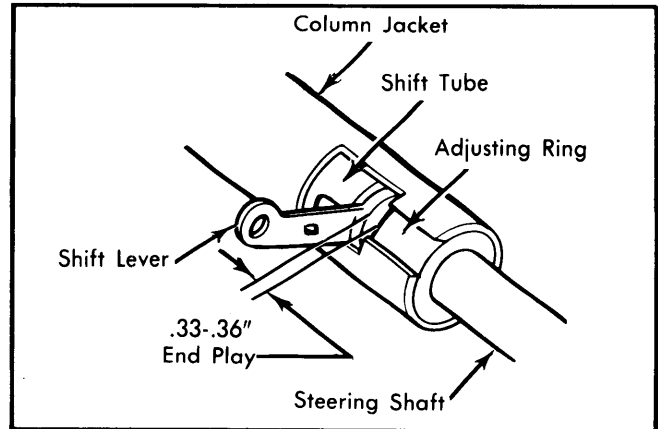

Fig. 16 Shift Tube Adjustment for Automatic Transmission "G" & "P" Models

ADJUSTMENT SPECIFICATIONS

Application	Specification
Lower Bearing Adjustment	
"G" Models	$.50 \pm .04$ "
"P" Models	$1.26 \pm .02$ "
Shift Tube Adjustment	
Automatic Transmission	$.33-.36$ "
Manual Transmission	$.005$ "

TIGHTENING SPECIFICATIONS

Application	Ft. Lbs.
Flexible Coupling Bolt & Studs	
"P" Models	20
All Others	18
Lower Jacket Bearing Clamp	30
Lower Coupling-to-Worm Shaft Clamp	
"P" Models	75
All Others	30
Application	INCH Lbs.
Column-To-Dash Panel	125
Floor Pan Cover Plate	
"P" Models	24
"G" Models	30
Firewall Bracket Clamp	
"G" Models	150
"P" Models	98
All Others	90
Lower Bearing Adjusting Ring Bolt	70
Ignition Switch Screws	35
Column Lock Plate Cover	20
Turn Signal Housing	45
Lock Bolt Spring Screw (Tilt Wheel)	35
Bearing Housing Support Screw (Tilt Wheel)	60