

Wheel Alignment

CHRYSLER CORP.

ALL MODELS W/LEAF SPRINGS

CASTER

Caster should be checked after camber and steering axis inclination have been checked. Caster adjustment is accomplished by inserting wedge between spring and axle. To increase caster, insert wedge with thick portion toward rear of vehicle. To decrease caster, insert wedge with thick portion of wedge toward front of vehicle.

CAMBER

No adjustment is provided for camber. Camber is preset at factory, and if not within limits, axle or steering knuckle is bent and should be replaced.

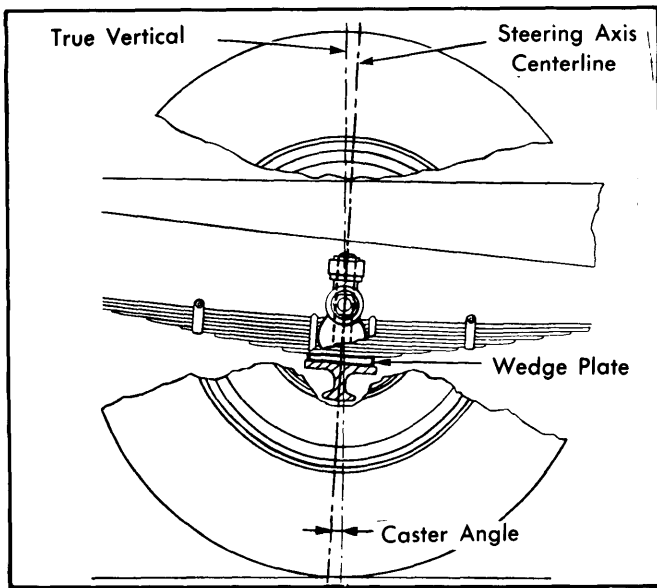

Fig. 1 Caster Angle Adjustment

ALL MODELS W/COIL SPRINGS

CASTER

AD, AW, D, PD, PW and W Models – 1) Caster is controlled by eccentric bolts which mount upper control arm-to-frame. To obtain positive caster, loosen forward eccentric bolt lock nut and turn eccentric bolt to force front part of control arm outward, or loosen rear eccentric bolt lock nut and turn eccentric to pull rear of control arm inward.

2) To obtain negative caster, loosen eccentric bolt lock nut and turn forward eccentric bolt to pull front part of control arm inward, or loosen rear eccentric bolt lock nut and turn eccentric bolt to force rear of control arm outward. Tighten eccentric bolt lock nuts to 70 ft. lbs.

CAMBER

AD, AW, D, PD, PW, and W Models – 1) Camber is controlled by eccentric bolts which mount upper control arm-to-frame. To increase camber, loosen eccentric bolt lock nuts and turn both eccentric bolts an equal amount to force upper control arm outward.

2) To decrease camber, turn both eccentric bolts an equal amount to pull upper control arm inward. Tighten eccentric bolt lock nuts to 70 Lbs.

NOTE – Turning both eccentric bolts an equal amount will change only camber without affecting caster.

CASTER & CAMBER

B, CB, MB, and PB Models – 1) Caster and camber is controlled by upper control arm pivot bar. Bar is bolted to frame mounted bracket through slotted holes. Alignment is made by loosening one bolt at a time and prying pivot bar into position. Make alignment adjustment for camber by moving both ends of pivot bar in or out in exactly equal amounts.

2) Adjustment for caster is made by moving each end of bar in exactly equal amounts in opposite directions. Increase positive caster by moving front of pivot bar away from engine and rear of bar toward engine an equal amount. Tighten retaining bolts to 195 ft. lbs.

NOTE – Do not attempt to make adjustments by loosening both bolts at the same time. Caster should be held as nearly equal as possible on both wheels.

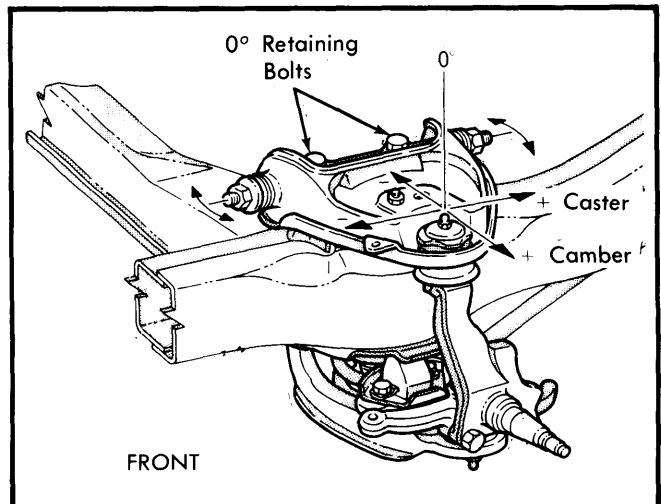

Fig. 2 Wheel Alignment Adjustments (B, CB, MB and PB Models)

TURNING ANGLE ADJUSTMENT (4-WD MODELS ONLY)

1) The turning angle stop screws are located on back side of steering knuckle, just above axle shaft centerline. To adjust, loosen stop screw lock nut.

2) Using full-floating turn table under each wheel, adjust turning angle to specifications by adjusting stop screw IN to increase and OUT to decrease turning angle.

Turning Angle Adjustment (4-WD Models Only)		
Application	Left Wheel	Right Wheel
W150	37°	27°
W250	35°	①29°
W350/450	34°	29°
D150/450	33°	33°

① – If equipped with 8.75 x 16.5" tires, turning angle is 26°. If equipped with 9.50 x 16.5" tires, turning angle is 24°.