

GENERAL MOTORS SLIDING CALIPER DISCS

Chevrolet GMC

NOTE — Bendix sliding caliper disc brakes are used on all diesel engine models and all models equipped with Bendix Hydro-boost. Bendix sliding caliper disc brakes are also used on models equipped with four-wheel disc brakes. All other models use Delco floating caliper disc brakes. See appropriate article in this section.

DESCRIPTION

Bendix sliding caliper disc brakes use a single piston caliper. Front calipers are attached to a mount integral with the steering knuckle. Rear calipers are mounted to an adapter bolted to the drive axle. When brakes are applied, hydraulic pressure is passed to caliper piston. This force is transmitted to inner brake pad against inner rotor braking surface. Pressure then moves caliper inward, thus forcing outer disc pads against outer braking surface. When brakes are released, pressure is removed from caliper cylinder and rotor runout moves piston back into caliper cylinder to maintain sufficient rotor-to-pad clearance.

ADJUSTMENT & SERVICING

DISC PAD ADJUSTMENT

Pad wear is automatically compensated for by piston moving outward in cylinder bore; therefore, no disc pad adjustment in service is required. Inspect condition of disc pads whenever wheels are removed. If any pad is worn to within $\frac{1}{32}$ " of rivet heads, replace complete pad set.

PARKING BRAKE

See *Parking Brake Adjustment in General Motors Single Anchor Brake System in this Section.*

BLEEDING SYSTEM

See *Hydraulic Brake Bleeding in this Section.*

REMOVAL & INSTALLATION

DISC BRAKE PADS

Removal — 1) To prevent master cylinder overflow when caliper is depressed, remove two-thirds of the brake fluid from master cylinder. Raise vehicle and remove wheel. Place a large "C" clamp on caliper and tighten clamp to bottom piston in cylinder bore. Remove clamp.

2) Remove key retaining screw, then using a brass rod and a light hammer, drive out caliper support key and caliper support spring. Remove caliper by pushing down against mount and rotating upward and away from mount.

CAUTION — Support caliper with wire. DO NOT let caliper hang with weight on brake hose.

3) Remove inner disc pad and shoe clip from caliper. Remove outer disc pad from caliper. It may be necessary to tap pad to loosen it in caliper housing.

Installation — 1) Lubricate caliper and mount sliding surfaces with silicone lubricant. Install new anti-rattle clip in mount. Place lower end of inner pad into mount and against anti-rattle clip, then slide upper end of pad into position. Be sure clip is still in correct position.

2) With caliper piston fully bottomed in cylinder bore, position outer pad on caliper and press tabs into place. If pad cannot be properly positioned by hand, use a large "C" clamp, taking care not to mar lining.

3) With disc pads installed, lift caliper and rest bottom edge of outer pad on outer edge of rotor and ensure there is no clearance between bottom tab of outer pad and caliper abutment. Outer pad should be tight in caliper housing.

4) Position caliper on mounting surface. Place spring over support key and tap into place until key retaining screw can be installed. Tighten screw and replace fluid in master cylinder. Reinstall wheel and lower vehicle.

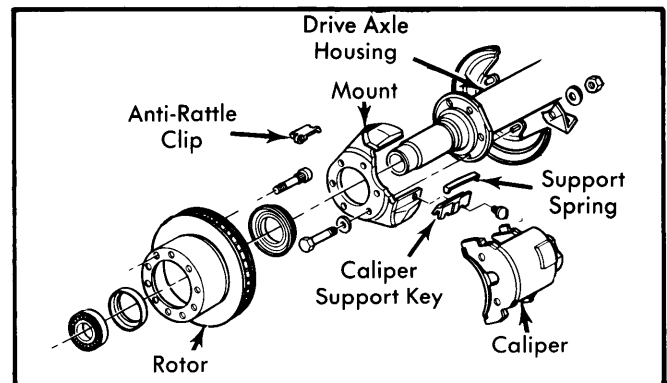

Fig. 1 Rear Sliding Caliper Disc Brake Components

BRAKE CALIPER

Removal & Installation — Caliper removal and installation procedures are the same as those for disc pad replacement, except it will be necessary to disconnect brake hose. Use new copper washers when reconnecting brake hose.

DISC ROTOR

Removal (2-WD Models) — 1) Raise vehicle and position on safety stands. Remove brake caliper without disconnecting brake line as previously outlined.

2) Remove grease cover from end of hub. Remove cotter pin, nut, washer and outer bearing. Remove rotor and hub assembly.

Installation — Install rotor and hub assembly on spindle. Install outer bearing, washer and nut. Adjust wheel bearing. See *Wheel Bearing Adjustment in WHEEL ALIGNMENT Section.*

Removal & Installation (4-WD Models) — Raise and support vehicle on safety stands. Remove wheel and tire. Remove locking hub as outlined in *Locking Hub article in DRIVE AXLE Section.* Remove wheel bearing lock nut, lock ring and adjuster nut. Remove rotor and hub assembly. To install, reverse removal procedures and adjust wheel bearing. See *Wheel Bearing Adjustment in WHEEL ALIGNMENT Section.*

GENERAL MOTORS SLIDING CALIPER DISCS (Cont.)

Removal (Optional Rear Wheel Disc Brakes) — 1) Raise vehicle and position on safety stands. Remove brake caliper without disconnecting brake line as previously outlined.

2) Remove axle shaft flange bolts and remove drive axle. Bend lock tab on bearing lock nut and remove lock nut. Remove lock tab assembly. Remove inner bearing adjusting nut and washer. Remove rotor and hub assembly.

Installation — 1) Install rotor and hub assembly into position on axle housing. Install outer bearing and washer. Make sure tang on washer is aligned with groove in axle housing.

2) Install inner bearing nut and adjust wheel bearings. See *Wheel Bearing Adjustment* in **WHEEL ALIGNMENT** Section.

3) Install drive axle shaft using a new flange gasket. Tighten bolts to 115 Ft. Lbs. Install brake caliper as previously outlined.

3) Remove boot from piston and seal from cylinder bore. Clean caliper housing and piston with denatured alcohol. Check cylinder bore, seal groove, and boot groove for damage and excessive wear. Replace piston if pitted.

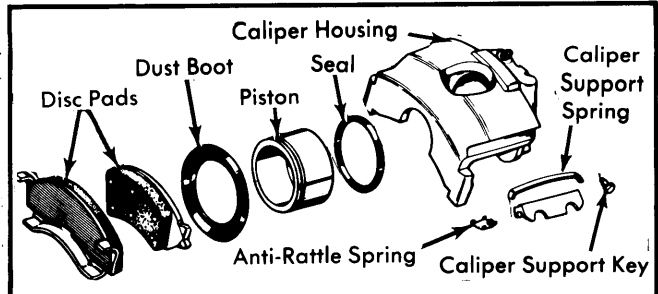

Fig. 3 Exploded View of Sliding Caliper Assembly

OVERHAUL

BRAKE CALIPER

Disassembly — 1) With caliper assembly clean, to prevent contamination, remove plug from caliper inlet port and drain fluid from caliper housing. Place caliper assembly on bench with piston side up and place several shop towels between piston and outer legs of caliper housing.

2) Slowly and carefully apply air pressure to caliper inlet port until piston comes out of caliper housing. If piston is seized, free by tapping lightly on and around end of piston with soft-faced hammer.

CAUTION — Use low air pressure to remove piston. DO NOT place fingers in front of piston when removing, as personal injury may result.

Reassembly — To assemble caliper, soak all parts in suitable brake fluid and reverse disassembly procedure. Use large C-clamp to seat piston in cylinder bore.

DISC ROTOR

Lateral Runout — Adjust wheel bearings until all endplay is eliminated. Attach dial indicator with contact tip of indicator on braking surface approximately one inch from rotor edge. Set indicator to zero and turn rotor through one complete revolution, noting indicator reading.

Parallelism — Check thickness of rotor at four or more points around circumference of rotor. Make all measurements at same distance from edge of rotor. If thickness variation is excessive, refinish or replace rotor as necessary.

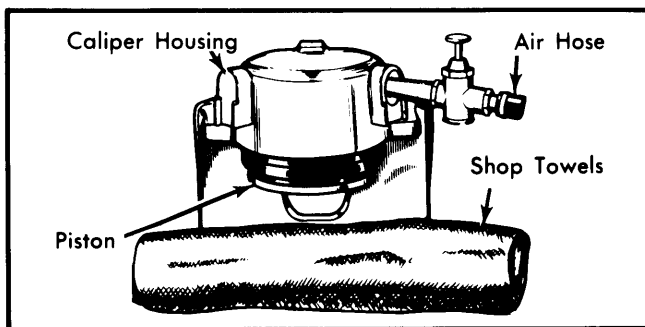

Fig. 2 Using Compressed Air to Remove Caliper Piston

TIGHTENING SPECIFICATIONS

Application	Ft. Lbs.
Brake Line-to-Caliper	32
Support Key Retaining Screw	18
Caliper Mounting Bolts	35
Application	INCH Lbs.
Hydraulic Line-to-Brake Hose	150
Bleeder Valve Screws	60

DISC BRAKE ROTOR SPECIFICATIONS

Application	Disc Diameter	Lateral Runout	Parallelism	Original Thickness	Minimum Refinish Thickness	Discard Thickness
Diesel Engine Models	11.86"	.004"	.0005"	1.280"	1.230"	1.215"
All Others						
Front (Drum Rear)	12.50"	.004"	.0005"	1.530"	1.480"	1.465"
Front (Disc Rear)	14.25"	.004"	.0005"	1.530"	1.480"	1.465"
Rear⓪	13.75"	.004"	.0005"	1.530"	1.480"	1.465"

⓪ — Optional on "P" models and Motor Home Chassis with 11,000 lb. axle.