

## CHRYSLER CORP. SLIDING CALIPER DISCS

Dodge  
Plymouth

### DESCRIPTION

Chrysler vehicles are equipped with single piston, sliding caliper disc brakes. Brake assembly consists of hub and disc assembly, caliper, disc pads, splash shield and adapter. Cooling fins are cast integrally between machined braking surfaces. When the brake pedal is depressed, hydraulic pressure is applied against brake caliper piston. This force is transmitted to inboard brake pad and inner surface of rotor. As force increases against inboard side, caliper slides inward on machined rotor plate ramps, providing vise-like clamping action on rotor.

### ADJUSTMENT & SERVICING

#### DISC PAD ADJUSTMENT

Pad wear is automatically compensated for by piston moving outward in cylinder bore; therefore, no disc pad adjustment in service is required.

**NOTE** — Inspect condition of disc pads whenever wheels are removed. If any pad shows signs of excessive wear, replace complete disc pad set.

#### BLEEDING SYSTEM

See *Hydraulic Brake Bleeding* in this Section.

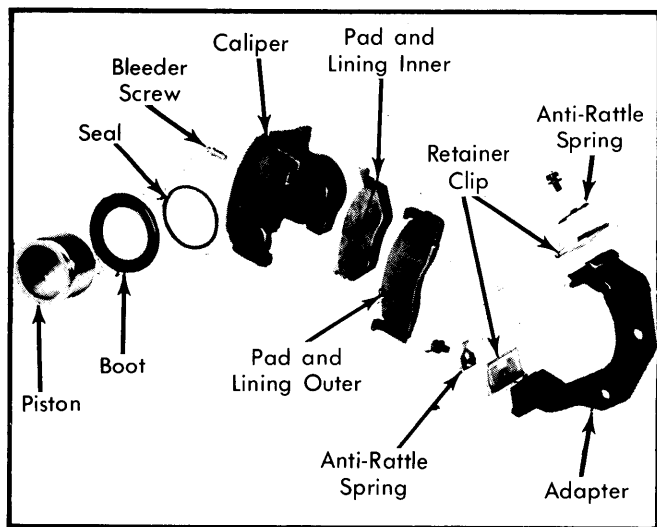

Fig. 1 Exploded View of Chrysler Single Piston Disc Brake Caliper

### REMOVAL & INSTALLATION

#### DISC BRAKE PADS

**Removal (W350/450 & W250 Extra)** — Siphon fluid from master cylinder until cylinder is  $\frac{1}{3}$  full. Raise and support vehicle, and remove wheel. Using a "C" clamp, bottom caliper piston in cylinder bore. Remove clamp. Remove key retaining screws and drive out caliper support key with a brass punch.

Remove caliper support spring and remove caliper from adapter. DO NOT let caliper hang from brake line. Pry outer disc pad from caliper and remove inner disc pad and anti-rattle spring from adapter. If pads are not to be replaced, mark them for reassembly reference.

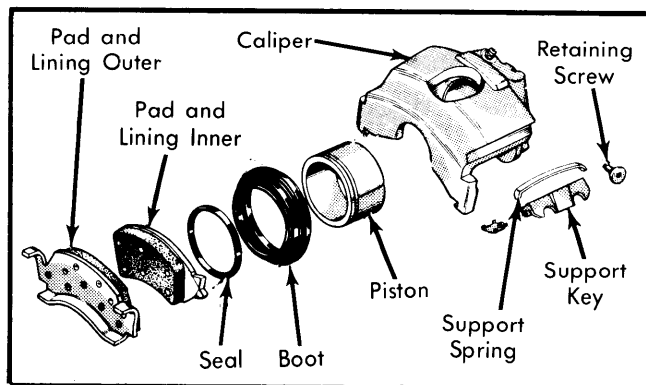

Fig. 2 Exploded View of Bendix Single Piston Disc Brake Caliper

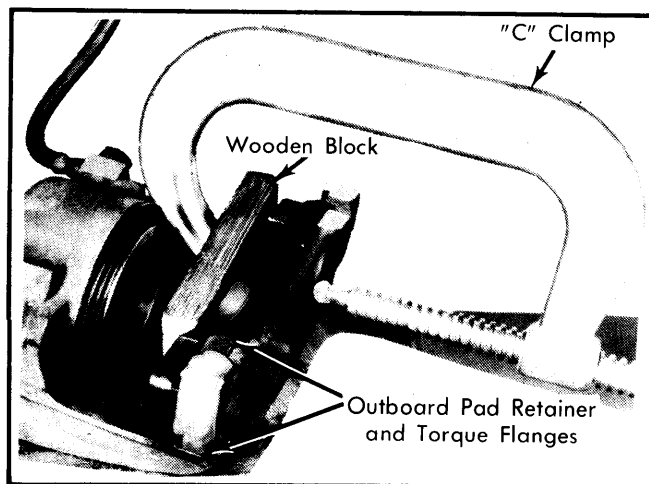

Fig. 3 Installation of Outboard Pad and Liner

**Installation** — Install anti-rattle spring and inner disc pad in adapter, making sure clips remain in position. Place outer disc pad in position in caliper. If disc pad cannot be installed by hand, press into place using a block of wood and a "C" clamp. Position brake caliper on adapter, making sure hose is not twisted. Position spring over caliper key and install between adapter and lower caliper machined surface. Tap into place using a brass punch and hammer. Install retaining screw, making sure boss on screw fits fully into cut-out on key. Install wheel and tire and refill reservoir in master cylinder to within  $\frac{1}{4}$ " of top of reservoir. Pump brake pedal several times and recheck fluid level.

**Removal (All Remaining Models)** — Raise and support vehicle. Remove wheel and tire. Remove caliper retainer and anti-rattle spring assemblies. Carefully lift caliper assembly out and away from rotor. Pry between outer disc pad and fingers of housing to remove outer pad. Support caliper to prevent damage to brake line and remove inner disc pad.

## CHRYSLER CORP. SLIDING CALIPER DISCS (Cont.)

**Installation** — 1) Slowly push piston back into caliper. Care must be taken to ensure reservoir does not overflow while pushing in on piston. Slide outer disc pad into caliper. There should be no free play between disc pad flange and caliper flange. If free play exists, bend disc pad flange until interference fit with caliper is obtained. If necessary, install disc pad using a "C" clamp and block of wood placed across disc pad.

2) Place inner lining on adapter with disc pad flanges aligned with flange ways in adapter. Slide caliper into position in adapter and over disc. Align caliper on adapter, taking care not to pull dust boot away from groove in piston. Install anti-rattle springs and retaining clips and tighten retaining screws to 200 INCH lbs. Pump brake pedal several times until a firm pedal is obtained. Recheck fluid level in master cylinder reservoir.

### BRAKE CALIPER

Brake caliper removal and installation procedures are same as for disc brake pads, except it will be necessary to disconnect hydraulic brake hose at caliper.

### DISC ROTOR

**Removal (2-WD Models)** — 1) Raise vehicle and support on safety stands. Remove brake caliper without disconnecting brake line as previously outlined.

2) Remove grease cover from end of hub. Remove cotter pin, nut lock, nut, thrust washer and outer wheel bearing. Pull rotor and hub off wheel spindle.

**Installation** — Slide rotor and hub into position on spindle. Install outer wheel bearing, thrust washer and nut. Adjust wheel bearing. See *Wheel Bearing Adjustment* in **WHEEL ALIGNMENT** Section. To complete installation, reverse removal procedure.

**Removal (4-WD W/44FBJ Front Axle)** — 1) Raise vehicle and support on safety stands. Remove brake caliper without disconnecting brake line as previously outlined.

2) Using tool C-4170, remove wheel bearing adjusting lock nut. Remove locking ring and wheel bearing adjusting nut.

3) Remove rotor assembly; outer wheel bearing and retainer spring plate will slide out as rotor is removed.

**NOTE** — *Special tools and procedures are required to remove and install inner wheel bearings. See Front Axle Shafts and Bearings in the Dana/Spicer Full-Floating Axle Article in the Drive Axle Section. The following installation procedure is after inner bearings have been installed in rotor hub.*

**Installation** — 1) Mount rotor on spindle. Position inner wheel bearing in place and install inner lock nut using tool C-4170, and tighten to 50 ft. lbs. to seat bearings. Loosen inner lock nut and retighten to 30-40 ft. lbs. while rotating hub. Back off inner lock nut 135 to 150°.

2) Position locking washer by turning nut so that the pin pressed into the lock nut will enter the nearest hole in locking washer. Install and tighten outer lock nut to 50 ft. lbs. Replace caliper assembly.

**Removal (4-WD W/Model 60 Front Axle)** — 1) Raise vehicle and support on safety stands. Remove brake caliper without disconnecting brake line as previously outlined.

2) Remove grease cover from end of hub. Remove snap ring from drive axle. Remove flange bolts and flange from hub.

3) Straighten lock tabs on outer wheel bearing lock ring. Using a suitable socket (DD-1241-JD) remove outer lock nut, lock ring, inner nut and outer wheel bearing. Remove rotor and hub assembly.

**Installation** — Install rotor and hub in position on spindle. Install outer bearing and inner lock nut and adjust wheel bearings. See *Wheel Bearing Adjustment* in **WHEEL ALIGNMENT** Section. Reverse removal procedure for remaining components.

## OVERHAUL

### BRAKE CALIPER

**Disassembly** — 1) Raise vehicle off floor and remove wheel. Remove retainer and anti-rattle spring assemblies. Carefully slide caliper out and away from rotor and support assembly on axle and steering linkage.

2) On vehicles equipped with single piston caliper, carefully depress brake pedal to hydraulically push piston out of bore in caliper. Pedal will fall away when piston has passed bore opening. Prop pedal in any position below first inch of travel to prevent fluid loss.

**CAUTION** — *Under no conditions should air pressure be used to remove piston from bore.*

3) Disconnect brake hose and remove caliper from vehicle. Remove dust boot and piston seal.

**NOTE** — *Use wooden or plastic rod to work seal out of groove in piston bore to prevent damage to cylinder.*

**Inspection** — Clean all parts with alcohol and blow dry with compressed air. Inspect piston bore for scoring or pitting. Light scratches or corrosion can be removed by honing, providing bore diameter is not increased more than .002". Discard used piston seal and boot.

**Reassembly (W350/450 & W250 Extra)** — Lubricate new piston seal with clean brake fluid and install into groove in cylinder bore, working around circumference with fingers until fully seated. Ensure seal is not twisted. Lubricate new piston boot with brake fluid, and install into caliper by working into outer groove. Plug inlet and bleeder screw hole, lubricate piston and with fingers spreading boot, press piston into boot until boot is forced into groove around piston. Remove plug, and carefully push piston down until bottomed.

**Reassembly (All Other Models)** — Lubricate new piston seal with brake fluid and install to groove in bore, working around circumference with fingers until fully seated. Ensure seal is not twisted. Coat new boot with brake fluid (leaving a generous amount inside boot) and install to piston. Install piston into bore, pushing past piston seal until bottomed in bore. Position dust boot in counterbore, and using boot installing tools (C-4890 and C-4171), drive boot into counterbore.

## CHRYSLER CORP. SLIDING CALIPER DISCS (Cont.)

### DISC ROTOR

Mount dial indicator on steering arm with contact tip of indicator against braking surface, approximately 1" from edge of rotor. Temporarily adjust wheel bearings to zero end play. Measure lateral runout on both sides of rotor. Using micrometer, measure thickness at 12 equally spaced locations around rotor, approximately 1" from edge. If rotor is scored, warped, or not within specifications, refinish or replace.

**CAUTION** — If rotor is to be refaced, do not remove more than .015" of material from each side of rotor.

<b>TIGHTENING SPECIFICATIONS</b>	
<b>Application</b>	<b>Ft. Lbs.</b>
Caliper Adapter Bolts	
All with 1/2" Bolts .....	95-125
All with 5/8" Bolts .....	140-180

<b>DISC BRAKE SPECIFICATIONS</b>	
<b>Application</b>	<b>Dimension</b>
Rotor Thickness	
B, D & P150/250, MB250, AD, AW, PD & PW150, (B, CB, MB & PB350 w/3600 lb. Fr. Axle) .....	1.25"
All Other Models .....	1.19"
Thickness Variation	
B, D, PB150/250, MB250, AD, AW, & PD150 B, CB, MB & PB350 .....	.0005"
All Other Models .....	.001"
Lateral Runout	
B, D, & PB150/250, MB250, AD, AW, PD & PW150 B, CB, MB & PB350 .....	.004"
All Other Models .....	.005"