

DELCO-MORAINE TANDEM DIAPHRAGM

Chevrolet
GMC
Jeep

OVERHAUL

DESCRIPTION

Unit is mounted on firewall and connected directly to brake pedal. A combination of vacuum and atmospheric pressure is used to provide power assist. Power cylinder houses power piston assembly, which contains primary and secondary diaphragms, pistons, floating control valve, reaction piston and disc.

REMOVAL & INSTALLATION

POWER BRAKE UNIT

Removal — Without disconnecting hydraulic lines, remove master cylinder from power unit and position to one side. Disconnect vacuum hose from vacuum check valve. Disconnect power brake push rod from brake pedal. Remove nuts mounting power unit to firewall and remove power unit.

CAUTION — Do not bend or kink hydraulic lines, and do not force push rod to the side when disconnecting.

Installation — To install, reverse removal procedures. On Jeep vehicles, use a new bolt to secure push rod to brake pedal.

POWER BRAKE UNIT

Disassembly — 1) Remove pushrod boot, silencer, front housing seal, grommet and vacuum check valve.

2) Scribe a mark on front and rear housing for reassembly reference. Attach front housing to suitable holding fixture (J-22805-01).

3) Place spanner wrench (J-9504) over rear housing studs, press down, and turn counterclockwise to unlock housings. Carefully separate housings.

4) Remove power piston group, power piston return spring, and power piston bearing. Remove piston rod, reaction retainer and power head silencer.

5) Grasp assembly at outside edge of divider and diaphragms. Hold with pushrod down against a hard surface. Use a slight force or impact to dislodge diaphragm retainer.

6) Remove primary diaphragm, primary support plate, secondary power piston bearing, housing divider, secondary support plate and diaphragm and power piston assembly.

Cleaning & Inspection — Clean all plastic, metal and rubber parts in denatured alcohol. Blow out all passages, orifices and valve holes. Air dry all parts. Slight rust on housing may be cleaned with crocus or emery cloth. Do not reinstall any rubber parts with cuts, nicks or distortion. If in doubt, replace the part.

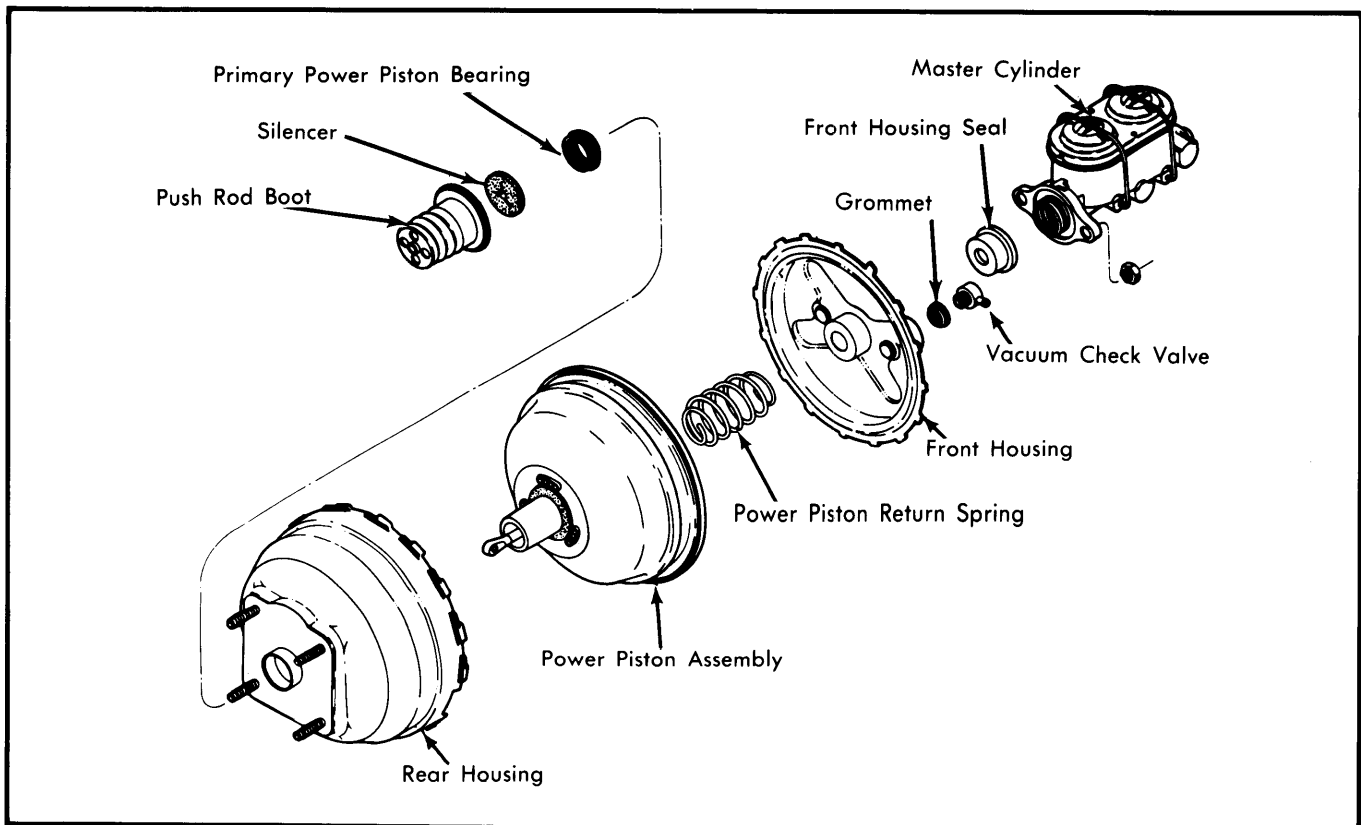

Fig. 1 Exploded View of Delco-Moraine Tandem Power Cylinder

Power Brake Units

DELCO-MORAINE TANDEM DIAPHRAGM (Cont.)

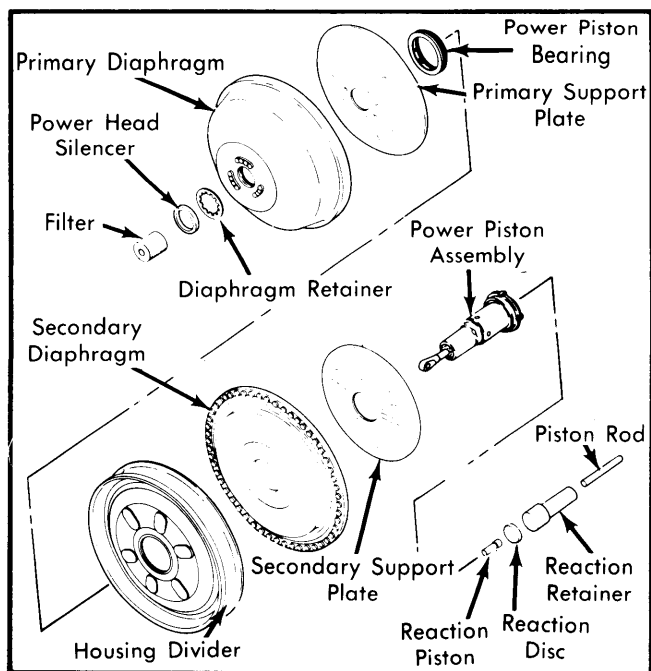

Fig. 2 Exploded View of Delco-Moraine Tandem Power Piston Assembly

NOTE — Prior to installation of rubber, plastic, and metal friction parts, lubricate with suitable silicone lube (5459912).

Reassembly — 1) Place power piston on bench with push rod end up. Install assembly cone J-28458 over push rod end of piston. Lubricate inside diameter of secondary diaphragm with silicon lubricant and fit in secondary support plate.

2) Install secondary diaphragm and support plate over power piston and push down until it bottoms. See Fig. 3. Lubricate inside diameter of secondary power piston bearing and install in housing divider with flat surface of bearing on the same side as 6 raised lugs on divider.

3) Hold divider so that formed over flange faces up. Press divider down over assembly cone and onto power piston to rest against secondary diaphragm. Lubricate inside diameter of primary diaphragm and install in primary support plate. Remove assembly cone from power piston, place primary support plate and diaphragm assembly over power piston and push down until it bottoms.

4) Place diaphragm retainer over power piston and onto diaphragm. Install assembly cone J-28458 over power piston onto diaphragm retainer and strike with hammer until retainer is locked on neck of power piston. Remove assembly cone.

5) Install reaction retainer, piston rod and power head silencer. Place primary power piston bearing in rear housing center hole. Lubricate with silicon lubricant on inner diameter. Attach front housing to holding fixture and place fixture in vise. Install power piston assembly to rear housing.

6) Install power piston return spring over reaction retainer and lower rear housing onto front housing. Align scribe marks and press down on spanner (J-9504), turning clockwise to lock housings. Stake 2 housing tabs into sockets at 2 locations 180° apart.

7) Lubricate inside and outside diameters of grommet and front housing seal. Install seal, grommet, vacuum check valve, silencer and push rod boot.

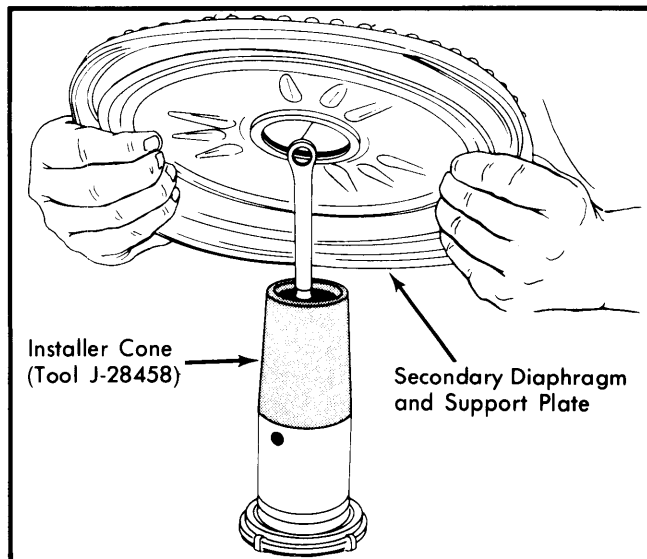

Fig. 3 Installing Secondary Diaphragm and Support Plate

PISTON ROD ADJUSTMENT

NOTE — This adjustment applies to Chevrolet and GMC only. Jeep push rod is not adjustable.

1) Place power unit in padded vise with front housing up. Do not clamp tight. Insert master cylinder piston rod, flat end first, into piston rod retainer. Ensure rod is properly seated. Remove front housing seal to assure no vacuum is in unit.

2) Place suitable gauge (J-22647) over piston rod, in a position which will allow gauge to be moved right or left without contacting studs. Piston rod should contact longer section of gauge. Rod is non-adjustable, and if out of limits, must be replaced with adjustable service rod. With service rod, adjust self-locking screw to meet gauging specifications.

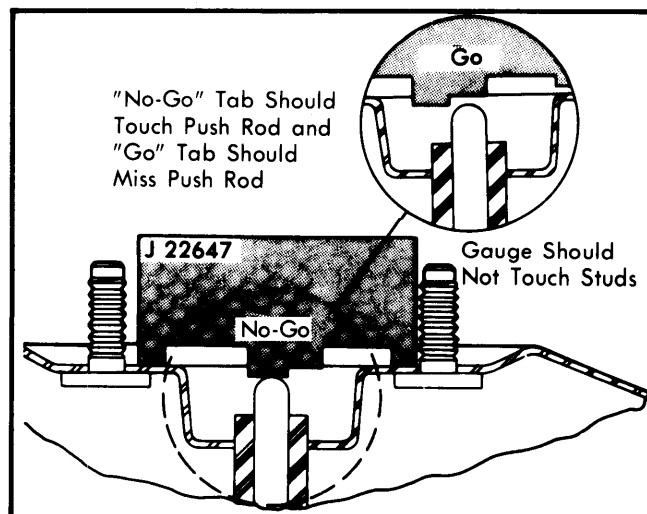

Fig. 4 Gauging Push Rod with Special Gauge (Chevrolet & GMC Models Only)