

BENDIX HYDRO-BOOST

Chevrolet
Dodge
GMC
Plymouth

NOTE — The Bendix Hydro-boost is standard on some models and optional on others. See the BRAKE APPLICATION tables at the beginning of this section.

DESCRIPTION

System utilizes power steering pump fluid pressure to operate booster. Assembly contains an open center spool valve which controls pump pressure magnitude during braking, a lever mechanism to control position of valve, and a boost piston to provide force necessary to operate master cylinder. Unit also has a reserve system which stores sufficient fluid under pressure to provide at least two braking applications in case fluid flow from power steering pump is not available. Brakes can also be applied manually if reserve system is depleted.

OPERATION

RELEASED POSITION (NO BRAKING)

In this position, spool valve return spring holds spool valve open. In open position, spool valve provides unrestricted fluid flow between power steering pump and power steering gear. Fluid pressure is blocked from entering boost pressure chamber by lands on spool valve. As fluid pressure increases with steering demand, it has no effect on boost pressure chamber. Boost pressure chamber is vented through spool valve, to pump return port, and back to power steering pump.

BRAKING POSITION

As brake pedal is depressed, it moves pedal rod and initiates movement of spool valve. This closes fluid return port to pump from boost chamber, and admits fluid into boost chamber from pressure port. Additional valve movement restricts flow between pump and steering gear, causing pump to increase fluid pressure to maintain flow rate to steering gear. As fluid pressure increases in boost chamber, it forces piston forward actuating master cylinder piston, resulting in brake application. If fluid pressure is required for steering while braking, pump pressure will rise and spool valve will shift in an open direction allowing more fluid to flow to steering gear.

RESERVE SYSTEM

1) System consists of a charging valve, accumulator valve, and a spring loaded accumulator. Accumulator is integral with booster unit. System is open to pressure port of booster unit. Charging valve has an orifice and ball check. Fluid from pump passes through orifice in valve, and if pressure exceeds pressure in accumulator, it unseats ball check valve and enters accumulator. Ball check valve prevents reverse flow when accumulator pressure is greater.

2) Accumulator valve is a poppet type valve held closed by pressure stored in accumulator. An actuator on spool valve sleeve opens accumulator valve when a stop with no pump pressure is made that requires use of reserve pressure. Fluid pressure can also enter accumulator from boost chamber through accumulator valve, when boost chamber pressure ex-

ceeds accumulator pressure. A pressure relief valve vents accumulator to pump return port when pressure in accumulator exceeds approximately 1600 psi.

ADJUSTMENT

BRAKE PEDAL

Chevrolet & GMC — 1) Make adjustment in linkage until pedal travel is as specified. Pedal travel is distance pedal moves toward floor from a fully released position. Pump pedal a minimum of 3 times with engine off before making measurement.

2) Specified pedal travel is 3½" on all models except four-wheel disc brake models. Pedal travel is 6" on all four-wheel disc brake models.

NOTE — Pedal adjustment procedure for Chrysler Corp. vehicles was not available from manufacturer.

TESTING

NOTE — Hydro-boost cannot cause noisy brakes, fading brake pedal, or pulling brakes. If one of these conditions exists, other components of brake system are at fault.

PRELIMINARY CHECKS

Make the following checks, and repair if necessary, before performing any test on the Hydro-Boost system:

- Fluid levels in master cylinder & power steering pump.
- Power steering pump drive belt.
- Power steering hoses for leaks or kinks.
- Air in brake fluid or power steering fluid.
- Engine idle speed.
- Steering pump pressure.

NOTE — If problem cannot be found in preliminary steps or tests, check areas of brake system that might cause condition. See *Trouble Shooting in this section for Hydraulic Brake System Trouble Shooting and Hydro-boost Trouble Shooting.*

HYDRO-BOOST FUNCTIONAL TEST

- 1) Make all preliminary checks.
- 2) Place transmission in neutral and stop engine.
- 3) Apply brake several times to deplete accumulator reserve. Hold brake depressed with medium pressure (40 lbs.).
- 4) Start engine. Brake pedal should fall slightly then push back against foot.
- 5) If no action is felt, booster system is not operating properly.

ACCUMULATOR LEAKDOWN TEST

- 1) Start engine, and charge accumulator by either applying brake with 100 lbs. pedal force or turning steering wheel lock to lock.

BENDIX HYDRO-BOOST (Cont.)

2) Turn off engine and wait one hour. There should be one power assisted brake application with engine off.

3) If reserve system will not retain a charge for one hour, but functions normally immediately following charging, or if accumulator can be heard charging and discharging but will not hold a charge, accumulator valves are at fault and power piston/accumulator must be replaced.

NOTE — If Hydro-boost is not functioning, ensure power steering system is operating before replacing Hydro-boost unit.

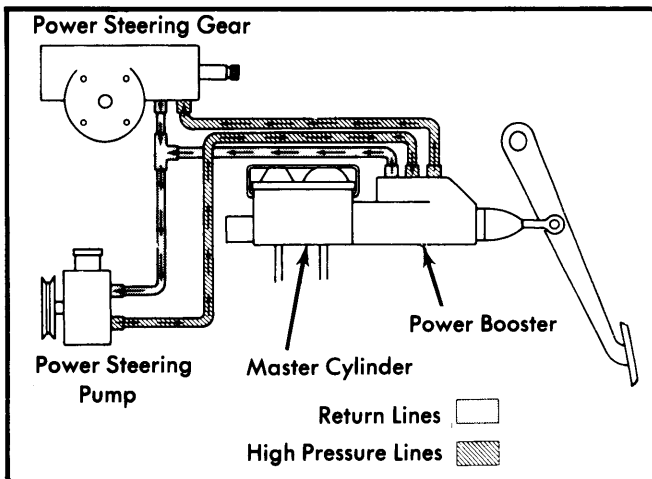

Fig. 1 Hydro-boost Fluid Flow Chart

REMOVAL & INSTALLATION

CHEVROLET & GMC

Removal — 1) Depress and release brake pedal several times to be sure that all pressure is discharged from accumulator prior to disconnecting hoses from booster. Raise Motor Home Chassis on hoist; all others, leave on ground. Clean all dirt from booster at hydraulic line connections and master cylinder. Remove nuts that secure master cylinder to booster and support bracket. Support master cylinder, and cover exposed end with clean cloth.

NOTE — In most cases, it is not necessary to disconnect master cylinder hydraulic lines to remove booster unit.

2) On all models except Motor Home Chassis, remove booster pedal push rod cotter pin and disconnect push rod from brake pedal ("C" and "K" models) or booster bracket pivot lever ("G" and "P" models). Remove booster support bracket ("C" and "K" models) or support braces ("G" and "P" models). Remove booster bracket-to-firewall or support bracket nuts and remove booster assembly.

3) On Motor Home Chassis, remove cotter pin, nut and bolt that secure operating lever to vertical brake rod. Remove the six nuts and bolts that secure booster linkage bracket to front and rear support brackets, and remove booster from vehicle by sliding booster off rear support studs. Remove cotter pin, nut, and bolt that secures operating lever to pedal rod. Remove brake pedal rod lever nut and bolt and then remove lever, sleeve and bushings.

Installation — To install, reverse removal procedure noting the following: Lubricate pedal rod and linkage pivot bolts, pins, sleeves and bushings with suitable lubricant (Delco Brake Lube). Bleed booster/power steering hydraulic system. Check brake pedal and stoplamp switch adjustment.

NOTE — Bleeding Hydro-boost system is a separate procedure from bleeding the hydraulic systems. See Bleeding Hydro-boost Systems in this article.

DODGE & PLYMOUTH

Removal — Depress brake pedal several times to be sure all pressure is released from accumulator. Remove nuts holding master cylinder to booster. Lay master cylinder aside without kinking lines. Disconnect and plug lines from booster fluid ports. Disconnect brake pedal return spring. Remove bolt from push rod to pedal. Remove mounting nuts and booster from vehicle.

Installation — To install, reverse removal procedure. Tighten all nuts and hose connections. Bleed booster/power steering system. Check brake pedal and stop lamp switch adjustment.

NOTE — Bleeding Hydro-boost system is a separate procedure from bleeding the hydraulic systems. See Bleeding Hydro-boost Systems in this article.

BLEEDING

HYDRO-BOOST SYSTEM

NOTE — If power steering fluid has foamed due to low fluid level, it will be necessary to park vehicle for approximately one hour (reservoir cap loose) so that foam can dissipate.

Chevrolet & GMC — 1) Fill reservoir with suitable power steering fluid and leave undisturbed for at least 2 minutes. Start engine and run momentarily. Add fluid if necessary. Repeat until fluid level remains constant after running engine. Raise vehicle so front end is off ground. Turn steering wheel right and left, lightly contacting stops. Add fluid if necessary.

2) Start engine and depress brake pedal several times while turning steering wheel from stop to stop. Turn engine off and depress brake pedal several times to deplete accumulator pressure. Add fluid if necessary.

3) If fluid is foamy, or has air in it, let vehicle stand several minutes, then repeat steps 1) and 2). The presence of air in the system will cause fluid level to rise with engine off. Continue to bleed system until all air is expelled.

Dodge & Plymouth — 1) Check power steering pump reservoir and fill with power steering fluid (MOPAR Power Steering Fluid). Allow fluid to remain undisturbed for 2 minutes. Leave reservoir cap off during operation.

2) Start engine and run for ten seconds. Check fluid level and add fluid if necessary. Repeat procedure until fluid level remains constant. Raise front of vehicle and allow tires to clear floor. Start engine and run at 1500 RPM. Apply and release

Power Brake Units

BENDIX HYDRO-BOOST (Cont.)

brakes several times, at the same time turn wheels back and forth, lock to lock. Turn off engine and check fluid level. Add fluid if necessary.

3) Lower vehicle. Start engine and run at 1500 RPM. Apply and release brake pedal several times, at the same time turn front wheels back and forth, lock to lock. Turn off engine and check fluid level. Add fluid if necessary. If fluid level is low, repeat bleeding procedure. Place cover on reservoir.

BLEEDING BRAKE CYLINDERS

See *Hydraulic Brake Bleeding in this Section.*

OVERHAUL

Disassembly — 1) Secure unit in vise (bracket end up) and use chisel to cut bracket nut that secures linkage bracket to power section. Cut nut at slot in threaded section to prevent damage to threads. Remove linkage bracket from unit.

2) Remove pedal rod boot (if equipped) and place rod retainer shearing tool (see tool chart for number) over rod. Place a punch through pedal rod from lower side of tool and push punch on through to rest on higher side of tool. Lift up on punch to shear pedal rod retainer. Remove pedal rod.

3) Remove remnants of rubber grommet from groove near end of pedal rod and from groove inside input rod end. With small

screwdriver, pry plastic guide out of output push rod retainer. Disengage tabs of spring retainer from ledge inside opening near master cylinder mounting flange of booster. Remove retainer, piston return spring and output rod from opening.

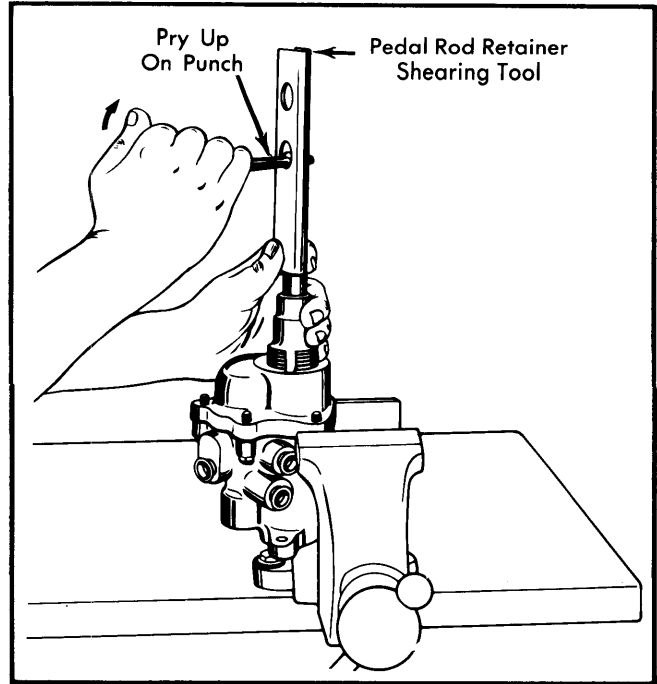

Fig. 2 Procedure for Removing Booster Pedal Rod

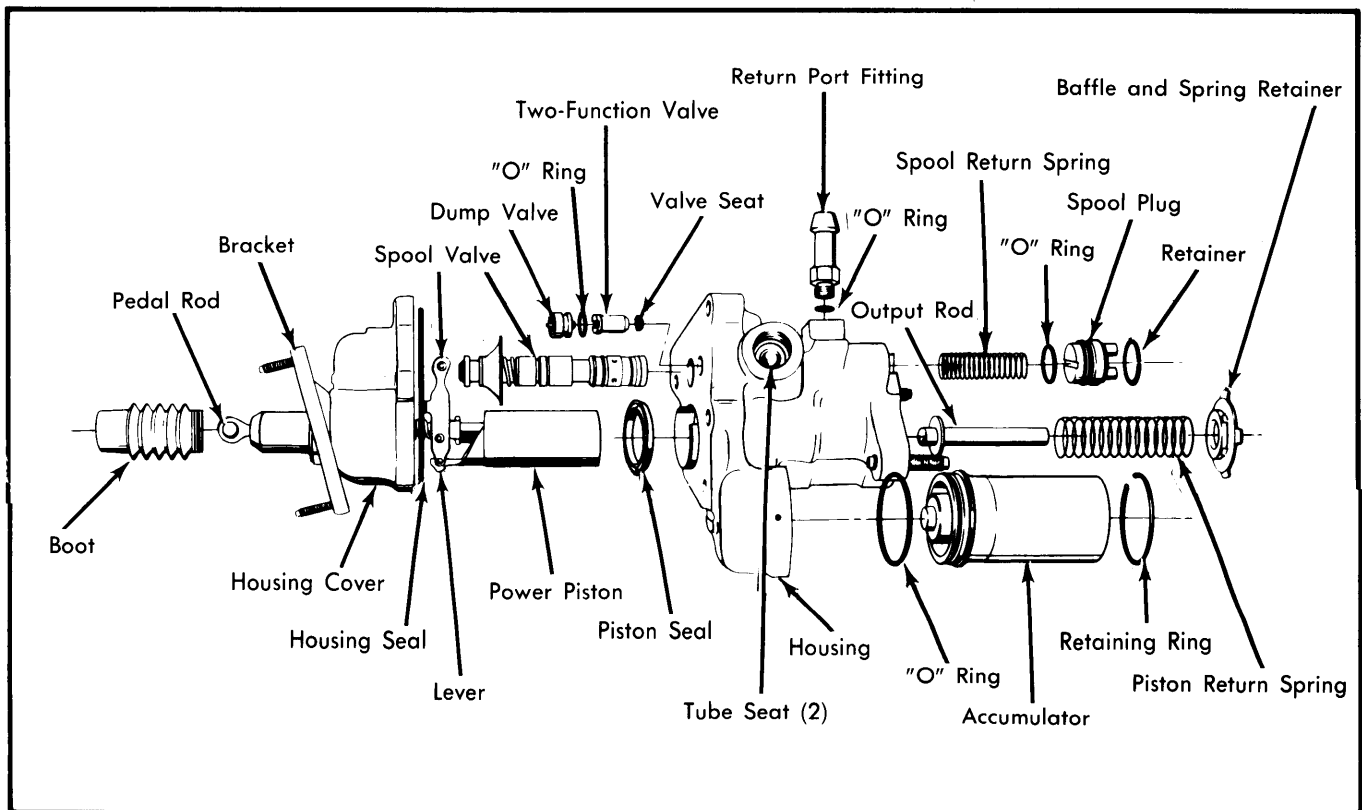

Fig. 3 Exploded View of Bendix Hydro-boost Assembly Components (Unit with External Accumulator Shown)

BENDIX HYDRO-BOOST (Cont.)

4) Place booster cover in a soft-jawed vise and remove 5 screws securing booster housing to cover. Remove booster assembly from vise and while holding over a pan, separate cover from housing. Remove large seal ring from groove in cover and discard.

5) Remove input rod and piston assembly, spool assembly and spool spring from booster housing. If spool valve is defective, the complete assembly must be replaced. Inspect power piston, if deep scratches are evident, input rod and piston must be replaced.

6) Remove input rod seals and piston seal from piston bore. Place retaining cap tool (see tool chart for number) over master cylinder stud and install nut as shown in Fig. 4. Using a large "C" clamp, depress accumulator. Insert a punch into hole in housing and remove retaining ring with screwdriver.

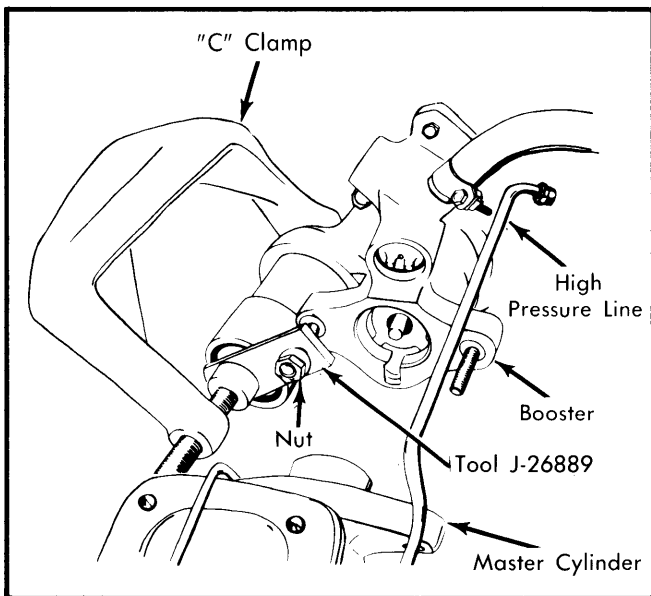

Fig. 4 Compressing Accumulator

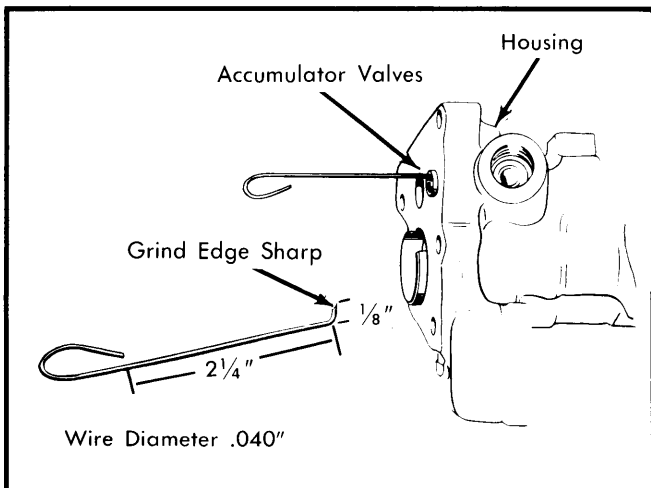

Fig. 5 Removing Accumulator Valves

7) Slowly back off clamp until tension on accumulator is released, then remove accumulator and "O" ring. If accumulator valve is faulty, remove valve using a small diameter wire tool. See Fig. 5. Remove the dump valve by catching the tool under the pin guide near the center of the valve, then remove the 2-function valve and seat.

8) Remove return hose "O" ring fitting if it is leaking. Remove spool valve plug, retaining ring and "O" ring. Remove tube seats using a No. 4 Easy Out.

Cleaning & Inspection – 1) Clean all metal parts in a suitable solvent. Inspect valve spool and valve spool bore in booster housing for corrosion, nicks, scoring or other damage. Discoloration of spool or bore, particularly in grooves, is not harmful.

2) If valve spool or spool bore has nicks or scoring that can be felt with a fingernail, particularly on the lands, the entire booster should be replaced as an assembly.

3) Inspect input rod, piston assembly, and piston bore for corrosion, nicks, scoring or other damage. Replace damaged parts.

Reassembly – 1) Be sure that all parts are absolutely clean. Lubricate all seals and metal friction points with power steering fluid.

2) On Chevrolet and GMC models, install tube seat as shown in Fig. 6. On Dodge and Plymouth models, position tube seats in booster ports and screw a spare tube nut into each port to seat tube seat. Remove spare nuts and ensure that ports are free from burrs or shavings.

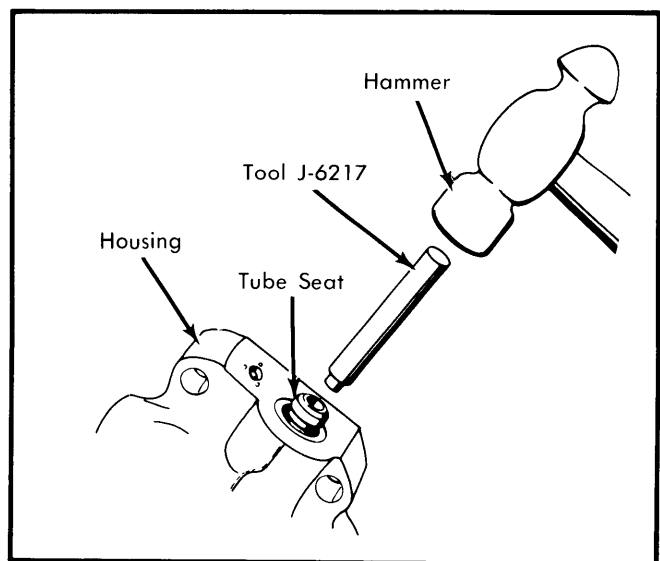

Fig. 6 Installing General Motors Tube Seats

3) On all models, install "O" ring, spool valve plug and retaining ring. Coat piston seal and bore with clean power steering fluid and place seal in bore. Lip of seal must face away from master cylinder mounting flanges. Lubricate input rod end, new input rod seals, and seal installer tool (see tool chart for number) with clean power steering fluid.

BENDIX HYDRO-BOOST (Cont.)

4) Slide seals on tool with lip of cups toward open end of tool. See Fig. 7. Slide tool over input rod end and down to second groove. Then slide forward seal off tool and into groove. Assemble other seal in first groove. Make sure both seals are seated.

NOTE — Chevrolet and GMC diesel models use only 1 seal on input rod.

5) Lubricate piston and piston installation tool (see tool chart for tool number) with clean power steering fluid. Hold the large end of the tool against the piston and slide the tool and piston into the piston bore and through the piston seal. Remove tool. Install return hose "O" ring fitting. If accumulator valve was removed, install new seat in valve bore by installing 2-function valve, which forces seat to bottom in bore.

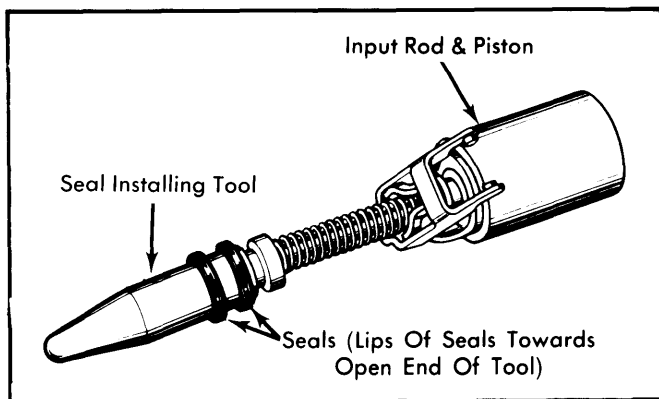

Fig. 7 Installing Input Rod Seals

6) If removed, insert new dump valve over the 2-function valve, making certain the dump valve plunger is held in place until installation is complete. Insert spool valve spring and valve assembly into bore. Extend power piston lever to accept sleeve on spool valve, then slide lever pins into slot in sleeve.

7) Install new seal in groove in housing cover, then join booster housing and cover and secure with 5 screws. Install output rod, spring and new spring retainer. Install new baffle and spring retainer by pushing in on it with a 7/8" socket.

8) Lubricate accumulator seal with clean power steering fluid and install seal and accumulator in housing. Place retaining ring over accumulator. Place retaining cap tool (see tool chart for number) over accumulator. Using a "C" clamp, compress

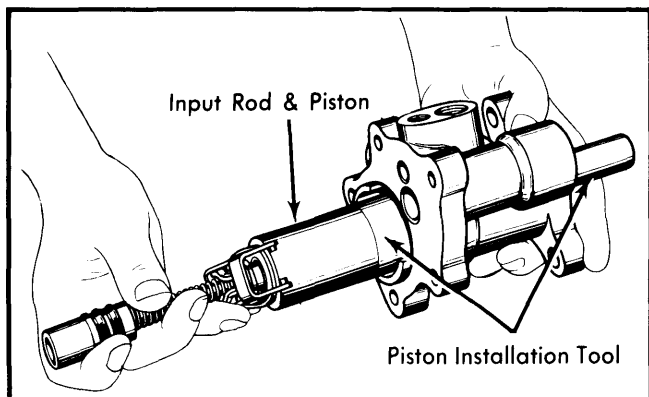

Fig. 8 Installing Input Rod Assembly into Booster

accumulator straight in. Snap retaining ring into the housing groove, and remove "C" clamp and tool.

9) Position mounting on booster. Tab on inside diameter of large hole in bracket should fit into slot in threaded portion of booster hub. Install new bracket nut with staking groove outward on the threaded hub of booster. Using deep socket tool (see tool chart for tool number) and a torque wrench, tighten nut to 110 ft. lbs.

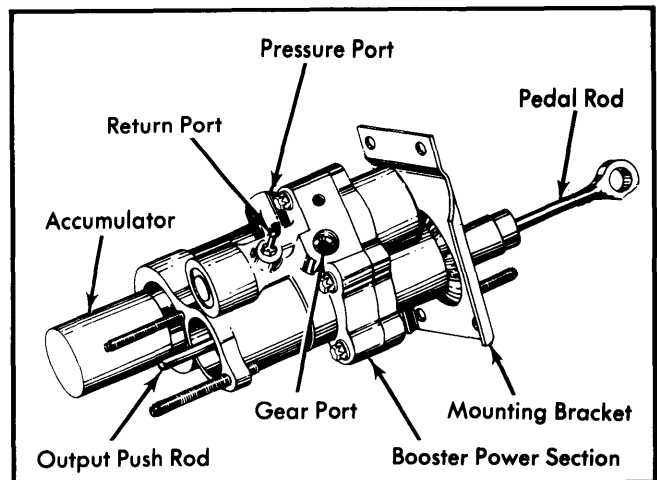

Fig. 9 Bendix Hydro-Boost Assembly

10) Using a hammer and punch, stake the nut in place. Assemble boot (if used) on pedal rod. Assemble new grommet in groove near end of pedal rod. Moisten grommet with water and insert grommet end of the pedal rod into the input rod end of the booster housing. Push on end of pedal rod to seat grommet. Slide the boot on the pedal rod and assemble the large end of the boot onto the hub of the power section.

TOOL NUMBER CHART

Application	GM Number	Chry. Number
Retainer Shearer	J-24569	C-4396
Retaining Cap Tool	J-26889
Input Rod Seal Tool	C-4394
Rear Drum Models		
Gasoline	J-24553
Diesel	J-28485
Rear Disc Models	J-28497
Piston Installation Tool	C-4393
Diesel Models	J-25083
All Others	J-24551
Special Deep Socket ...	J-24554	C-4395
Tube Seat Installer	J-6217

TIGHTENING SPECIFICATIONS

Application	Ft. Lbs.
Booster Housing	20
Mounting Bracket Nut	110
Booster Brackets	25