

Master Cylinders

BENDIX MINI-MASTER CYLINDER

Chevrolet
GMC

DESCRIPTION

Functions of the Bendix Mini-Master cylinder are basically the same as a conventional master cylinder although components differ. When master cylinder is in released position, primary and secondary actuators are in contact with compensating valve stems which project into cylinder bore. This keeps valves off their seat and opens communication between cylinder bore and reservoir. The initial forward movement of piston permits compensating valves to seat, this closes communication between pressure chambers in cylinder bore and reservoir. As piston travels further, pressure build up is transmitted to calipers and wheel cylinders.

ADJUSTMENT

BRAKE PEDAL

See *Bendix Hydroboost* article in this Section.

REMOVAL & INSTALLATION

Removal – Depress and release brake pedal several times with engine not running. This will make sure that all pressure is discharged from accumulator. Clean dirt and grease from

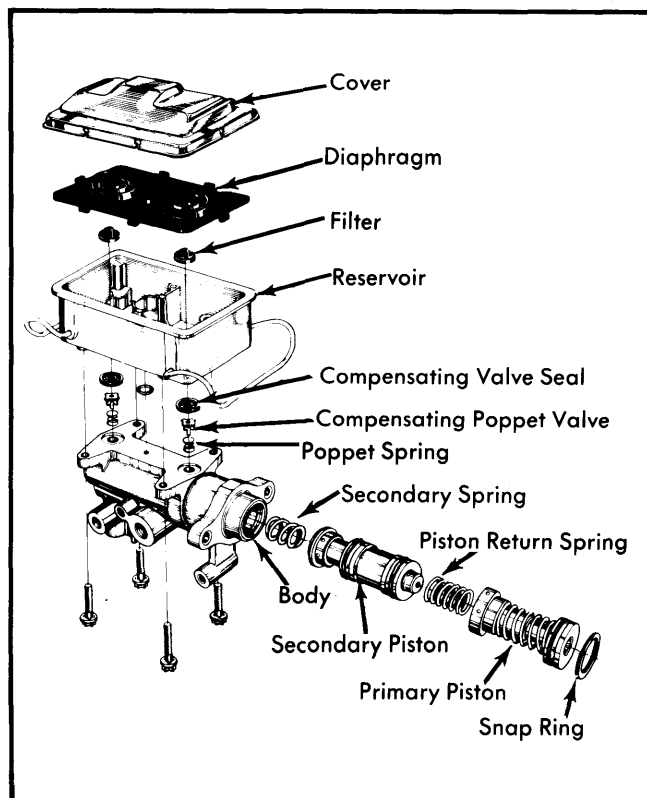

Fig. 1 Exploded View of Bendix Mini-Master Cylinder

hydraulic brake line connections. Disconnect brake lines from master cylinder. Remove nuts and washers that secure master cylinder to Hydroboost. Remove master cylinder. Cover open ends of brake lines.

Installation – To install, reverse removal procedure. **Bleed** brake hydraulic system. See *Hydraulic Brake Bleeding in this Section*.

OVERHAUL

MASTER CYLINDER

Disassembly – 1) Remove reservoir cover and diaphragm. Drain all brake fluid. Remove four reservoir bolts and separate reservoir and master cylinder body. Remove small "O" ring and both compensating valve seals from bottom of reservoir. **DO NOT** remove 2 filters from bottom of reservoir unless they are damaged. Push in primary piston and remove compensating valve poppets and springs from ports in master cylinder body.

2) Remove snap ring from master cylinder bore using a small screwdriver. Release primary and secondary pistons and remove from bore. It may be necessary to plug front outlet port and apply low air pressure to front compensating valve port to remove secondary piston assembly.

CAUTION – If air pressure is used to remove piston, place open end of bore 1" away from padded surface to catch piston and prevent personal injury.

Cleaning & Inspection – Clean all reusable components in clean brake fluid. Make sure filters in bottom of reservoir are clean. If filters do not clean thoroughly, they must be replaced. After cleaning, inspect all components for wear or damage and replace as necessary.

Reassembly – 1) Lubricate primary and secondary pistons, and cylinder bore with clean brake fluid. Position secondary spring (short spring) in open end of secondary piston actuator. Position return spring (long spring) on projection at rear of secondary piston. Place secondary piston, actuator end first in master cylinder bore and press assembly into bottom of bore. Insert primary piston, actuator end first into bore.

2) Using a smooth round end tool with snap ring placed over it, depress piston in bore. Install snap ring in groove. Place compensating valve seals and small "O" ring seal in recesses in bottom of reservoir. Make sure seals are fully seated. Depress pistons and place compensating valve springs and poppets in valve ports. With piston still depressed, place reservoir in position. Install bolts and tighten to 12 to 15 ft. lbs.