

## GENERAL MOTORS

### All Models

**Steering System Service Precautions** — All steering component fasteners are made of special quality materials. Replacement fasteners must be of same part number or equivalent. Torque all fasteners to specification and install new cotter pins. When installing cotter pins, do not back off castellated nuts to align cotter pin hole, tighten nut to next slot that lines up with hole. Do not hammer on ball studs or damage to threads may result. If threads are not clean and smooth, ball studs may turn in joint when nuts are tightened. Sleeve clamps must always be positioned as specified before tightening bolts.

**Tie Rod Removal** — 1) Raise vehicle and remove tie rod fasteners. Remove outer ball stud by tapping on steering arm at tie rod end with a light hammer while using a heavy hammer as a backing. Remove inner ball stud from relay rod using same procedure.

2) To remove tie rod ends from tie rod, loosen clamp bolts and unscrew end assemblies. Tie rod adjuster clamp bolts often become rusted in service. It is recommended that if torque required to remove the nut from a bolt after breakaway exceeds 7 ft. lbs., discard the nuts and bolts. Apply penetrating oil between clamps and tube, and rotate clamps until they move freely. Use new fasteners of same part number during reassembly to assure proper clamping at specified nut torque.

3) To install tie rods, use following procedure: Lubricate tie rod threads with EP chassis lube and install tie rod ends making sure both are threaded an equal distance from tie rod. Check that threads on ball studs and nuts are clean and smooth. Check condition of ball stud seals and replace if necessary using suitable tool (J-24434). Install ball studs in steering arms and relay rod. Install ball stud nuts and torque to specifications, and install new cotter pins. Adjust toe-in. See *Wheel Alignment Specifications & Procedures* in WHEEL ALIGNMENT Section.

4) Before tightening tie rod adjusting sleeve clamp bolt, note the following: Clamps must be between locating dimples at either end of sleeve. Adjuster sleeve slot must not be within open area of clamp jaw opening (see Fig. 6 and 7).

5) Rotate both inner and outer tie rod housing rearward to limit of ball joint travel before tightening clamps. After tightening clamps, return tie rod assembly to center of travel. Check each tie rod for a rotation of at least 35° using a bubble protractor and a pair of vise grips. Lubricate inner and outer tie rod ends.

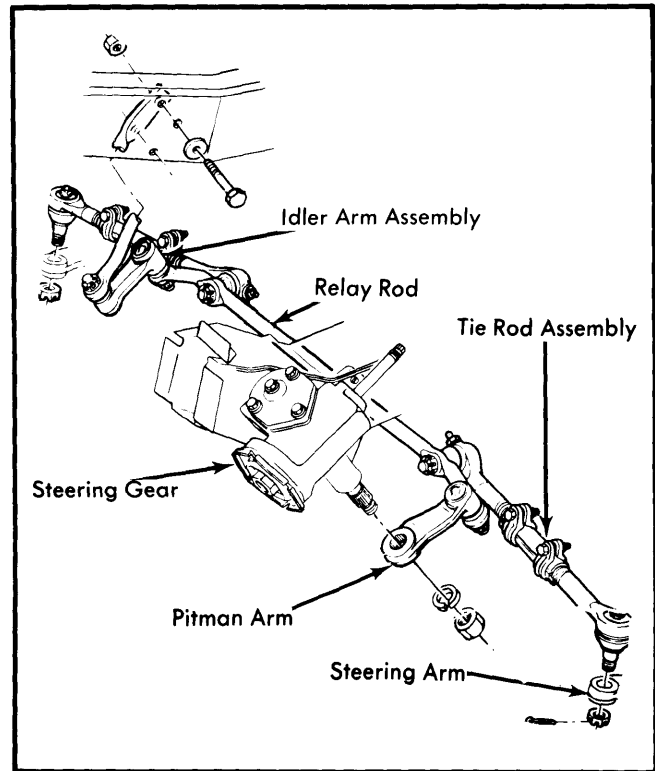

Fig. 2 "G" Model Steering Linkage

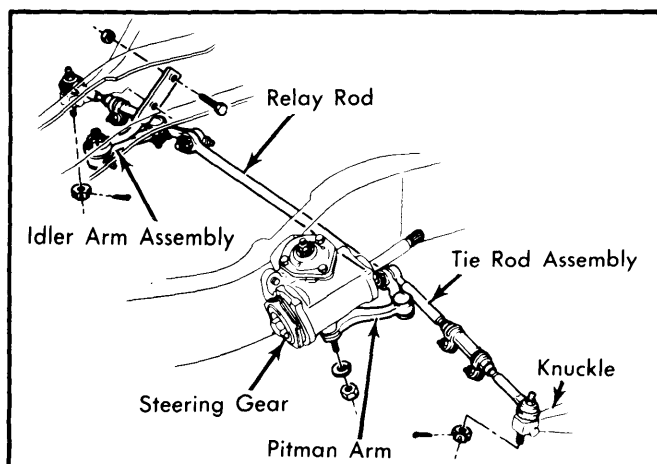

Fig. 1 "C" Model Steering Linkage

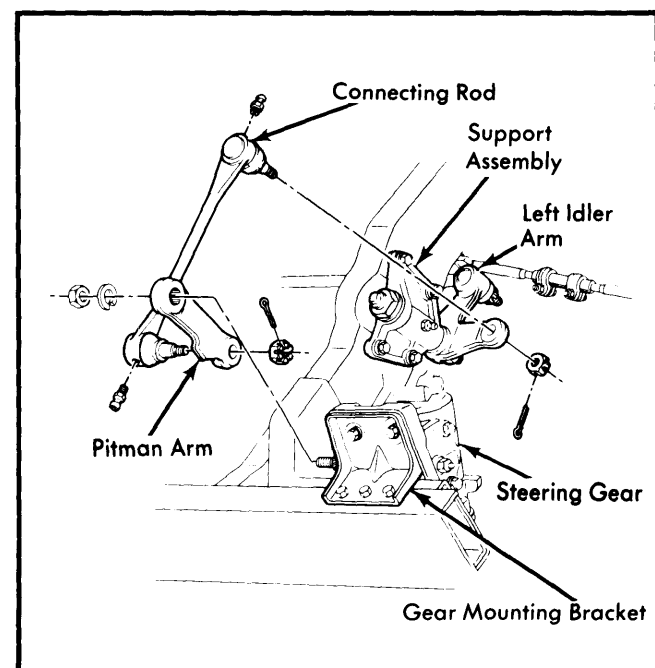

Fig. 3 "P" Model Steering Linkage

# Steering Linkage

## GENERAL MOTORS (Cont.)

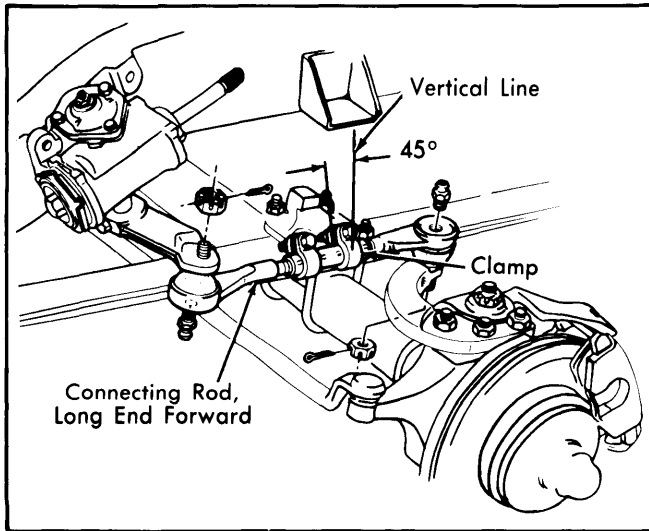

Fig. 4 "K" Model Steering Linkage

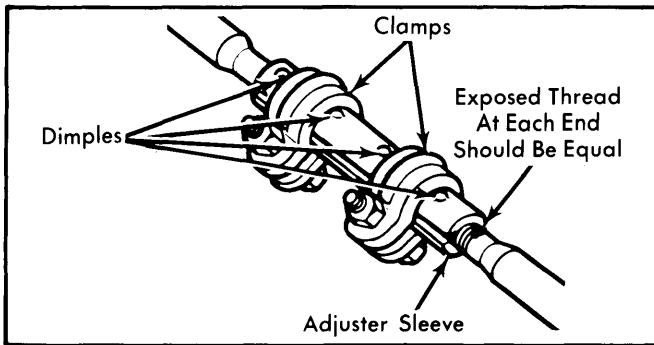

Fig. 5 Position of Tie Rod Clamps

**Relay Rod Removal** - 1) Raise vehicle on hoist. Remove inner ends of tie rods from relay rod. Remove nuts from pitman arm and idler arm ball studs at relay rod. Remove relay rod from pitman and idler arms by tapping on relay rod ball stud bosses with a light hammer while using a heavy hammer as backing. Remove relay rod.

2) To install, reverse removal procedure and note following: Check ball studs and nuts for clean and smooth threads. Check stud seals and replace if necessary. Torque nuts and install new cotter pins.

**Idler Arm Removal** - 1) Place vehicle on a hoist. Remove fasteners from ball stud at relay rod. Remove ball stud from relay rod by tapping on relay rod boss with a hammer, while using another hammer as a backing. Remove idler arm-to-frame bolts and remove idler arm assembly. **NOTE** - Idler arm assembly should always be replaced if it is found that an up and down force of 25 lbs., applied at relay rod end of idler arm, produces a vertical lash of more than 1/8" in straight ahead position.

2) To install, reverse removal procedure while noting the following: Ensure that threads on studs and nuts are clean and smooth. Check ball stud seals and replace if necessary. Install connecting rod while making sure long end of rod is toward

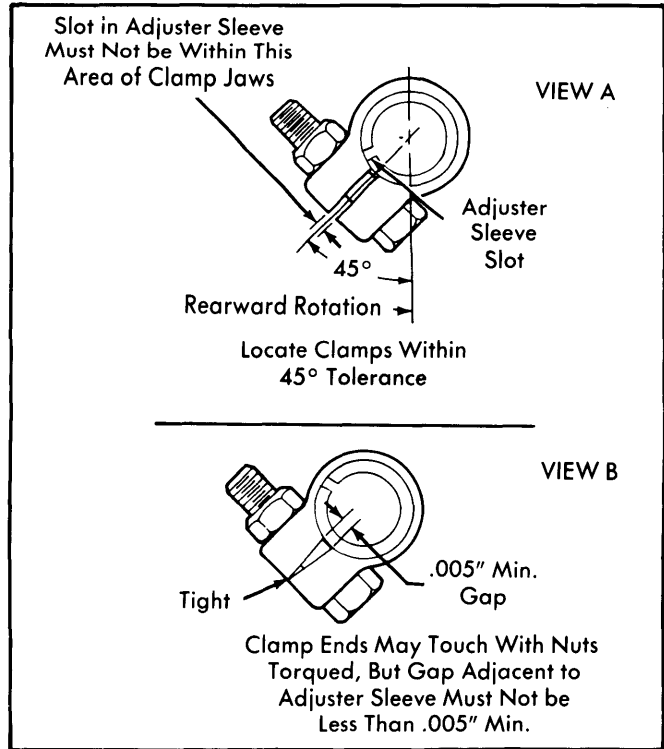

Fig. 6 Tie Rod Clamp Position "C", "K" and "P" Models

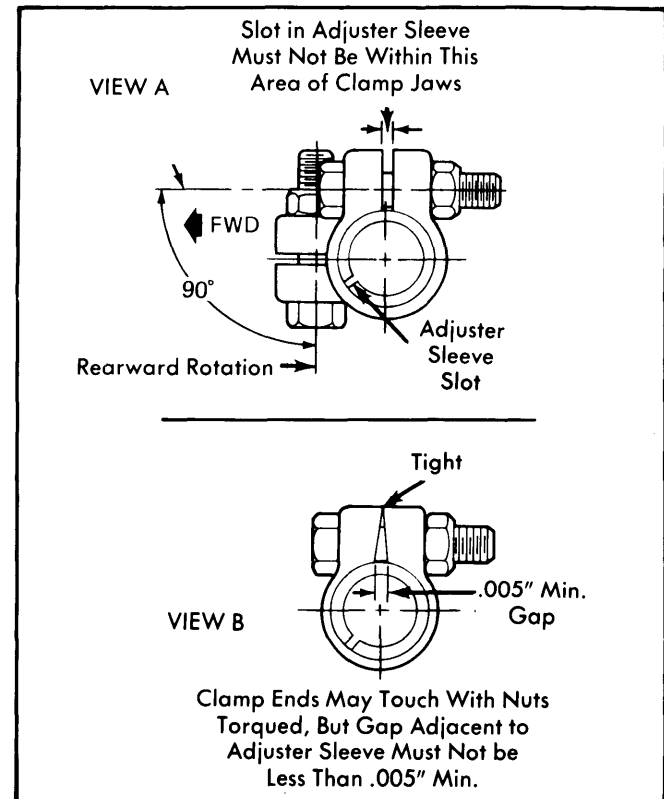

Fig. 7 Tie Rod Clamp Position "G" Model

## GENERAL MOTORS (Cont.)

pitman arm. See illustrations for proper alignment and orientation of connecting rod clamps.

**Pitman Arm Removal** – 1) Raise vehicle on a hoist. Remove cotter pin from pitman arm ball stud and remove nut. Remove pitman arm or relay rod from ball stud by tapping on side of rod or arm (in which stud mounts) with a hammer while using another hammer as a back-up. Remove pitman arm nut from shaft or clamp bolt from pitman arm, and mark arm-to-shaft position. Remove pitman arm from shaft using suitable puller.

2) To install, reverse removal procedure and note following: If a clamp type pitman arm is used, spread pitman arm with a wedge just enough to slip arm onto shaft by hand pressure. Do

not hammer or damage to steering gear may result. Be sure to reinstall the hardened steel washer before installing nut.

### "K" Models

**Steering Connecting Rod** – 1) Remove cotter pins from ball studs and remove castellated nuts. Remove ball studs from steering arm and pitman arm boss with a heavy hammer and striking other side of boss with a lighter hammer.

2) To install, reverse removal procedure and note following: Ensure that threads on studs and nuts are clean and smooth. Check ball stud seals and replace if necessary. Install connecting rod on steering components, torque nuts and install new cotter pins. See illustration for proper alignment and orientation of connecting rod clamps.

## TIGHTENING SPECIFICATIONS

| Application                           | Ft. Lbs. | Application  | Ft. Lbs. |
|---------------------------------------|----------|--|----------|
| Tie Rod Ball Stud Nuts .....          | ①45      | Pitman Arm-to-Pitman Shaft Nut   |          |
| Tie Rod Clamps .....                  | 22       | K10-20 .....   | 90       |
| Idler Arm Mounting Bolt .....         | 30       | "P" Motor Home Chassis .....   | 125      |
| Idler Arm-to-Relay Rod Nut            |          | All Other Models .....   | 185      |
| G10-30 .....                          | 70       | Pitman Arm-to-Idler Support Arm Nut  |          |
| All Other Models .....                | 60       | P10-30 & "P" Motor Home Chassis .....  | 125      |
| Pitman Arm-to-Relay Rod Nut           |          | Relay Support Assembly-to-Frame Nut  |          |
| G10-30 .....                          | 70       | P10-30 & "P" Motor Home Chassis .....  | 48       |
| All Other Models .....                | 60       |  |          |
| Steering Connecting Rod Nut           |          | ① – Plus torque required to align cotter pin with maximum torque of 60 ft. lbs.  |          |
| P10-30 & "P" Motor Home Chassis ..... | ②70      | ② – Plus torque required to align cotter pin with maximum torque of 100 ft. lbs. |          |
| K10-20 .....                          | ③50      | ③ – Plus next slot for cotter pin.   |          |
| Steering Connecting Rod Clamps        |          |  |          |
| K10-20 .....                          | 40       |  |          |

## INTERNATIONAL HARVESTER

### All Models

**Tie Rod Removal** – Remove cotter pins from ball studs at each end of tie rod. Remove nuts. Separate tie rod end ball studs from steering arms. To install, reverse removal procedure. Install new cotter pins.

**Tie Rod End Replacement** – Loosen tie rod end clamp bolts. Unscrew tie rod end from tie rod. To install, reverse removal procedure. Make sure tie rod end is threaded into tie rod sufficiently so that clamping action will be directly over threads. Position clamp on tie rod as shown in illustration (see Fig. 2).

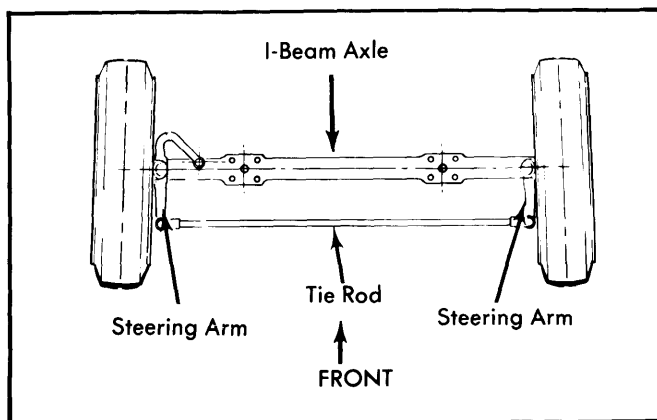

Fig. 1 Steering Linkage for International Scout

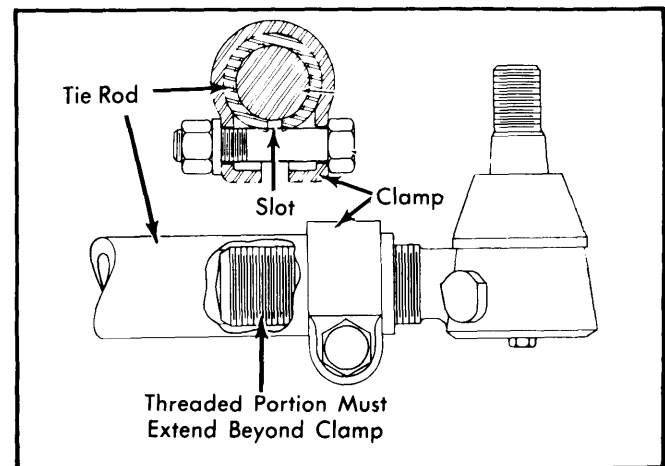

Fig. 2 Positioning Clamps on Tie Rod