



## CHRYSLER CORP. (Cont.)

**Installation** — 1) Install ground clip on left capsule slot. Plastic capsules should be preassembled in bracket slot. Insert column through floor pan opening. With front wheels straight ahead and splines on wormshaft and coupling aligned, engage coupling and install roll pin.

**CAUTION** — Do not apply end load to steering shaft.

2) Hold column assembly with bracket slots on mounting studs. Loosely install two upper bracket washers and nuts. Be sure both capsules are fully seated in slots in support bracket and tighten nuts to specification.

3) Position floor plate over floor pan opening, centering it around column, then install retaining bolts. Place steering wheel on shaft with splines aligned. Install nut and tighten to specifications.

**CAUTION** — Do not drive wheel onto shaft, draw it down with retaining nut.

4) Install horn switch and connect wiring connector at column jacket. Connect shift links into new grommets.

**NOTE** — Whenever column is removed or loosened, linkage adjustment must be checked. See Shift Linkage Adjustment in TRANSMISSION Section.

5) If equipped with automatic transmission, connect gear shift indicator pointer cable to indicator bracket. Slowly move shift

lever from "1" (Low) to "P" (Park) pausing briefly at each position. If necessary, bend indicator bracket to align pointer with each position. Reinstall panel lower reinforcement and cluster bezel. Connect battery and test horn and lights.

### FLOOR SHIFT MODELS

The steering column with a floor mounted gear shift is basically the same as previously described. Standard columns and service procedures are identical except as described below.

- Lower steering shaft bearing is mounted in an aluminum support.
- Shift housing has a spring attached between it and column jacket. This keeps housing rotated counterclockwise against rubber bumper. Spring and bumpers are easily removed by hand.

### OVERHAUL

#### ALL MODELS (EXCEPT TILT WHEEL MODELS)

**Disassembly** — 1) Pry out wiring trough retainers and lift off trough. New retainers may be required for reassembly. Use masking tape to protect paint and a deep socket to back up housing and drive retaining roll pin out with a punch to remove shift lever. Secure column in vise by clamping at column bracket. Do not distort column.

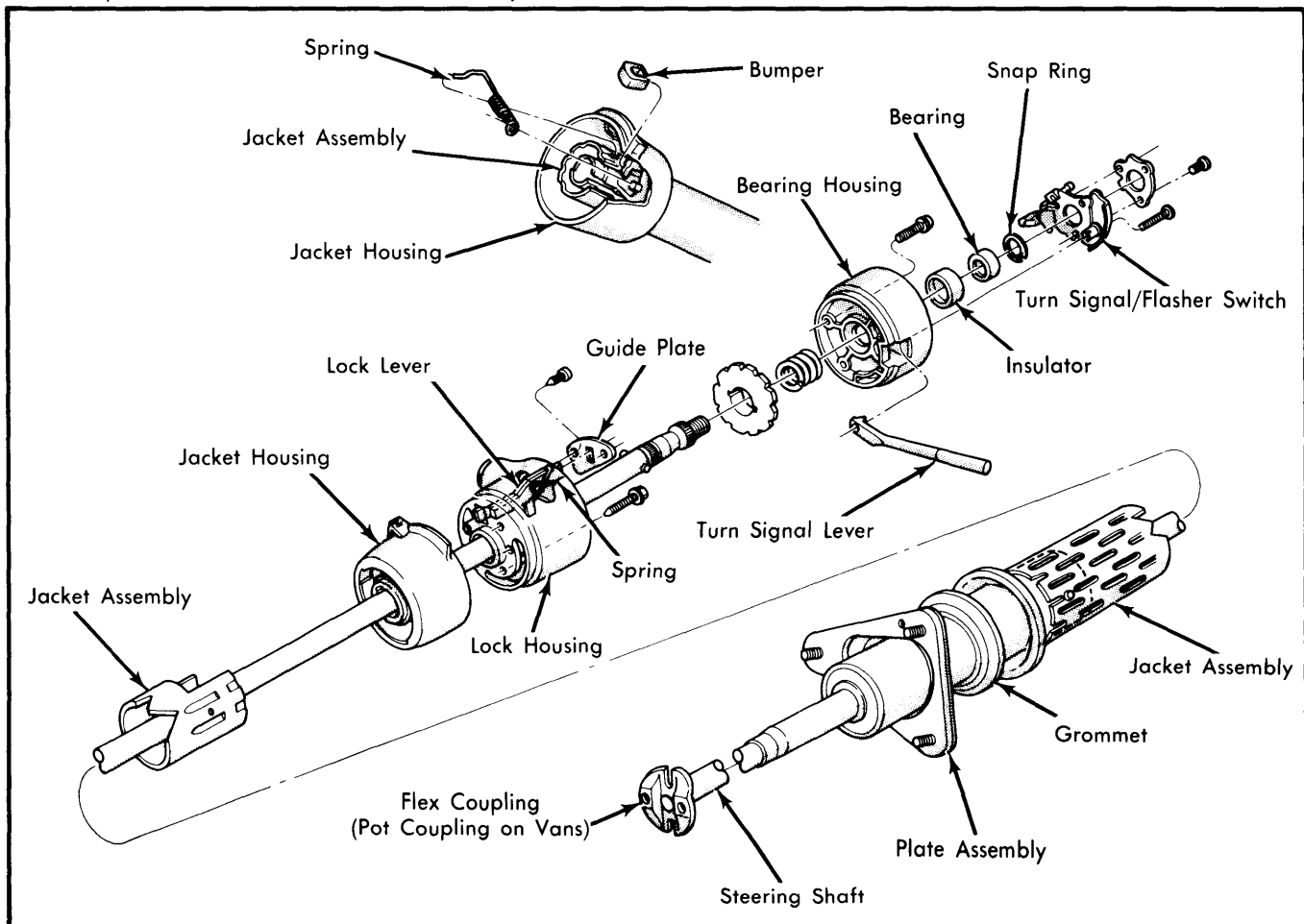

**Fig. 2 Exploded View of Floor Shift Steering Column (Pickup Models Shown; Van Models Similar)**

## CHRYSLER CORP. (Cont.)

2) Remove turn signal switch and upper bearing retaining screws. Remove retainer and lift switch upward out of way. Remove retaining screw and lift ignition key lamp assembly out of way.

3) Remove snap ring from upper end of steering shaft. Remove three screws holding bearing housing-to-lock housing.

**NOTE** — These screws must be removed before steering shaft removal.

4) Remove bearing housing from shaft. Remove coil spring and lock plate from shaft. Remove shaft through lower end of column.

5) Remove two retaining screws and lock lever guide plate. This will expose lock cylinder release hole. Place cylinder in "LOCK" position and remove key.

6) Insert a small diameter screwdriver or similar tool into lock cylinder release hole. Push in to release spring-loaded lock retainer. At same time, pull lock cylinder out of housing bore. Remove three retaining screws and ignition switch assembly.

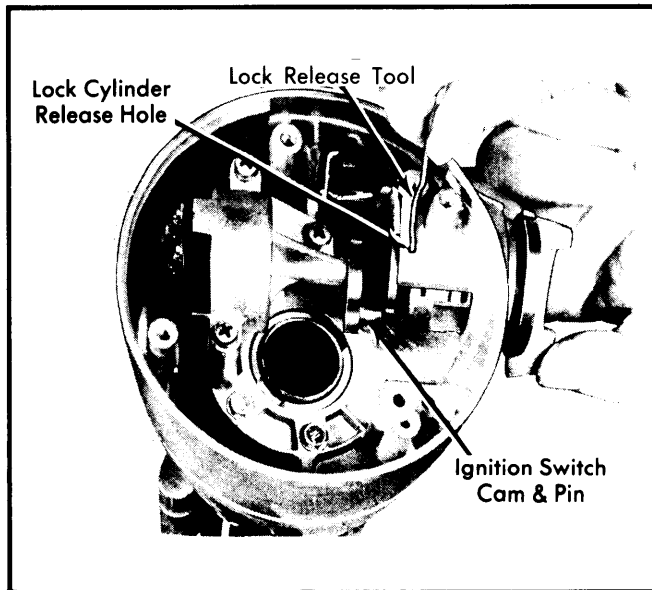

Fig. 3 Removing Lock Cylinder

7) Grasp lock lever and spring assembly and pull straight out of housing. Remove four lock housing-to-column jacket hex head retaining screws and remove housing from jacket.

8) Loosen shift tube set screw in shaft housing. Remove shift tube through lower end of jacket. Remove floor plate and grommet from jacket.

9) To disassemble flexible coupling, remove four bolts and two cross straps. Remove flexible coupling. Pot coupling is removed by prying cover tangs out of coupling body and lift seal and cover from body. Drive dowel pin down into coupling and discard. Pull body off shaft and shoe assembly.

**Reassembly** — 1) During reassembly, coat all friction surfaces with multi-purpose grease NLGI Grade 2, Part Number 2525035 (or equivalent). Clamp column in vise so that both ends of column are accessible. Check column tube-to-mandrel rivets for tightness. If replacement is necessary, use  $\frac{3}{8}$ " diameter by  $\frac{3}{4}$ " long ( $\frac{3}{8}$ " grip) steel pop rivets.

**NOTE** — Never use aluminum rivets.

2) Install floor plate and grommet on lower end of jacket. On automatic transmission models, position gearshift housing on column jacket. Install dust seal and shift tube support on shift tube. Slide shift tube into jacket. Guide key on upper end of tube into slot in gearshift housing. Position crossover load spring and shift lever in gearshift housing and tap rivet pin into place. Install shift lever gate on lock housing.

3) If equipped, feed gear selector dial lamp wire through hole behind transmission dial on lock housing and route wire through space between housing and jacket. Secure lamp assembly and install gear selector lens assembly. Place shift lever in mid position, seat lock housing on top of jacket and indexing key in housing with slot in jacket. Install housing-to-jacket screws and tighten alternately. Install automatic transmission indicator bracket.

4) Grease and assemble the two lock levers, lock lever spring and pin. Install the assembly into the lock housing. Seat the pin firmly in the bottom of the slots. Make sure the lock lever spring leg is firmly in place in lock casting notch.

5) Install the lock lever guide plate and retaining screws. Position ignition switch to "OFF" position and hand lever in "PARK". Feed wires down through the space between housing and jacket. Position switch in housing and tighten mounting screws.

6) To install ignition lock, turn key to "LOCK" position and remove key. The cylinder will move inward and a spring loaded retainer will snap into place, locking the cylinder into the housing.

7) Fill coupling body  $\frac{1}{4}$ " full with multi-purpose grease and place cover and seal on shaft. Press shoe pin into steering shaft so it protrudes an equal distance on each side of the shaft. Place spring on side of shaft so it straddles the shoe pin. Place shoes on pin ends with flat side toward spring, engaging tangs.

8) Squeeze shoes together, compressing spring, and push assembly into coupling body. Align master spline mark of coupling body with master spline on upper shaft. Drive in a new dowel pin flush to coupling body outer surface. Position seal and cover on body and crimp cover tangs on body. Move shaft in and out several times to distribute lubricant.

9) Install bearing support (floor shift), bearing and spring on steering shaft and insert steering shaft into column assembly. Install lock plate and new groove pin on steering shaft. Make sure pin is centered. Install steering column shaft lock plate sleeve over shaft lock plate pin and against lock plate. Install bearing lower snap ring on steering shaft. Install coil spring.

10) Install ignition key lamp assembly in housing. Place rubber insulator with grounding staple over column upper bearing and install assembly into bearing housing bore. Use soap solu-

## CHRYSLER CORP. (Cont.)

tion or rubber lubricant to ease installation. Install turn signal switch in bearing housing, feeding wires through opening in housing. Feed ignition key lamp wires through opening in housing. Install retaining plate over switch and tighten screws.

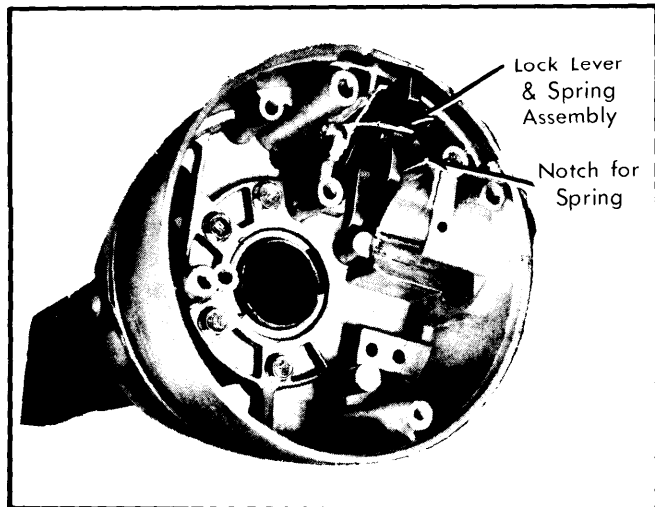

**Fig. 4 Lock Lever and Spring Assembly Installed in Housing**

11) Install turn signal lever or turn signal/speed control lever on turn signal switch. If speed control, feed wires through opening provided in bearing housing. Position housing assembly on steering shaft, feeding wires through space between housing and jacket. Install bearing and snap ring on shaft.

12) Install bearing housing-to-lock housing screws and tighten. Install wiring trough in place over wires, being careful not to pinch wires between trough and jacket. Install new retainers if required.

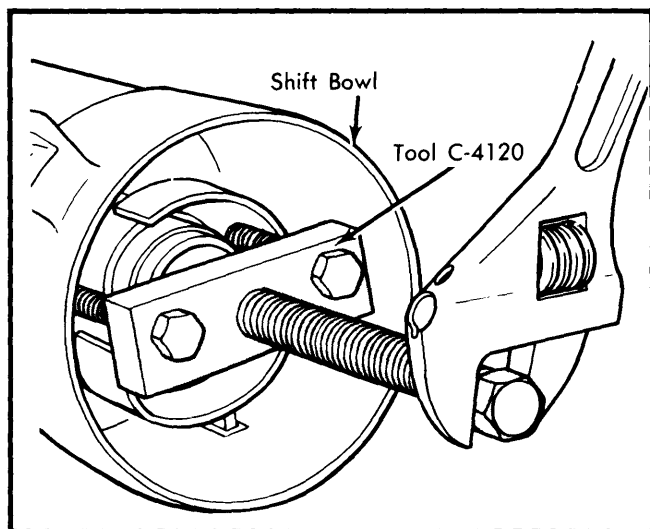

**Fig. 5 Removing Shift Tube from Bowl on Tilt Column Models**

### TILT WHEEL MODELS

**Disassembly** - 1) Remove steering wheel and column. Remove bracket assembly-to-column jacket bolts. Remove wiring protector from jacket. Attach holding fixture (C-4132) to jacket and mount column in vise. Remove tilt lever and turn signal or speed control lever. Push hazard warning knob in and unscrew to remove. Remove ignition key lamp assembly.

2) Move tilt mechanism to full down tilt. Carefully remove plastic cover from lock plate. Depress lock plate with finger and pry ring out of groove with screwdriver. Remove lock plate, cancelling cam and upper bearing spring.

3) Remove three turn signal switch screws, place shift bowl in low (1) position. Tie up wires and connectors to prevent snagging, remove switch and wiring. To remove lock cylinder, place in "LOCK" position. Insert a thin tool into slot next to switch mounting screw boss (right hand slot) and depress spring latch at bottom of slot to remove lock.

4) Remove housing cover screws and remove housing cover. Reinstall tilt lever and place column in full "UP" position. Remove tilt spring retainer with a phillips screwdriver. Insert screwdriver in opening and press in  $\frac{3}{16}$ ". Turn about  $\frac{1}{8}$  turn counterclockwise until ears align with groove in housing and remove spring and guide.

5) Push upper steering shaft in sufficiently to remove steering shaft inner race seat and inner race. Put ignition switch in "ACC" position and remove ignition switch.

6) Place pivot pin remover (C-4016) over pivot pin, thread small portion of screw into pin. Hold screw in position, turn nut clockwise and remove pivot pin from support. Remove opposite pivot pin. Use tilt release lever to disengage lock shoes. Remove bearing housing by pulling upward to extend rack fully. Move housing to left to disengage rack from actuator, remove actuator assembly.

7) Remove roll pin and coupling assembly from lower end of steering shaft. Remove shaft from upper end of column. Disassemble steering shaft by removing center spheres and anti-lash springs. Remove bolts securing support to lock plate and remove support from end of column jacket. If needed remove attaching screws and shift gate from support.

8) Using screwdriver remove shift tube retaining ring and thrust washer. With a small screwdriver disengage plastic shift tube support from lower end of jacket. Remove shift tube from bowl using tool (C-4120). Insert bushing on end of tool in shift tube and force tube out of bowl.

**CAUTION** - Do not hammer or pull on shift tube as plastic joint may be sheared.

9) Remove shift tube from jacket at lower end. Remove lock plate by sliding out of jacket notches and tapping down toward hub at 12 o'clock position and under jacket opening. Remove wave washer and bowl from jacket. Remove shift lever spring from bowl by winding spring up with pliers and pulling out.



## CHRYSLER CORP. (Cont.)

lash spring in upper steering shaft and lower steering shaft from same side of spheres that spring ends protrude.

4) Check double coupling assembly that master serration of upper shaft will align with master serration of pot coupling. Place housing in full "UP" position, install guide, tilt spring and tilt spring retainer using screwdriver. Turn retainer clockwise to engage. Install steering shaft in shift tube from upper end.

5) Place ignition switch actuator rod through bowl from bottom and insert slot in support. Extend rack downward from bearing housing, assemble housing over steering shaft and engage rack over end of actuator rod. Install external tilt release lever and holding lock shoes in disengaged position assemble bearing housing over steering shaft until pivot pin holes line up. Install pivot pins.

6) With housing in full "UP" position, install guide, insuring there is grease between guide and peg on support, tilt spring and spring retainer. Using a screwdriver in retainer slot turn retainer clockwise to engage. Install bearing inner race and tilt lever opening shield. Remove tilt release lever, install housing cover and tighten screws.

7) Install signal switch wires and connector. Push hazard warning plunger in, install switch and tighten screws. Install hazard warning knob and pull out.

8) Install cancelling cam spring, cancelling cam and shift lock plate. Using suitable tool (C-4156), depress shift lock plate and install new retaining ring. Install tilt release lever and turn signal switch lever.

9) To install ignition lock, turn key to "LOCK" position and remove key. Insert cylinder into housing enough to contact switch actuator. Press inward to move switch actuator rod up and down to align parts. When aligned, cylinder will move inward and spring loaded retainer will snap into place.

10) When replacing ignition switch, position key cylinder in "ACCESSORY" detent, then place switch in "ACCESSORY" as follows: Spring loaded position at one end is "START". Move slider to extreme other end, this is "ACCESSORY". Fit actuator rod into slider hole and assemble loosely to column.

11) Push switch lightly down column to remove lash in actuator rod and tighten mounting screws. Do not move switch out of detent. Install wire protector over wires on column jacket. Remove column from vise. Remove holding fixture. Position bracket assembly on steering column. Tighten bolts.

12) Align master splines and install coupling assembly on steering shaft. Drive in retaining roll pin. Install column on vehicle, replace steering wheel and road test vehicle.

### TIGHTENING SPECIFICATIONS

Application	Ft. Lbs.
Bearing Housing-to-Lock Housing Screws .....	2.9
Bracket-to-Column Bolt .....	10
Column Clamp Stud .....	1.6
Column Clamp Stud Nut .....	9
Flexible Coupling Bolts .....	16.6
Hazard Switch .....	2
Housing Cover Screws .....	8.3
Ignition Switch Screws .....	2.9
Lock Housing-to-Jacket .....	7.5
Shift Tube Support Screws .....	5
Steering Wheel Retaining Nut .....	60
Support Plate Bolts .....	5
Tilt Release Spring Retaining Screw .....	2.9
Turn Signal Retaining Plate .....	2.2
Upper Bracket Nuts .....	9.1