

Power Brake Units

Chevrolet
Dodge
Ford
GMC
IHC
Plymouth

BENDIX DUAL DIAPHRAGM

Installation — To install, reverse removal procedure noting the following: Before attaching master cylinder, check push rod for correct length.

OVERHAUL

NOTE — Only Chevrolet and GMC recommend overhaul of power brake unit.

Disassembly — 1) Scribe a mark across front and rear housings for reassembly. Remove master cylinder push rod. Remove both seals from rod.

2) Remove vacuum check valve and grommet. Remove dust boot and silencer from operating valve rod.

3) Using an awl, remove dust guard retainer, dust guard and silencers from rear plate. Reinstall steel retainer on hub.

4) Squirt denatured alcohol down valve operating rod. This will lubricate rubber grommet in valve plunger.

5) Position 2 small blocks of wood on either side of air valve rod and install end of air valve rod in a vise. Leave just enough room to position 2 open end wrenches between vise and retainer on hub of rear plate.

DESCRIPTION

Vacuum suspended power cylinder used with hydraulic brake system utilizes engine manifold vacuum and atmospheric pressure to provide power assisted brake application. Unit consists of three basic assemblies: vacuum power chamber comprised of front and rear shell, center plate, tandem front and rear diaphragms (with plate assembly), hydraulic push rod and vacuum diaphragm, and diaphragm return spring; mechanically actuated control valve integral with diaphragms; and a master cylinder.

REMOVAL & INSTALLATION

NOTE — Power brake unit can be removed without disconnecting hydraulic lines at master cylinder.

Removal — Disconnect vacuum line from check valve or power unit. Remove nuts securing master cylinder to power unit. Pull master cylinder forward away from unit. On Dodge "B" and "PB" models, remove linkage bellcrank pivot bolt. Remove power brake unit.

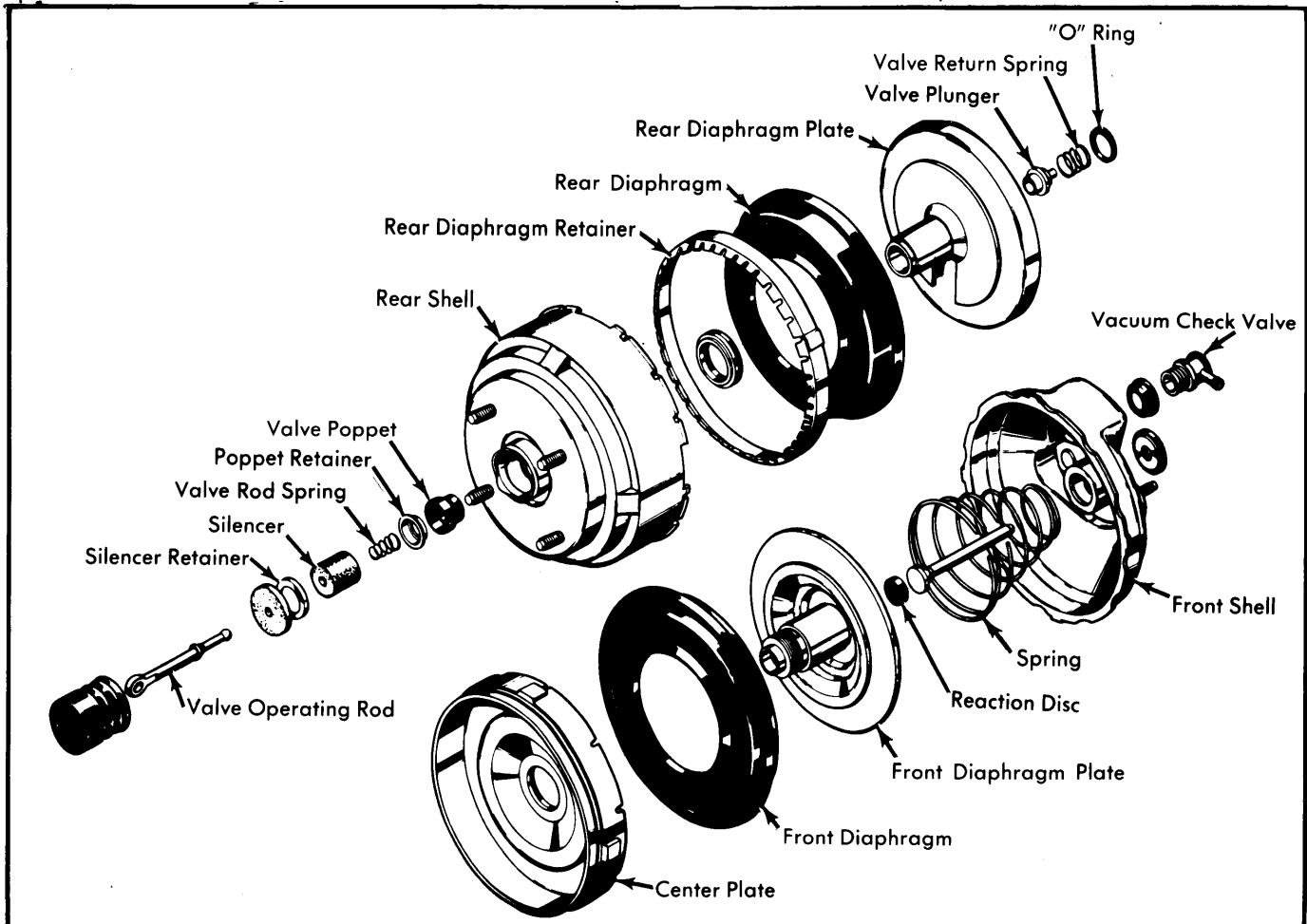

Fig. 1 Exploded View of Bendix Dual Diaphragm Unit

BENDIX DUAL DIAPHRAGM (Cont.)

6) Using wrench closest to vise as a pry, force air valve off ball end of rod. Care must be taken not to damage plastic hub or allow vacuum cylinder to fall out.

7) Of the 12 lances at the rear of the housing 4 are deeper than the rest. These must be straightened so that they will clear cutouts in front housing.

NOTE — If the metal breaks while being straightened, the housing must be replaced.

8) Remove push rod and vacuum seal from front housing. Attach a suitable holding fixture (J-22805) to front housing studs. Make sure nuts and washers are tight.

9) Place unit and holding fixture in arbor press with rear unit up. Place a 1½" wrench on holding fixture and allow wrench to contact rear of arbor press to prevent unit from turning. See Fig. 2.

10) Using a suitable spanner wrench (J-9504) over studs on rear unit. Bolt wrench to studs. Place a piece of pipe (2" I.D., 3" long) over plastic diaphragm plate hub.

11) Place a piece of flat stock over pipe. Using arbor press, press down on pipe enough to relieve tension of diaphragm rubber lip and spring.

12) Rotate spanner wrench counterclockwise until lances in edge of rear housing are aligned with cutouts in front housing. Considerable effort may be required.

CAUTION — The return spring is compressed in power section and expands as housings are separated. If the housings will not separate, tap housings with a rubber hammer to break seal.

13) After housings are separated, slowly release press until spring tension has been released. Remove front housing and return spring.

14) Remove spanner wrench and holding fixture. Work edges of front diaphragm from under lances of rear housing. Remove vacuum assembly from rear housing. Care must be taken not to damage rear housing seal.

15) Wet rear diaphragm retainer with denatured alcohol. Remove retainer with fingers. Place a suitable holding mandrel (J-22839) in a vise. Place the diaphragm and plate on tool with tool seated in front plate hex opening.

16) Turn rear diaphragm plate counterclockwise. After both plates have been loosened, remove plates from tool. Place on a bench with front plate down. Unscrew and remove rear plate from front plate. Retain air valve plunger and valve return spring as plates are separated.

17) Remove square ring seal from shoulder of front diaphragm plate hub. Remove reaction disc from inside front diaphragm plate hub.

18) Carefully remove center plate from hub of front plate. Remove diaphragms from plate. Use a punch or a 1¼" socket to drive seal from rear housings.

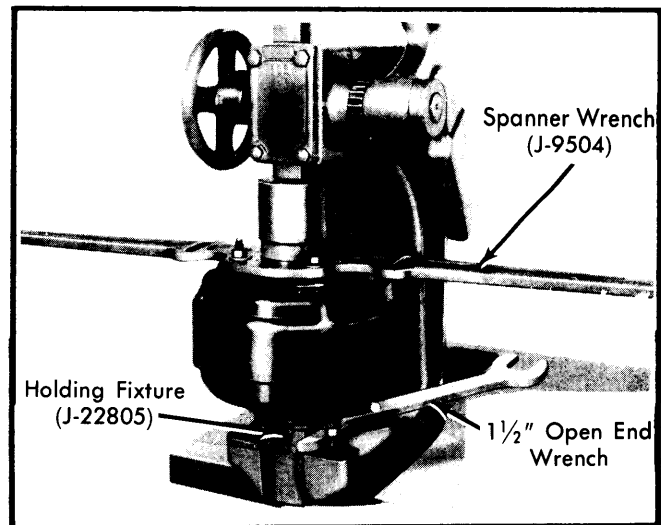

Fig. 2 Using Arbor Press and Suitable Tools to Separate Unit

Cleaning & Inspection — Clean all metal and rubber parts in alcohol. Remove rusted or corroded spots from metal areas with crocus or emery cloth. Dry all components with compressed air. Just before reassembly, rewash all metal components coming in contact with hydraulic fluid, in clean alcohol. Dry with compressed air. Use all parts included in repair kit and discard all old rubber parts.

Reassembly — 1) Press new bearing and seal into rear housing. The flat rubber surface of the seal should be 5/16" below flat, inside surface of rear housing.

2) Place reaction disc in hub of front plate with small tip toward hole. Use a rounded rod to seal disc. Place holding mandrel (J-22839) in a vise.

3) Place front diaphragm on front plate with long fold of diaphragm down. Place a suitable seal protector (J-22733) over threads on front plate hub.

4) Apply a light film of silicone lubricant to front plate hub and to seal in center plate. Guide center plate, seal end first, onto front plate hub. Care must be taken not to damage center plate seal. Remove seal protector.

5) Apply a light coat of silicone lubricant to bearing surfaces of air valve plunger. Care must be taken not to get lubricant on rubber grommet inside plunger.

6) Install square ring seal on shoulder of front plate hub. Install valve plunger return spring and plunger in base of front plate hub.

7) Set rear plate over front plate hub. By hand only, screw plate on hub. Make sure valve and spring are correctly aligned. Tighten plates to 150 INCH lbs. by hand. Check plunger travel.

8) Assemble rear diaphragm to rear plate. Place lip of diaphragm in rear plate groove. Install diaphragm retainer over rear diaphragm and lip of center plate. Press retainer until it seats on shoulder of center plate.

Power Brake Units

BENDIX DUAL DIAPHRAGM (Cont.)

- 9) Apply talcum powder to rear housing inside wall. Apply silicone lubricant to scalloped cutouts of front housing and seal in rear housing.
- 10) Install diaphragm and plate assembly into rear housing. Carefully guide rear plate hub through seal in rear housing.
- 11) Bosses on center plate must be aligned between lances in rear housing for reassembly. Work outer rim of front diaphragm into rear housing using a screwdriver. Make sure it is under lances in housing.
- 12) Attach holding fixture (J-22805) to front housing studs. Position front housing and holding fixture in an arbor press.
- 13) Place spanner wrench (J-9504) over studs on rear housing. Bolt wrench to studs. Place piece of pipe used during disassembly over plastic diaphragm plate hub. Place a piece of flat stock over pipe.
- 14) Install return spring so that small end of spring is against housing. Place rear housing over front housing and align scribe marks. Rotate spanner wrench clockwise until housings lock together.
- 15) Bend tabs in 4 deep lances back to original position. Remove spanner wrench and holding fixture.
- 16) Wet poppet valve with denatured alcohol. Install in rear plate hub, small end first. Wet poppet retainer with denatured alcohol and assemble with shoulder inside poppet.
- 17) Install retainer, filters and silencer over ridge on rod. Install return spring over ball end of operating valve rod. Wet grommet in valve plunger with denatured alcohol. Guide air valve rod into valve plunger.
- 18) Tap end of operating valve rod with plastic hammer to lock ball in grommet. Press filters and silencer into hub and install retainer on hub.
- 19) Install silencer in dust boot. Wet boot opening with denatured alcohol. Install over operating rod and rear housing flange. Install new check valve and grommet.
- 20) Apply silicone lubricant to piston end of push rod. Insert in front plate cavity. Twist rod to eliminate air bubbles at reaction disc. Assemble seal over push rod and press into recess in front housing.

ADJUSTMENTS

PUSH ROD ADJUSTMENT

Chevrolet & GMC – 1) Place power unit in a vise with front housing up. Remove front seal to ensure all vacuum is released from unit. Place master cylinder rod, flat end first, in piston rod retainer. Press down on rod with 40 to 50 pounds of pressure to make sure rod is seated.

2) Place a suitable measuring gauge (J-22647) over piston rod and in such a position that it can be moved from left to right without contacting studs. The center section of gauge has two levels. The piston rod should always contact the lower level and never contact the highest level.

- 3) If the push rod does not contact gauge correctly, an adjustable push rod must be obtained. Adjust self locking screw on rod to obtain correct clearance with gauge. Apply silicone lubricant on the inside diameter of front housing seal and place seal in position in housing depression.

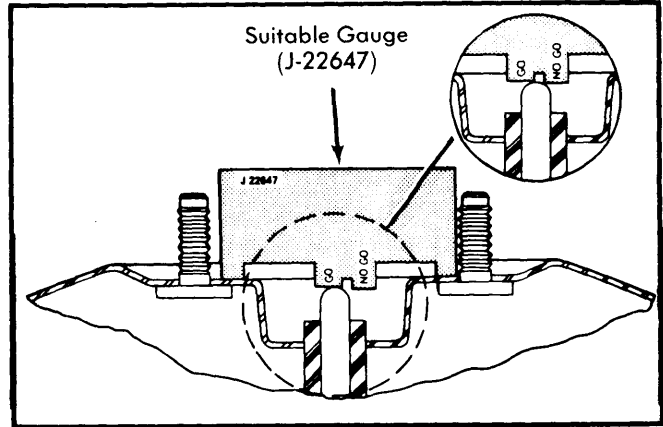

Fig. 3 Checking Push Rod Height Chevrolet and GMC

Dodge & Plymouth – Push Rod length is preset at factory and is non-adjustable.

Ford & IHC – Check distance from outer end of booster assembly push rod to front face of booster. Use a gauge manufactured to specifications. See Fig. 4. Turn push rod screw in or out until specified length is obtained.

Push Rod Length Specifications

Application	Dimension
Ford	
All Models (Exc. E-350)	.980-.995"
E-350	.931-.946"
IHC	
With Drum Brakes	.980-.995"
With Disc Brakes	1.185-1.200"

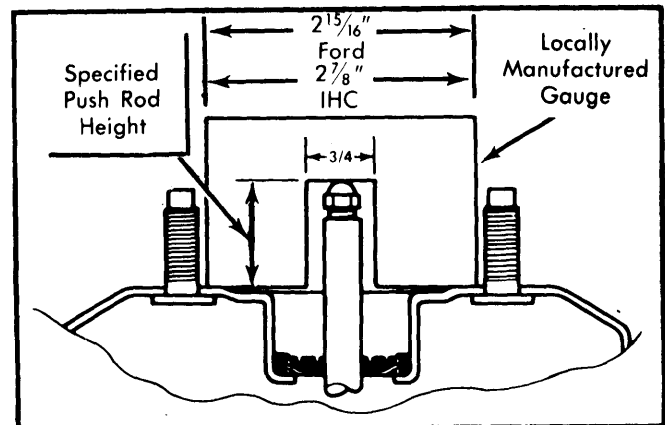

Fig. 4 Checking Push Rod Height Ford and IHC