

BENDIX SINGLE DIAPHRAGM

Chevrolet
Ford
GMC
IHC

DESCRIPTION

Vacuum suspended, self-contained, vacuum-hydraulic unit which utilizes engine manifold vacuum and atmospheric pressure to provide its power. Vacuum power unit contains power piston assembly, which houses control valve, reaction mechanism, and return spring. Control valve consists of air valve, floating control valve assembly, and push rod. Reaction mechanism consists of reaction plate and levers. A vacuum check valve is mounted in front housing for connection to vacuum source.

REMOVAL & INSTALLATION

NOTE — Power brake unit can be removed without removing master cylinder or disconnecting hydraulic lines.

Removal — Disconnect vacuum line from check valve or power unit. Remove nuts securing master cylinder to power unit. Pull master cylinder forward away from unit. Disconnect brake pedal from push rod. Remove power unit-to-firewall bolts and remove unit.

Installation — To install power unit, reverse removal procedure.

OVERHAUL

NOTE — Only Chevrolet and GMC recommend overhaul of power brake unit.

Disassembly — 1) Scribe mark on housings for reassembly. Remove front housing seal and piston rod. Attach assembly to suitable holding fixture (J-22805). Align tool so that check valve in front housing is not damaged. Loosen lock nut and remove push rod clevis and locknut (if equipped). Remove dust boot retainer, dust boot and silencer from diaphragm plate extension.

2) Partially straighten four deepest tabs on rear housing. Place suitable wrench (J-9504) over studs on rear housing and attach with nuts and washers. Press down on wrench and rotate rear housing clockwise to separate. Remove wrench.

CAUTION — Housings are under spring pressure.

3) Remove air filter from diaphragm plate extension. Remove diaphragm from groove in diaphragm plate. Handle diaphragm carefully. Hold diaphragm plate so that push rod is in horizontal position. Depress rod slightly and rotate piston until air valve lock falls from diaphragm plate hub. Remove reaction disc from diaphragm plate bore (use push rod, or suitable tool), to push disc from seat.

CAUTION — Do not chip diaphragm plate.

4) Remove rear shell bearing seal with punch or screwdriver. Remove vacuum check valve and grommet.

CAUTION — Remove rear seal only if a new one is available. Do not reuse old seal.

Cleaning & Inspection — Use only denatured alcohol to clean all metal, plastic, and rubber parts. Blow out all passages, orifices, and valve holes with clean, dry air, and air dry all parts. Slight rust on inside of housing can be polished with crocus cloth or fine emery cloth. There should be no cuts, nicks, or distortion of any rubber part.

Reassembly — 1) Install vacuum check valve grommet (beveled edge on inside), dip check valve in clean, denatured alcohol and install. Install suitable holding fixture (J-22805) on front housing. Install new rear housing seal in center hole, using suitable tool (J-22677) to seat seal in recess (tool bottoms against housing when seal is in place).

2) Assemble diaphragm plate assembly as follows: Lubricate outer diameter of diaphragm plate and extension, valve, and plunger bearing surfaces, and outer edge of valve poppet. Install valve and rod into diaphragm plate extension. Depress push rod slightly and install air valve lock (lock must index and retain air valve). Install rolling diaphragm in diaphragm plate hub groove. Lubricate reaction disc and install disc (use master cylinder push rod to seat disc in diaphragm plate bore). If disc is not fully seated, push rod height will be gauged incorrectly during adjustment procedure.

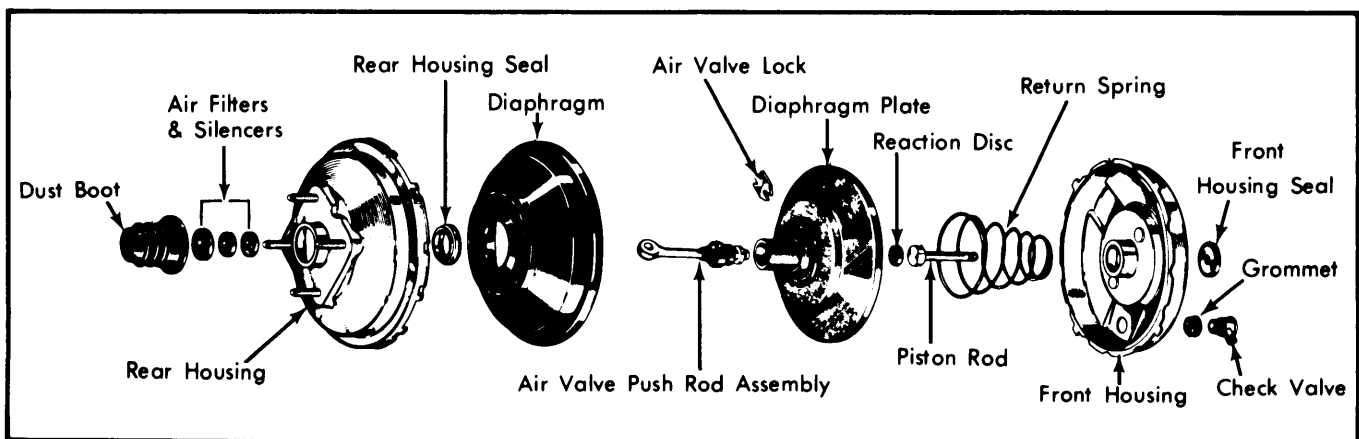

Fig. 1 Exploded View of Bendix Single Diaphragm Assembly

BENDIX SINGLE DIAPHRAGM (Cont.)

3) Lubricate inside of bearing seal and diaphragm bead contact surface of rear shell. Install diaphragm plate assembly in rear housing. Place air filter element over push rod and into diaphragm plate extension. Install filter retainer.

4) With holding fixture in place, position suitable wrench (J-9504) over studs on rear housing and position front and rear housings together. Press down on wrench and rotate rear housing counterclockwise to lock housings. Align scribe marks. Re-bend tabs on rear housings. If tabs are cracked or broken, housing must be replaced. Remove wrench.

5) Install air silencers over push rod end. Install push rod boot and boot retainer. On clevis type push rods, install lock nut and push rod clevis. Lightly lubricate piston rod (except rounded end). Guide rod into center bore until fully seated against reaction disc. Press front housing seal into housing until seal is bottomed in recess of housing.

ADJUSTMENT

PUSH ROD

Chevrolet & GMC – 1) Place power unit in a vise with front housing up. Remove front seal to ensure all vacuum is released from unit. Place master cylinder rod, flat end first, in piston rod retainer. Press down on rod with 40 to 50 pounds of pressure to make sure rod is seated.

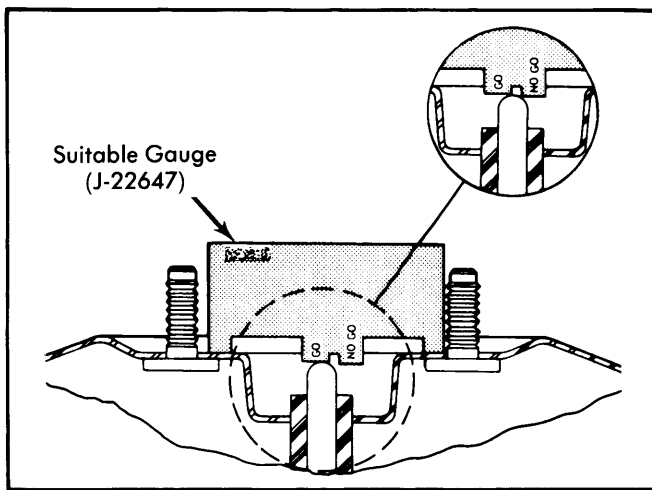

Fig. 2 Checking Push Rod Height Chevrolet and GMC Models

2) Place a suitable measuring gauge (J22647) over piston rod in such a position that it can be moved from left to right

without contacting studs. The center section of gauge has two levels. The piston rod should always contact the lower level and never contact the highest level.

3) If the push rod does not contact gauge correctly, an adjustable push rod must be obtained. Adjust self locking screw on rod to obtain correct clearance with gauge. Apply silicone lubricant on the inside diameter of front housing seal and place seal in position in housing depression.

Ford & IHC – Check distance from outer end of push rod to front face of unit. Use a gauge manufactured to specifications shown in illustration. See Fig. 3. Turn push rod screw in or out until specified length is obtained.

Push Rod Length Specifications

Application	Dimension
Ford (All Models)	.980-.995"
IHC	
All Models W/Drum Brakes	.980-.995"
All Models W/Disc Brakes	1.185-1.200"

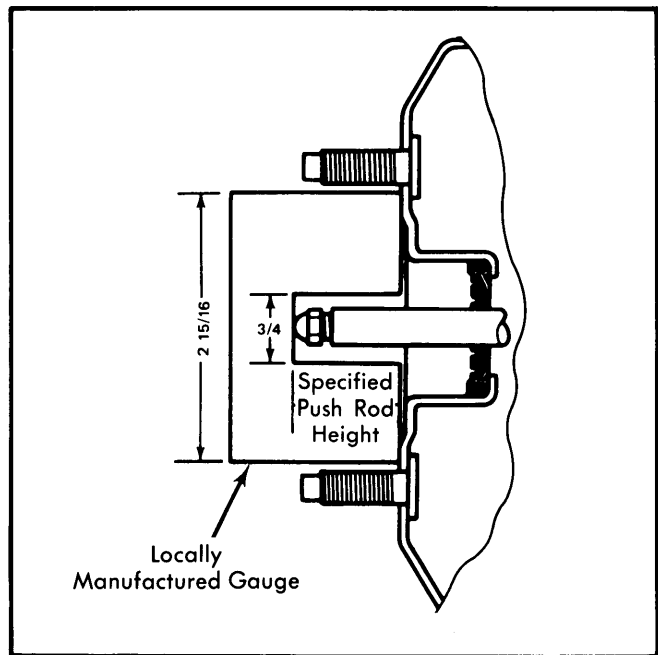

Fig. 3 Checking Push Rod Height Ford and IHC Models