

FORD MOTOR CO. C-11

"F" Models & Bronco

DESCRIPTION

C-11 power steering pump is a belt driven, slipper type integral pump with a fiber glass nylon reservoir. Reservoir is attached to rear side of pump housing front plate. Pump body is encased within reservoir. Hoses are attached with quick disconnect fittings, located below filler neck at outboard side of reservoir. A pressure sensitive identification tag is attached to reservoir filler neck, indicating basic model number.

LUBRICATION, TROUBLE SHOOTING & TESTING

See *Power Steering General Servicing* in this section.

REMOVAL & INSTALLATION

Removal – 1) Loosen adjusting bolt and remove drive belt. Disconnect fluid return line at reservoir and drain fluid. Remove quick disconnect pressure line from pump.

2) Remove bolts from front of pump attaching pump to mounting bracket. Remove bolt from pulley and remove pump.

Installation – 1) Place pump on mounting bracket, install bolts and tighten. Install belt and adjust belt tension. Install pressure and return hoses.

2) Fill reservoir, turn steering wheel from lock-to-lock to bleed system. Check for leaks and recheck fluid level.

OVERHAUL

Disassembly – 1) Drain fluid and remove pump. Install suitable pulley remover tool (T69L-10300-A) on pulley hub. Place tool and pump in vise, hold pump and rotate nut counterclockwise to remove pulley

CAUTION – Do not apply in and out pressure on pump shaft. Possible damage to internal thrust areas may occur.

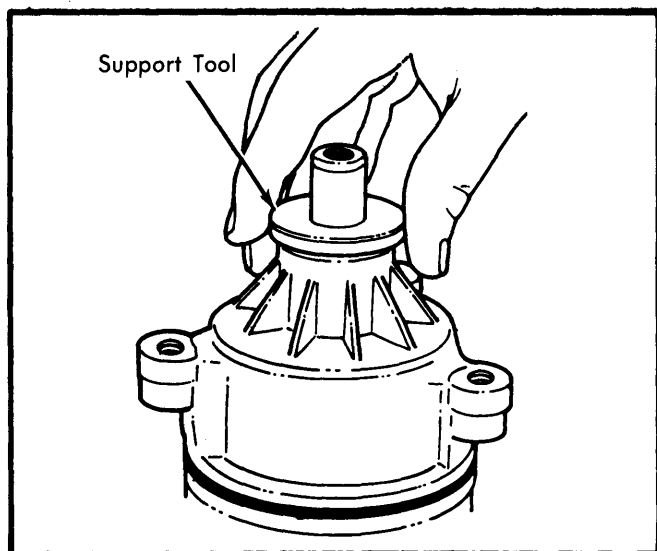

Fig. 1 Installing Lower Support Plate Tool

2) Place pump on suitable tool (T69P-3A674-A) with pulley end of shaft up. Using metal punch, pierce rotor shaft seal and pry out.

3) Remove outlet fitting, flow control valve and spring from pump. Remove pump reservoir. Place lower support plate tool (T78P-3733-A2) over rotor shaft. See Fig. 1.

4) Place pump in "C" clamp with rotor shaft facing down. Install suitable upper compressor plate tool (T78P-3733-A1) between top of clamp and pump and tighten. See Fig. 2.

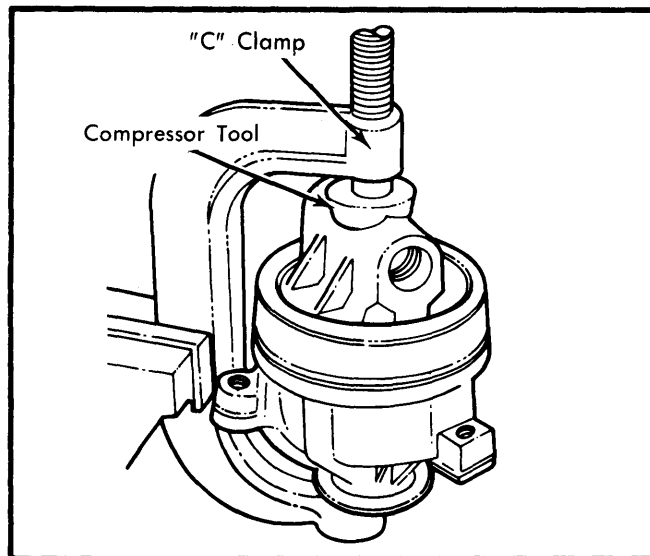

Fig. 2 Installing Compressor Plate Tool

5) Insert small drift through hole in side of pump housing plate and push inward on valve cover retaining ring. Place screwdriver under edge of retaining ring and remove ring.

6) Remove pump from clamp. Remove valve cover and "O" ring seal. Push on rotor shaft and remove. Remove upper plate, rotor and slippers. Remove cam insert and two dowel pins.

7) Remove lower plate and belleville spring by lightly tapping housing on a flat surface, remove "O" ring.

Reassembly – 1) Place rotor on rotor shaft splines, with notches on rotor teeth pointing right. Install retaining ring on end of shaft.

2) Place insert cam over rotor. Ensure recessed flat on insert cam is toward reservoir. Insert spring into rotor spring pocket.

3) Using a slipper to compress spring, install slipper with groove up. Hold cam, turn rotor either direction one space at a time and install spring and slipper.

NOTE – Use caution when turning rotor. Springs and slippers may fall out.

4) Using suitable tool, install rotor shaft seal. Insert dowel pins and belleville spring into housing.

NOTE – Belleville spring must be inserted with dished surface upward.

Power Steering Pumps

FORD MOTOR CO. C-11 (Cont.)

5) Lubricate inner and outer "O" rings with power steering fluid and install. Insert lower pressure plate into pump housing plate over dowel pins.

6) Place assembly in "C" clamp and place suitable driver tool (T78P 3733-A3) into rotor shaft hole. Press on lower plate until it is felt to bottom into pump plate housing.

7) Install cam, rotor and slippers. Install rotor shaft assembly into pump housing plate over dowel pins.

CAUTION — When installing assembly into pump housing plate, step holes must be used for dowel pins. Recessed notch in cam insert must face toward reservoir and be about 180° opposite square pump mounting boss.

8) Place upper pressure plate over dowel pins. Side of plate with square recess notch must face toward reservoir and be positioned about 180° opposite square pump mounting boss.

9) Place "O" ring seal on valve cover, insert valve cover over dowel pins. Ensure outlet fitting hole in valve cover is in line with square mounting boss of pump housing plate.

10) Place assembly in clamp and compress valve cover into pump housing plate until retaining ring groove is shown. Install retaining ring with ends near access hole in housing plate.

11) Remove pump from clamp and install "O" ring seal on pump housing plate. Install power steering reservoir.

12) Install flow control spring and flow control valve into valve cover. Place "O" ring on outlet fitting. Install outlet fitting into valve cover and install pulley.

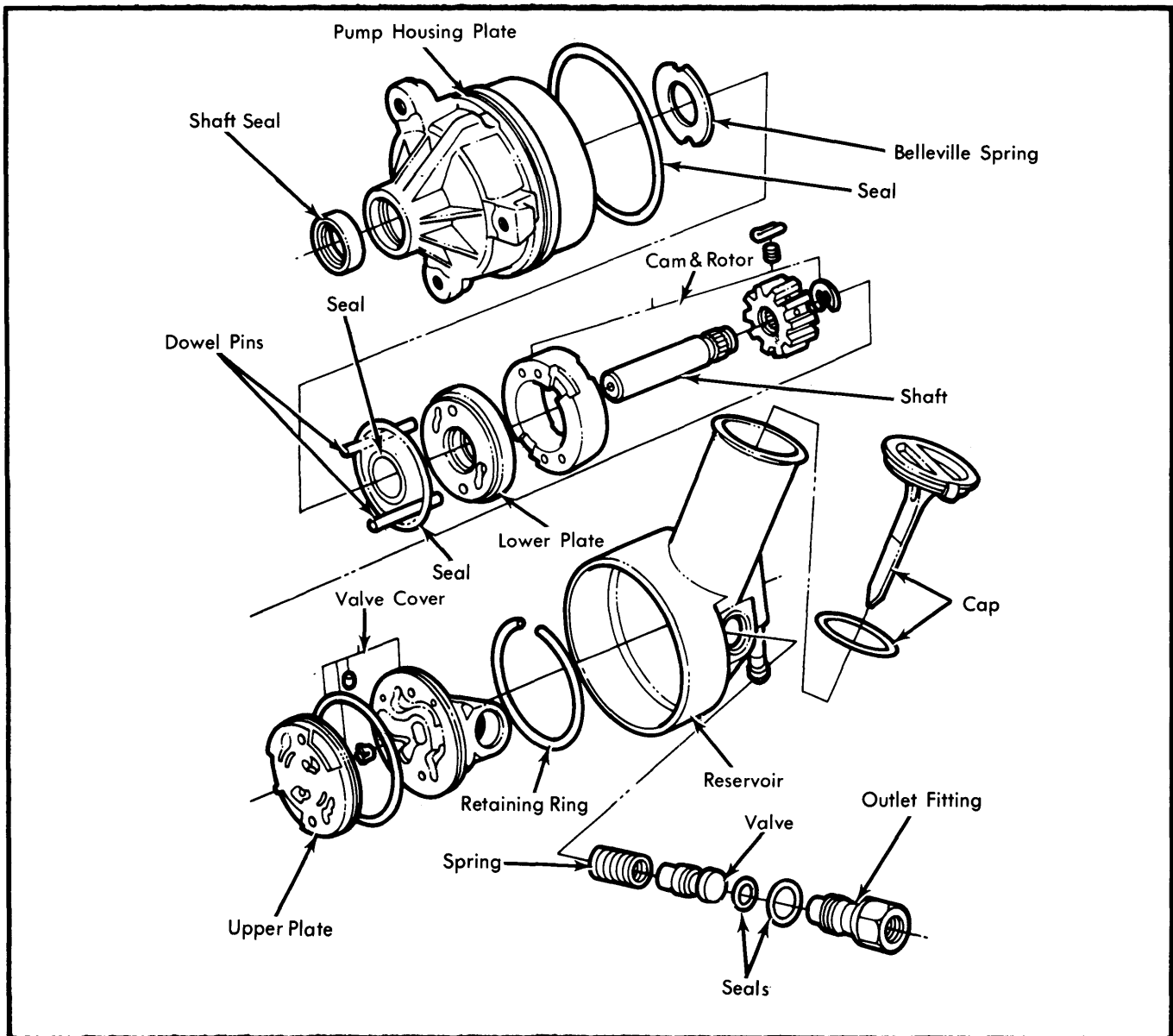

Fig 3 Disassembled View Of C-11 Power Steering Pump