

FORD MOTOR CO. 4-WD COIL SPRING TYPE

F-150
U-150 (Bronco)

DESCRIPTION

Front suspension consists of a driving axle, two coil springs, two radius arms, a side strut bar and two hydraulic shock absorbers (some Bronco models may be equipped with optional dual quad shock absorbers). Radius arms attach to frame side rails and are clamped around axle housing. If vehicle is equipped with optional quad shock absorbers, the front clamp portion of the radius arm is also the lower shock mount. Coil springs are mounted to radius arms directly over axle housing and to brackets attached to frame side rails. Standard equipment shock absorbers attach to frame side rails and radius arms behind coil spring. Optional dual quad shock absorbers mount in front of spring in the same manner. The side strut bar, used to eliminate axle side movement, is attached to left frame rail, and right side of axle housing.

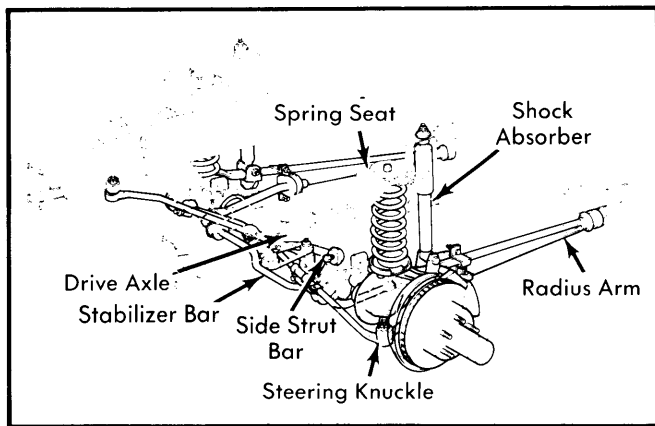

Fig. 1 Identification of Front Suspension Components F-150 and U-150 (Bronco)

ADJUSTMENT

WHEEL ALIGNMENT SPECIFICATIONS & PROCEDURES

See *Wheel Alignment Specifications & Procedures* in **WHEEL ALIGNMENT** Section.

WHEEL BEARING ADJUSTMENT

See *Wheel Bearing Adjustment* in **WHEEL ALIGNMENT** Section.

REMOVAL & INSTALLATION

COIL SPRING

Removal — Raise vehicle and place on safety stands. Raise weight of front axle with jack. Remove lower shock absorber bracket bolt. Remove lower and upper spring retainer bolts. Lower axle with jack to relieve spring tension. Remove spring and lower retainer.

Installation — To install, reverse removal procedure. Tighten nuts and bolts to specifications.

RADIUS ARM

Removal — Raise and support vehicle under frame. Disconnect shock absorber from radius arm, and pull out of the way. Remove lower spring retainer attaching bolts, and remove cotter pin and nut attaching radius arm to frame. Remove radius arm-to-radius arm cap attaching bolts, and remove cap. Move axle housing slightly forward and remove radius arm from vehicle.

NOTE — Radius arm and radius arm caps are a matched set. They are identified by a letter "T" with a number (1 through 100). If there is no "T" identification on either arm or cap, it should not be installed on F-150 models.

Installation — Position rear of radius arm in bracket on frame, and loosely install nut. Position front of radius arm on axle housing, and install radius arm cap with numbers on cap and radius arm together. Install cap attaching bolts, and tighten diagonally in pairs. Position spring and lower spring retainer on radius arm and loosely install bolts. Connect shock absorber to radius arm, and tighten all nuts and bolts.

STEERING KNUCKLE

Removal & Installation — See *Open Steering Knuckle* article in **DRIVE AXLE** Section for steering knuckle removal and installation.

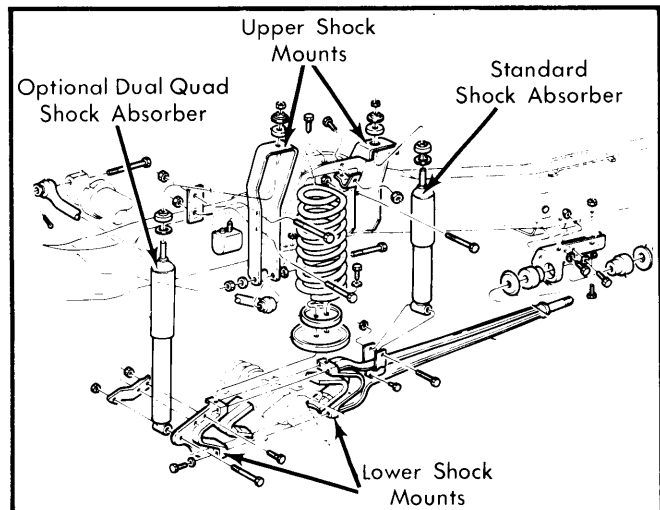

Fig. 2 Identification of Standard and Optional Dual Quad Shock Absorber Components

TIGHTENING SPECIFICATIONS

Application	Ft. Lbs.
Upper Spring Retainer	20-25
Lower Spring Retainer	45-55
Side Strut Bar-to-Frame	119-161
Side Strut Bar-to-Axle	155-205
Radius Arm-to-Bracket	80-120
Radius Arm Cap-to-Radius Arm	90-110
Shock Absorber Mounting Bolt	
Lower	40-60
Upper	15-25