

CHRYSLER CORP. LEAF SPRING TYPE

Dodge - Motor Home Chassis
M300, 400, 500 & 600

DESCRIPTION

Front axles used on Dodge Motor Home Chassis models M300, M400 and M500 are the Elliot type. M600 models use the reverse Elliot type. Axles are mounted to frame by semi-elliptical leaf springs. Steering knuckles are connected to axle by solid, constant diameter kingpins. Both bronze and nylon type bushings are used to provide bearing surfaces for kingpins. Bushings are press fit in axle on Elliot type and press fit in spindle on reverse Elliot type. Hydraulic shock absorbers are double action type, mounted between frame and axle assembly.

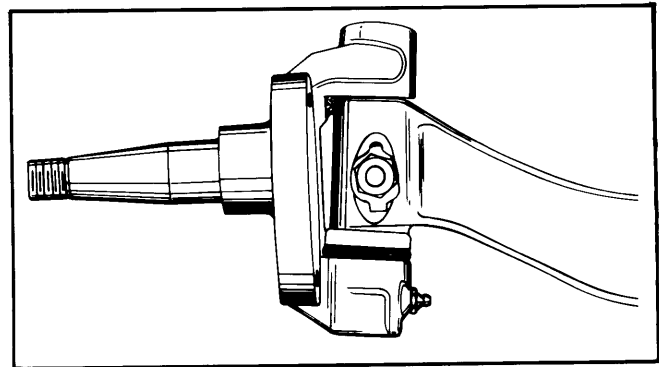

Fig. 2 Reverse Elliot Type Axle End

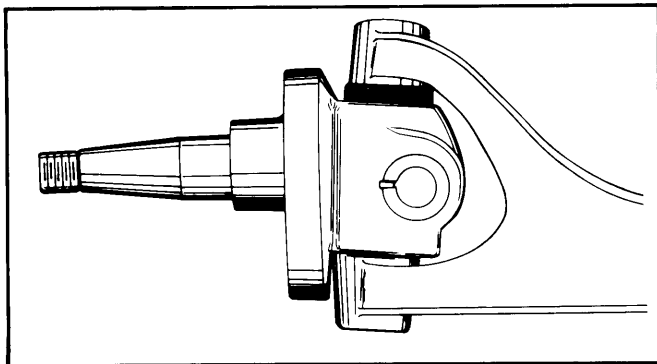

Fig. 1 Elliot Type Axle End

ADJUSTMENT

WHEEL ALIGNMENT SPECIFICATIONS & PROCEDURES

See *Wheel Alignment Specifications & Procedures* in **WHEEL ALIGNMENT** Section.

WHEEL BEARING ADJUSTMENT

See *Wheel Bearing Adjustment* in **WHEEL ALIGNMENT** Section.

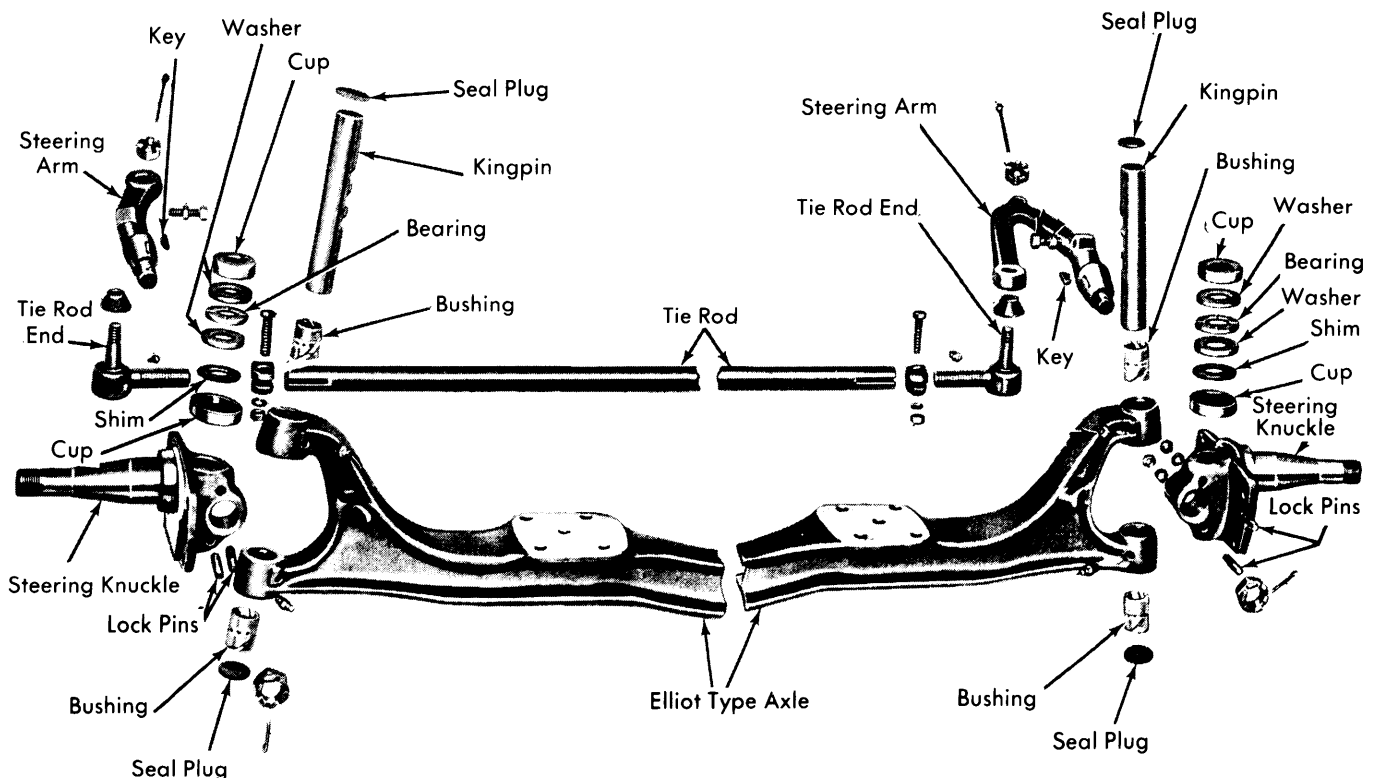

Fig. 3 Exploded View of Elliot Type Front Axle Assembly

Front Suspension

CHRYSLER CORP. LEAF SPRING TYPE (Cont.)

REMOVAL & INSTALLATION

STEERING KNUCKLE

Removal (Elliot Type) — Raise vehicle and support under frame with safety stands. Remove wheel and tire assembly. Remove disc brake caliper without disconnecting brake line. Wire caliper up out of way. Remove rotor and hub assembly. Remove brake caliper mounting adapter. Remove steering arm from steering knuckle. Remove kingpin lock. Remove upper kingpin grease plug. Drive kingpin out and down, driving out lower grease plug. Remove steering knuckle and thrust bearing.

Installation — To install, reverse removal procedure. Make sure flat portions of kingpins are aligned with lock holes. Install new grease seal plugs, and stake into axle at four points around seal plugs.

Removal (Reverse Elliot Type) — Raise vehicle and support under frame with safety stands. Remove wheel and tire assembly. Remove disc brake caliper without disconnecting brake line. Wire caliper up out of way. Remove rotor and hub assembly. Remove brake caliper mounting adapter.

Disconnect tie-rod end at steering knuckle. Remove kingpin lock. Remove upper kingpin grease plug. Drive kingpin out and down, driving out lower grease plug. Remove steering knuckle, thrust bearing, and shim.

Installation — To install, reverse removal procedure. Install new grease seal plugs, and stake into steering knuckle at four points around seal plugs.

KINGPIN BUSHINGS

Removal — **NOTE** — Nylon type bushings are not serviced, if bushings are found defective, replace with bronze type bushings. Nylon type bushings are easily removed by hand. To remove bronze bushings, use a suitable bushing removal and installation tool (C-328A). Remove upper bushing through top and lower bushing through bottom.

Installation — Install bushings using same tool as used for removal. Make sure grease holes in bushings are aligned with grease holes in axle. Ream bushings to obtain .002" clearance with kingpin. Inspect kingpin, if pitted or worn, it must be replaced. Fill grease grooves in bushings with chassis lubricant and install steering knuckle as previously outlined.

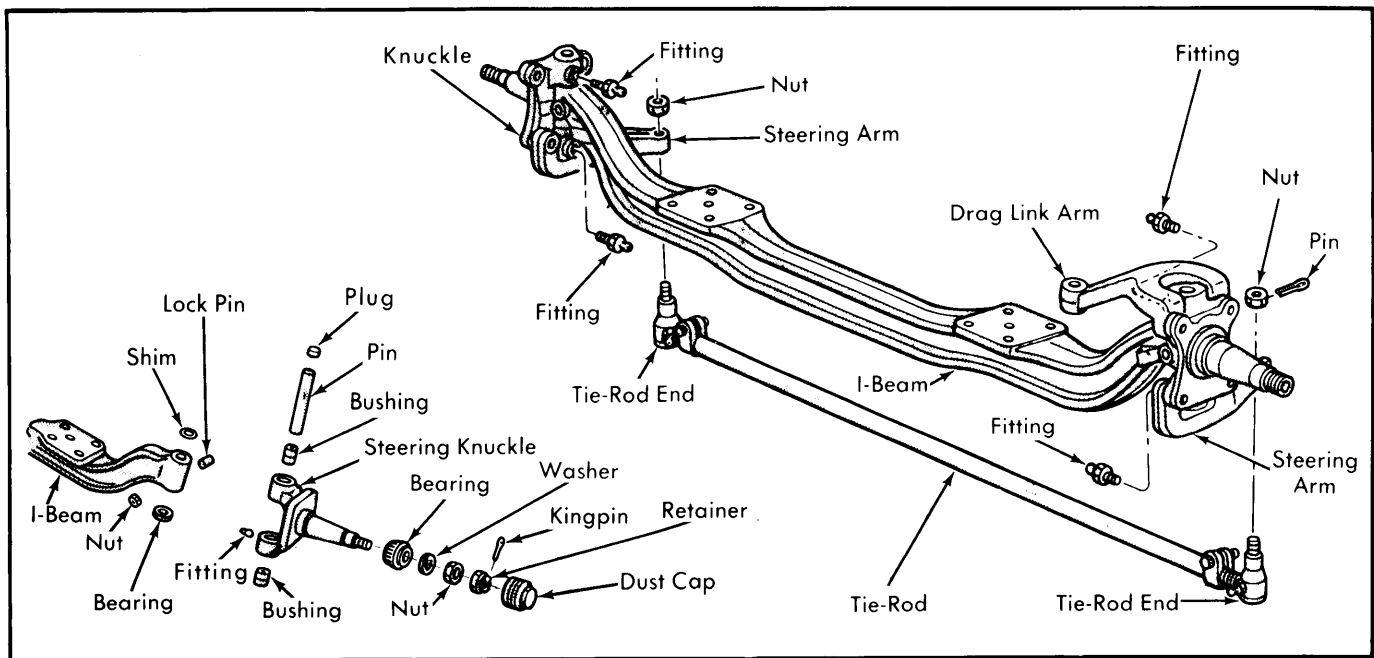

Fig. 4 Exploded View of Reverse Elliot Type Front Axle Assembly