

## CHRYSLER CORP. SLIDING CALIPER DISCS

Dodge (All Models)  
Plymouth (All Models)

### DESCRIPTION

Chrysler vehicles (except "M" Models) are equipped with single piston, sliding caliper disc brakes. "M" Models use a two piston sliding caliper disc brake. Except for number of pistons and component attachment, operation and service procedures are essentially the same. Brake assembly consists of hub and disc assembly, caliper, disc pads, splash shield and adaptor. Cooling fins are cast integrally between machined braking surfaces. When brake pedal is depressed, hydraulic pressure is applied against brake caliper piston(s). This force is transmitted to inboard brake pad and inner surface of rotor. As force increases against inboard side, caliper slides inward on machined anchor plate ramps, providing vise-like clamping action on rotor.

### ADJUSTMENT & SERVICING

#### DISC PAD ADJUSTMENT

Pad wear is automatically compensated for by piston moving outward in cylinder bore; therefore, no disc pad adjustment in service is required. **NOTE** — Inspect condition of disc pads whenever wheels are removed. If any pad shows signs of excessive wear, replace complete disc pad set.

#### BLEEDING SYSTEM

See Hydraulic Brake Bleeding in this Section.

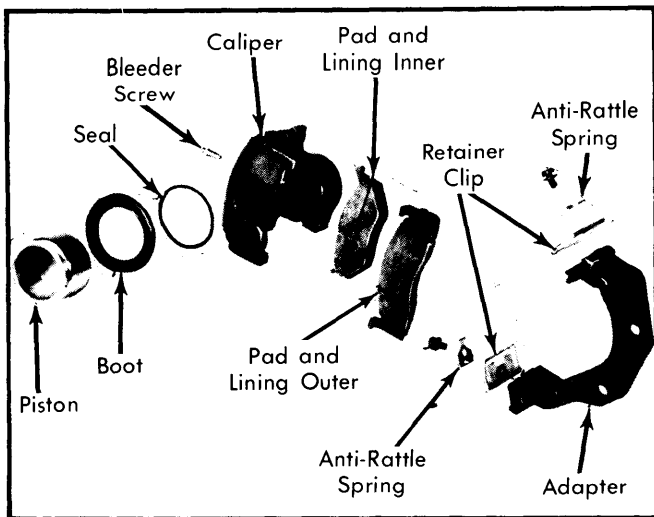

Fig. 1 Exploded View of Chrysler Single Piston Disc Brake Caliper

### REMOVAL & INSTALLATION

#### DISC BRAKE PADS

**Removal, W200 (W/Spicer 60 Front Axle) & W300** — Siphon fluid from master cylinder until cylinder is 1/3 full. Raise and support vehicle, and remove wheel and tire. Using a

"C" clamp, bottom caliper piston in cylinder bore. Remove clamp. Remove key retaining screws and drive out caliper support key with a brass punch. Remove caliper support spring and remove caliper from adapter, but do not let caliper hang from brake line. Pry outer disc pad from caliper and remove inner disc pad and anti-rattle spring from adapter. If disc pads are not being replaced, mark or identify to ensure that they are installed in original position.

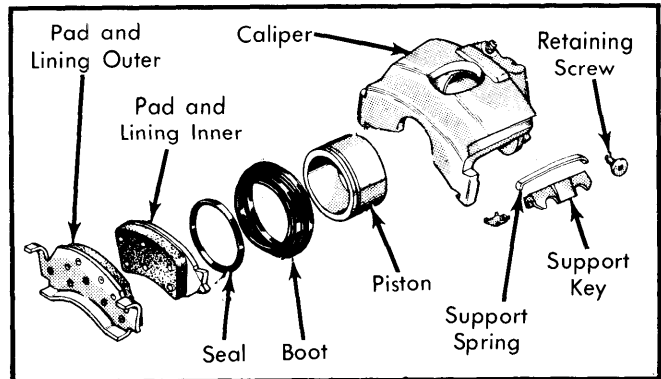

Fig. 2 Exploded View of Bendix Single Piston Disc Brake Caliper

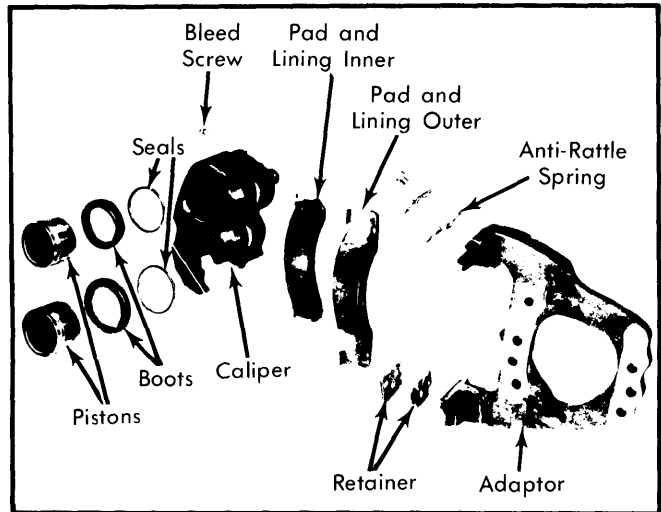

Fig. 3 Exploded View of Chrysler Two Piston Disc Brake Caliper

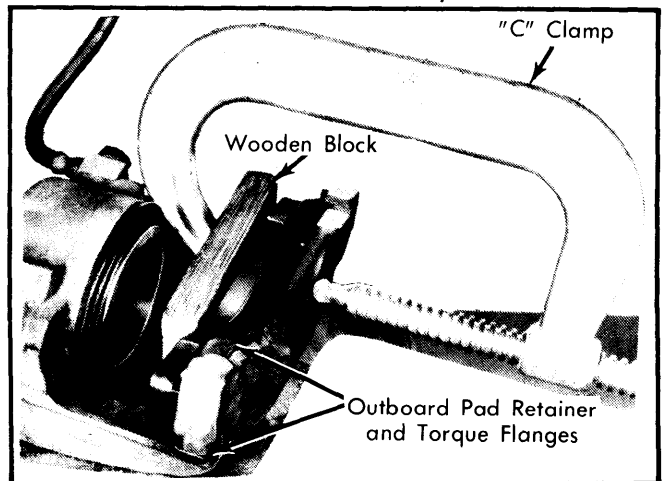

Fig. 4 Installation of Outboard Pad and Liner

## CHRYSLER CORP. SLIDING CALIPER DISCS (Cont.)

**Installation** — Install anti-rattle spring and inner disc pad in adapter, making sure clips remain in position. Place outer disc pad in position in caliper. If disc pad cannot be installed by hand, press into place using a block of wood and a "C" clamp. Position brake caliper on adapter, making sure hose is not twisted. Position spring over caliper key and install between adapter and lower caliper machined surface. Tap into place using a brass punch and hammer. Install retaining screw, making sure boss on screw fits fully into cut-out on key. Install wheel and tire and refill reservoir in master cylinder to within  $\frac{1}{4}$ " of top of reservoir. Pump brake pedal several times and recheck fluid level.

**Removal (All Remaining Models)** — Raise and support vehicle. Remove wheel and tire. Remove caliper retainer and anti-rattle spring assemblies. Carefully lift caliper assembly out and away from rotor. Pry between outer disc pad and fingers of housing to remove outer pad. Support caliper to prevent damage to brake line and remove inner disc pad.

**Installation** — Slowly push piston(s) back into caliper. Care must be taken to ensure that reservoir does not overflow while pushing in on piston. Slide outer disc pad into caliper. There should be no free play between disc pad flange and caliper flange. If free play is found, bend disc pad flange until interference fit with caliper is obtained. If necessary install disc pad using a "C" clamp and a block of wood placed across disc pad. Place inner lining on adapter with disc pad flanges aligned with flange ways in adapter. Slide caliper into position in adapter and over disc. Align caliper on adapter taking care not to pull dust boot away from groove in piston. Install anti-rattle springs and retaining clips, and tighten retaining screws. Pump brake pedal several times until a firm pedal is obtained. Recheck fluid level in master cylinder reservoir.

### BRAKE CALIPER

Brake caliper removal and installation procedures are same as for disc brake pads, except it will be necessary to disconnect hydraulic brake hose at caliper.

### DISC ROTOR

**Removal (2-WD Models)** — 1) Raise vehicle and support on safety stands. Remove brake caliper without disconnecting brake line as previously outlined.

2) Remove grease cover from end of hub. Remove cotter pin, nut lock, nut, thrust washer and outer wheel bearing. Pull rotor and hub off wheel spindle.

**Installation** — Slide rotor and hub into position on spindle. Install nut and adjust wheel bearing. See *Wheel Bearing Adjustment* in WHEEL ALIGNMENT Section.

**Removal (4-WD W/Model 44FBJ Front Axle)** — Raise vehicle and support on safety stands. Remove brake caliper without disconnecting brake line as previously outlined.

2) Remove grease cover from end of hub. Remove cotter pin, outer axle shaft nut and washer. Position a suitable wheel puller (C-4358) on wheel studs in hub.

3) Install and tighten 3 wheel lug nuts on puller. Tighten puller screw until rotor and hub are pulled off axle shaft. Remove rotor and hub and remove puller. See Fig. 5.

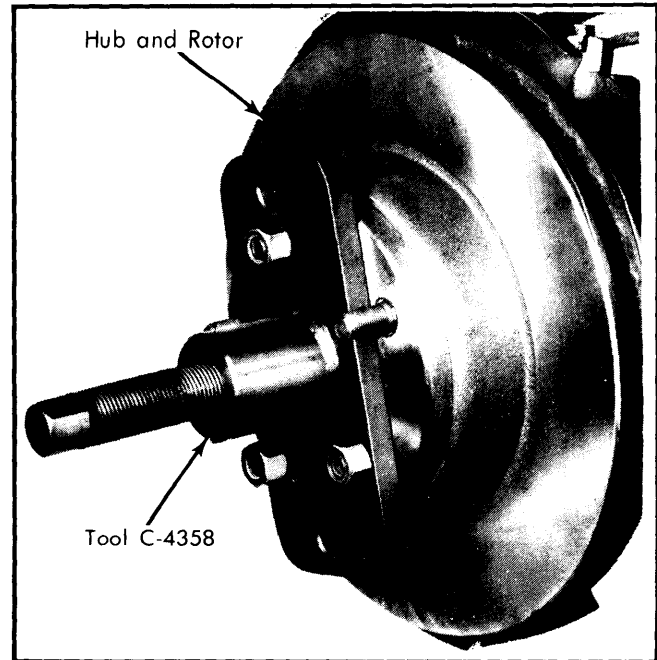

**Fig. 5 Removing Rotor Hub (44FBJ Axle)**

**NOTE** — Bearing retainer must be removed from steering knuckle if inner bearings are being removed. Special tools and procedures are required for removal and installation of inner wheel bearings. See *Front Axle Shafts and Bearings* in the *Dana/Spicer Full-Floating Axle* Article in the *Drive Axle* Section. The following installation procedure is after inner bearings and retainer have been installed in rotor hub.

**Installation** — 1) Install rotor and hub assembly on steering knuckle. Tighten bearing retainer bolts, through access hole in hub, to 30 ft. lbs. in a criss-cross pattern. Install axle shaft washer and nut and adjust wheel bearing. See *Wheel Bearing Adjustment* in WHEEL ALIGNMENT Section.

**Removal (4-WD W/Model 60 Front Axle)** — 1) Raise vehicle and support on safety stands. Remove brake caliper without disconnecting brake line as previously outlined.

2) Remove grease cover from end of hub. Remove snap ring from drive axle. Remove flange bolts and flange from hub.

3) Straighten lock tabs on outer wheel bearing lock ring. Using a suitable socket (DD-1241-JD) remove outer lock nut, lock ring, inner nut and outer wheel bearing. Remove rotor and hub assembly.

**Installation** — 1) Install rotor and hub in position on spindle. Install outer bearing and inner lock nut and adjust wheel bearing. See *Wheel Bearing Adjustment* in WHEEL ALIGNMENT Section.

## OVERHAUL

### BRAKE CALIPER

**Disassembly** — 1) Raise vehicle off floor and remove wheel. Remove retainer and anti-rattle spring assemblies. Carefully slide caliper out and away from rotor and support assembly on axle and steering linkage.

## CHRYSLER CORP. SLIDING CALIPER DISCS (Cont.)

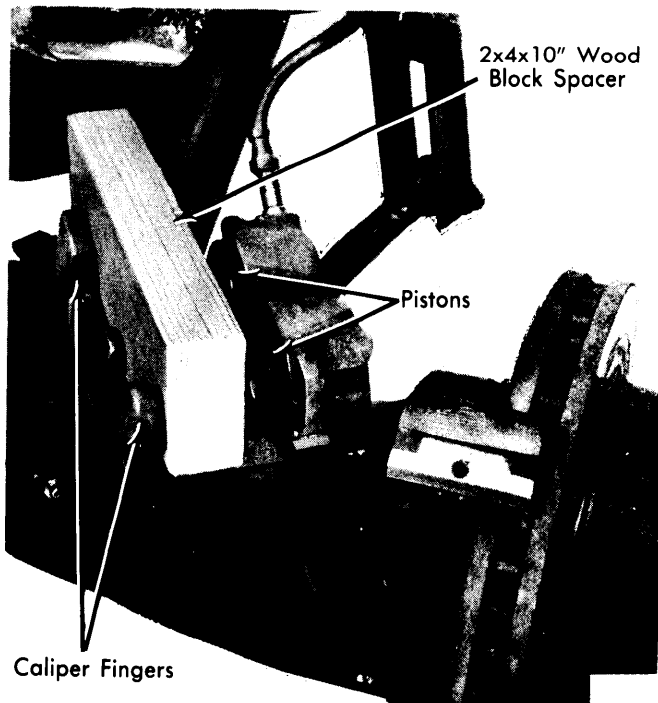

Fig. 6 Removing Caliper Pistons

2) On vehicles equipped with single piston caliper, carefully depress brake pedal to hydraulically push piston out of bore in caliper. Pedal will fall away when piston has passed bore opening. Prop pedal in any position below first inch of travel to prevent fluid loss.

3) On vehicles equipped with double piston calipers, place spacer between caliper fingers and pistons. Carefully depress brake pedal until both pistons contact spacer. Remove pistons and prop pedal in any position below first inch of travel to prevent fluid loss.

**CAUTION** — Under no conditions should air pressure be used to remove piston(s) from bore(s).

4) Disconnect brake hose and remove caliper from vehicle. Remove dust boot and piston seal. **NOTE** — Use wooden or plastic rod to work seal out of groove in piston bore to prevent damage to cylinder.

**Inspection** — Clean all parts with alcohol and blow dry with compressed air. Inspect piston bore for scoring or pitting; light scratches or corrosion can be removed by honing, providing bore diameter is not increased more than .002". Discard used piston seal(s) and boot(s).

**Reassembly** — Dip piston seal(s), dust boot(s), and piston(s) in suitable assembly lubricant. Work piston seal(s) into groove in bore(s) until fully seated. Install dust boot(s) into outer groove of cylinder bore. **NOTE** — Boot will snap into place when properly positioned. Plug high pressure inlet to caliper and bleeder screw hole. Insert piston(s) squarely into bore(s) and press against piston(s) until boot(s) is forced into groove around piston(s). Remove plugs and bottom piston(s) in bore(s).

### DISC ROTOR

Mount dial indicator on steering arm with contact tip of in-

dicator against braking surface, approximately one inch from edge of rotor. Temporarily adjust wheel bearings to zero end play, place a large flat washer over each wheel mounting stud, install nuts and tighten. Measure lateral runout on both sides of rotor. Using micrometer, measure rotor thickness at twelve equally spaced locations around rotor, approximately one inch from edge. If rotor is not within specifications, or is scored or warped, refinish or replace as necessary. **CAUTION** — If rotor is to be refaced, do not remove more than .015" of material from each side of rotor.

### PLYMOUTH BRAKE SPECIFICATIONS

Application	Dimension
Rotor Thickness	
PB100 & 200.....	1.25"
PW & PD100.....	1.25"
PB300.....	1.19"
Rotor Thickness Variation.....	.0005"
Lateral Rotor Runout.....	.004"

### DODGE BRAKE SPECIFICATIONS

Application	Dimension
Rotor Thickness	
D & W100.....	1.25"
B100 & 200.....	1.25"
AW & AD100.....	1.25"
D & W200 & 300.....	① 1.19"
B & M300.....	1.19"
M400, 500 & 600.....	1.55"
Rotor Thickness Variation	
M400, 500 & 600.....	.0008"
All Others.....	.0005"
Lateral Rotor Runout	
M400, 500 & 600.....	.005"
All Others.....	.004"

① — Thickness is 1.25" on D200 models with 3300 lb. front axle.

### TIGHTENING SPECIFICATIONS

Application	Ft. Lbs.
Caliper Adapter Bolts	
D & W100 & 200.....	100
B & PB100 & 200.....	100
AD & PD100.....	100
AW & PW100.....	110
D & W200 & 300①.....	160
B & PB300.....	160
M300	
Bolt.....	115
Nut.....	90
M400, 500 & 600.....	110

① — D200 is heavy duty model.