

BENDIX/DELCO-MORAINÉ DUAL PISTON MASTER CYLINDER

Chevrolet
Dodge
GMC
International Harvester
Jeep
Plymouth

NOTE — Some models may use other units; see Brake Systems Index.

DESCRIPTION

Bendix and Delco-Moraine tandem dual piston master cylinders are single casting type with front and rear pistons and a separate reservoir and outlet for each piston. Rear piston is operated by push rod connected to brake pedal. Front piston is operated by rear piston. In a combination drum and disc brake system, reservoir which feeds disc brakes is larger to correspond with larger size of disc brake caliper cylinder. Disc brake outlet has no residual valve since disc brakes must not have any residual pressure. Master cylinder outlet which feeds drum brakes has a residual valve under tube seats. Failure in either front or rear system does not result in failure of entire system.

NOTE — On Chrysler Corp. Motor Home Chassis models, residual valve is located in rear brake line outlet at Brake Warning Light/Hydraulic Control Valve.

ADJUSTMENT

BRAKE PEDAL

NOTE — Adjustment for vehicles equipped with power boosters is accomplished at power booster. See Power Brake Units in this Section.

All Models — Vehicles without power assisted brakes incorporate a non-adjustable push rod. Brake pedal push rod length is preset by manufacturer.

REMOVAL & INSTALLATION

MASTER CYLINDER

Removal — Disconnect front and rear hydraulic brake lines at master cylinder, and cover ends to prevent entry of foreign matter. On vehicles without power assist units, disconnect brake pedal push rod at brake pedal. Remove master cylinder attaching bolts, and remove cylinder assembly from vehicle.

Installation — Position master cylinder on vehicle and install cylinder attaching bolts. Connect front and rear hydraulic brake lines to cylinder. Connect brake pedal push rod, if removed. Fill reservoir with clean brake fluid, and bleed hydraulic system. See *Hydraulic Brake Bleeding* in this Section.

OVERHAUL

MASTER CYLINDER

Disassembly — 1) Remove master cylinder cover and diaphragm, and drain fluid from reservoirs. Stroke piston to force residual fluid out through outlet ports. Remove piston stop bolt from housing, and remove retainer ring from groove in end of cylinder bore.

2) Remove both piston assemblies, then remove any internal parts remaining in cylinder bore. Remove and discard all rubber parts from piston assemblies.

3) Enlarge hole in tube seat using $\frac{13}{64}$ " drill. Tap out seats with a $\frac{1}{4}$ "x20 tap. Install spare tube nut in outlet hole. Place a flat washer on a one inch long $\frac{1}{4}$ "x20 screw, and thread screw through tube nut into seat. While holding screw to prevent it from turning, back tube nut out of outlet. Remove residual check valve and spring from outlet. **NOTE** — On some models it may be easier to remove tube seats using an easy out or a self-threading screw.

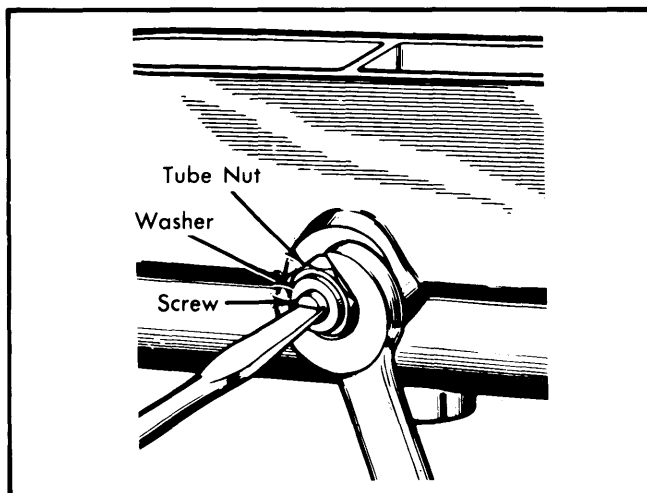

Fig. 1 Removing Tube Seat from Master Cylinder

Inspection — Inspect cylinder bore for scoring or corrosion. Staining which has not pitted or roughened surface of cylinder bore may be removed with crocus cloth. If cylinder bore is scored, pitted, or corroded, General Motors and Jeep recommend replacing cylinder assembly. Chrysler Corp. permits honing bore, providing bore diameter is not increased more than .002". IHC allows honing, if piston-to-bore clearance does not exceed .005" after honing.

Reassembly — 1) Place residual valve spring in drum brake outlet(s) of cylinder. Position residual valve on top of spring and insert tube seat in outlet against valve. Thread a spare tube nut into outlet and tighten to bottom tube seat in bore. Remove nut and inspect for burrs or shavings caused by installing seat(s).

2) Install new secondary cups on rear of front (secondary) piston, with cup lips facing away from each other. Some front pistons use a cup in rear groove and an "O" ring in the second groove from the rear, with cup lip facing the rear. Install protector washer, if equipped, over front of secondary piston and install primary cup, with lip facing forward and back of cup against protector washer. **NOTE** — Protector washer may be permanently attached to piston.

3) Install new primary seal protector and primary seal on end of rear (primary) piston, with flat side of seal against protector, and protector against flange of piston having compen-

BENDIX/DELCO-MORAINE DUAL PISTON MASTER CYLINDER (Cont.)

sating holes. Assemble spring retainer in one end of piston and secondary piston stop in opposite end. Place spring over end of rear piston, with retainer seat inside lips of primary seal. Insert extension screw through front piston stop and primary spring retainer and tighten until bottomed.

4) Coat bore of cylinder and all cups with clean brake fluid, then insert secondary piston spring retainer into secondary piston spring. Position retainer and spring over end of secondary piston until retainer seats inside lips of primary cup.

5) Hold cylinder with open end up and insert front piston into cylinder bore until spring seats against end of cylinder. Insert rear piston assembly, spring end first, into master cylinder bore. Install rear piston stop and retainer. Push rear piston down in bore and install front piston stop screw and gasket.

CAUTION — Stop screw is a special screw. Do not substitute with any other type.

6) Position master cylinder in a vise, attach bleeding tubes to cylinder, and fill reservoirs with fluid so that ends of tubes are covered. See *Illustration*. Tubes attached to disc brake outlet(s) must have residual valve placed on end of tube to prevent fluid from siphoning. Stroke piston in bore several times until no air bubbles appear at ends of tubes. Remove bleeding tubes and plug outlets to prevent fluid from draining.

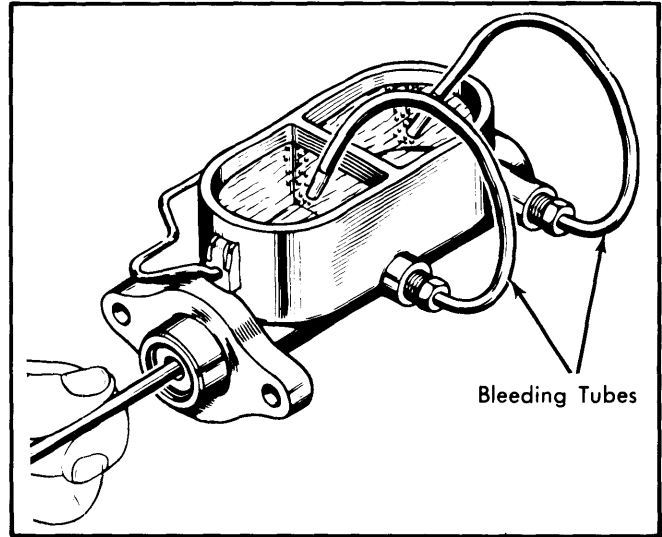

Fig. 2 Master Cylinder Bleeding Procedure

7) Install master cylinder cover and diaphragm. On vehicles without power assist units, assemble brake pedal push rod through retainer, if used, and push retainer over end of master cylinder. Install new dust boot over push rod, and press boot down over retainer.

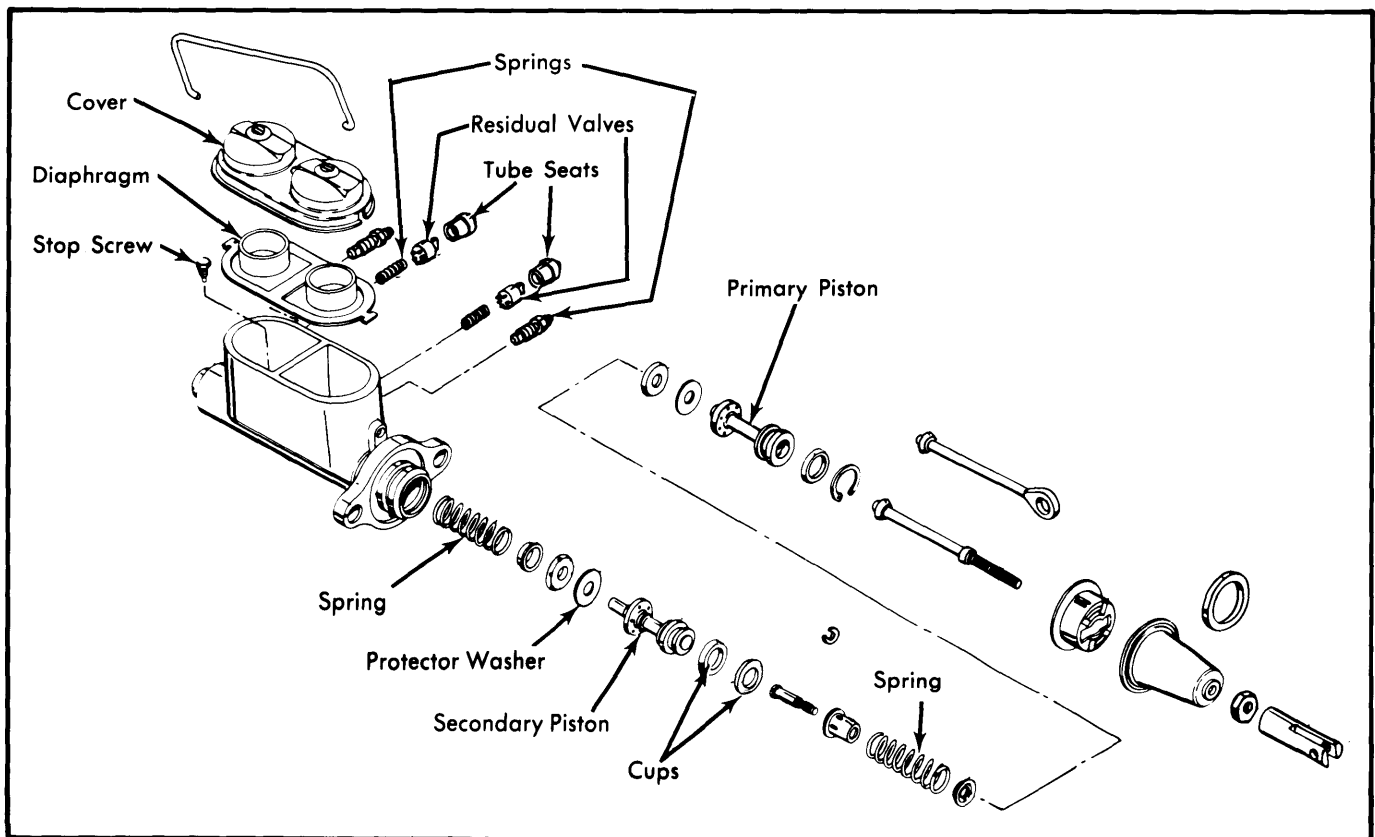

Fig. 3 Exploded View of Delco-Moraine Master Cylinder (Typical)

Master Cylinders

BENDIX/DELCO-MORAINE DUAL PISTON MASTER CYLINDER (Cont.)

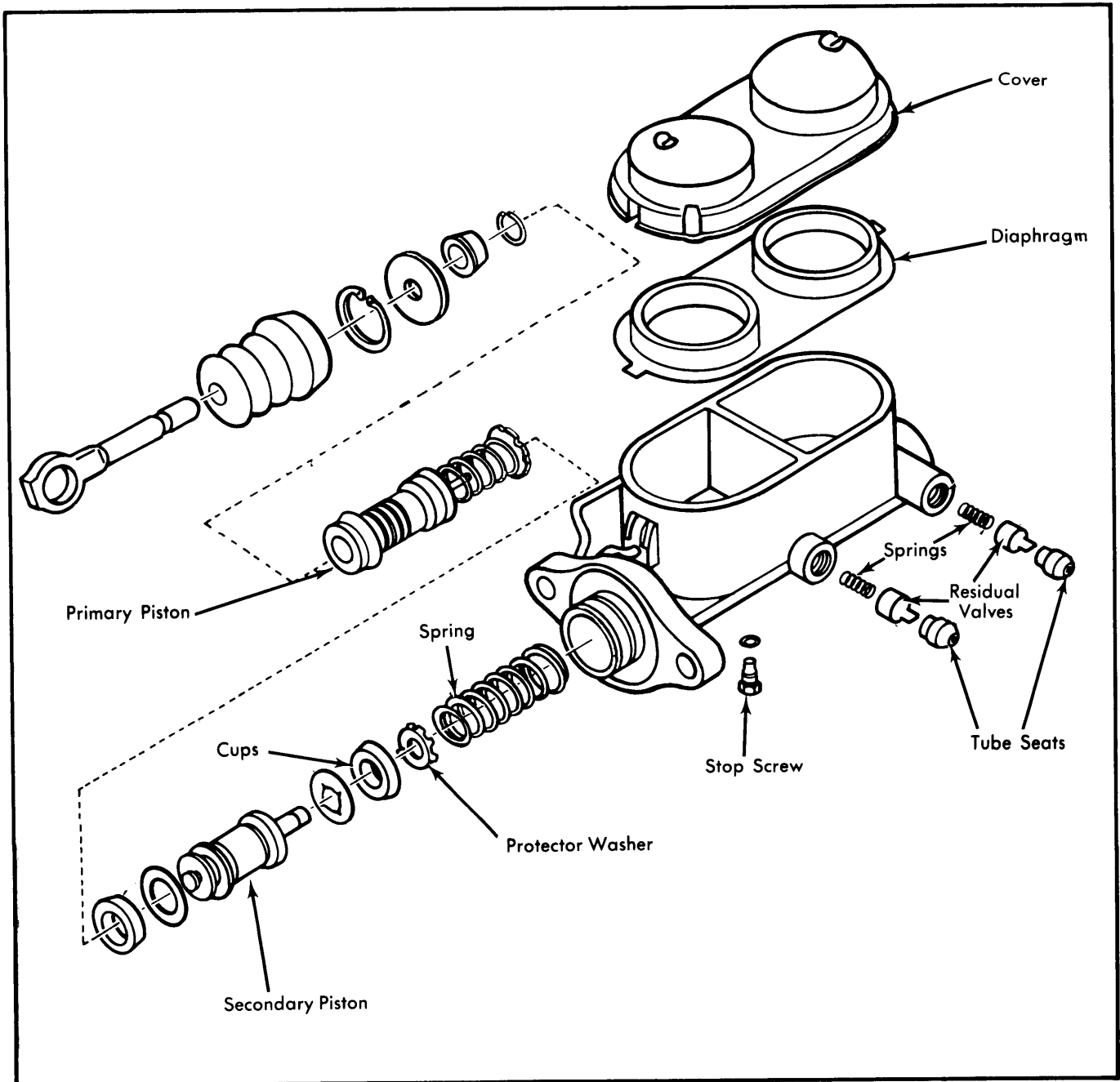

Fig. 4 Exploded View of Bendix Master Cylinder (Typical)