

## FORD MOTOR CO. TORSION BAR

Ford  
F100/F350 (2-WD)  
F150/F250 (4-WD)  
Bronco

### DESCRIPTION

Torsion bar type power steering unit consists of a worm and one-piece rack-piston, which is meshed to gear teeth on sector shaft. Hydraulic control valve, input shaft, and torsion bar assembly are mounted to end of worm shaft and operated by twisting action of torsion bar. One-piece rack-piston, worm and sector shaft are mounted in one housing, while valve spool is mounted in an attached housing. This allows internal passage of fluid between valve and cylinder, thus eliminating the need for all external lines and hoses, except for pressure and return hoses between pump and gearbox assembly.

### LUBRICATION

Check fluid level in pump reservoir every 5000 miles. Steering gear and fluid must be at normal operating temperature. If necessary, add Power Steering Fluid to bring level to proper mark on dipstick.

### ADJUSTMENT

#### OVERCENTER POSITION

Disconnect pitman arm from sector shaft. Disconnect fluid return line at pump reservoir, and cap reservoir return line pipe. Place end of return line in clean container and cycle steering wheel in both directions several times to discharge all

fluid from steering gearbox. Remove horn button from steering wheel, and turn steering wheel until positioned 45° from left steering stop. Using an INCH-lb. torque wrench on steering wheel attaching nut, measure force required to turn steering shaft 1/8 turn from 45° position. Turn steering wheel back to center position, and measure force required to move steering shaft back and forth across center position. Loosen lock nut and turn adjusting screw until reading across center position is 11-12 INCH lbs. greater than reading across 45° position. Tighten lock nut while holding adjusting screw in place.

### TESTING

#### VALVE SPOOL CENTERING

Install a suitable 0-2000 psi pressure gauge and valve assembly between power steering pump and high pressure line. Open gauge valve completely, and remove horn button from steering wheel. Attach an INCH-lb. torque wrench to steering wheel attaching nut. With power steering fluid at normal operating temperature and correct level, steering wheel in centered position, and engine at normal operating temperature, set engine idle to 1000 RPM. Using torque wrench, rotate steering shaft to either side of center to obtain gauge reading of 250 psi in each direction. Torque reading should be same in both directions when 250 psi is reached. If difference between readings exceeds 4 INCH lbs., steering gear must be removed and the shaft and control assembly replaced. **NOTE** — When performing test off vehicle, use same procedure except take torque and pressure readings at right and left stops rather than either side of center.

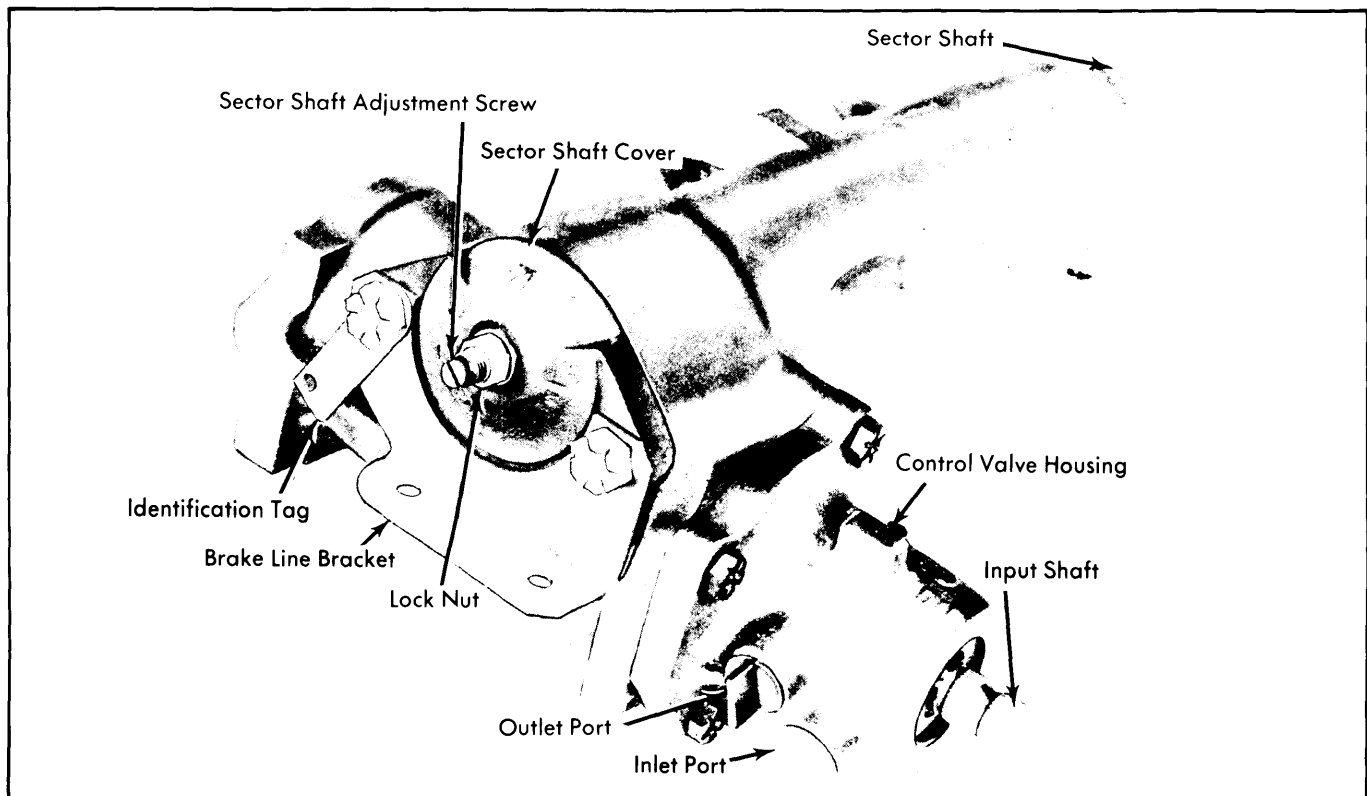

Fig. 1 Ford Torsion Bar Steering Gear Assembly

# Power Steering Gears

## FORD MOTOR CO. TORSION BAR (Cont.)

### REMOVAL & INSTALLATION

#### STEERING GEAR

**Removal** — 1) On F100-F350 and Bronco, disconnect hydraulic lines at power steering gear, and cap lines. Plug ports in steering gear to prevent entry of foreign matter. Disconnect brake lines from bracket steering gear. Remove bolts attaching flex coupling to steering gear and to steering column. Raise vehicle, and remove pitman arm-to-sector shaft lock nut. Using suitable puller, remove pitman arm from sector shaft while being careful not to damage seals.

2) Remove clutch fork return spring to provide clearance for gearbox removal on vehicles with manual transmission. Support gearbox, and remove attaching bolts. Work gear free of flex coupling, and remove gearbox assembly from vehicle. Remove flex coupling from input shaft (if necessary).

**Installation** — 1) Slide flex coupling into position on steering shaft assembly and turn steering wheel so spokes are in horizontal position. Center steering gear input shaft. Install gearbox input shaft into flex coupling and into place on frame. Install and tighten attaching bolts.

2) With wheels in straight ahead position, install pitman arm on sector shaft. Install washer and nut to pitman arm and tighten. Move flex coupling into position on input shaft and steering column, then install and tighten attaching bolts. Connect hydraulic lines, and reinstall brake lines to bracket. Fill system and bleed all air from system and recheck fluid level.

### OVERHAUL

**NOTE** — If complete gearbox assembly is not to be overhauled, remove unit to be overhauled and proceed to disassembly and reassembly of that unit.

#### STEERING GEAR

**Disassembly** — 1) Drain steering gear completely, and mount gear in a soft-jawed vise. Remove lock nut and washer from adjusting screw. Turn input shaft to either stop, then turn shaft back  $1\frac{3}{4}$  turns to center gear. Remove sector shaft cover attaching screws, brake line bracket and identification tag.

Tap lower end of sector shaft with a soft-faced hammer to loosen shaft in bore, then lift shaft and cover assembly from housing. Discard cover "O" ring.

2) Turn sector shaft cover counterclockwise to remove it from adjusting screw. Remove valve housing attaching bolts. Lift valve housing from steering gear housing while holding piston to prevent it from rotating off worm shaft. Remove valve housing and control valve gasket. Discard gasket. Stand valve body and piston assembly on end with piston end downward. Rotate input shaft counterclockwise out of piston, allowing ball bearings to drop into piston. Place a cloth over piston, invert, and remove ball bearings.

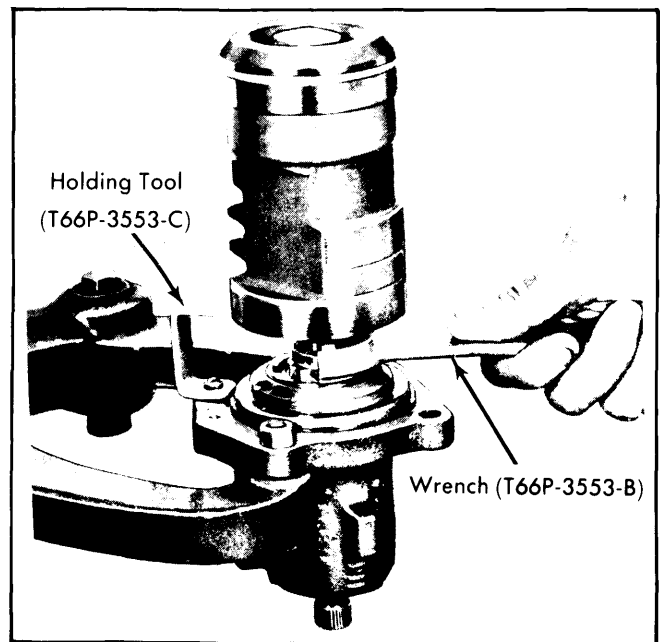

Fig. 2 Removing Worm Bearing Race Nut

3) Remove ball guide clamp attaching screws, then remove clamp and guides. Install valve body in suitable holding fixture, loosen Allen head race nut screw, and remove worm bearing race nut. Carefully slide input shaft, worm, and valve assembly out of valve housing. **CAUTION** — Due to close clearance, cocking of spool may cause it to jam in housing.

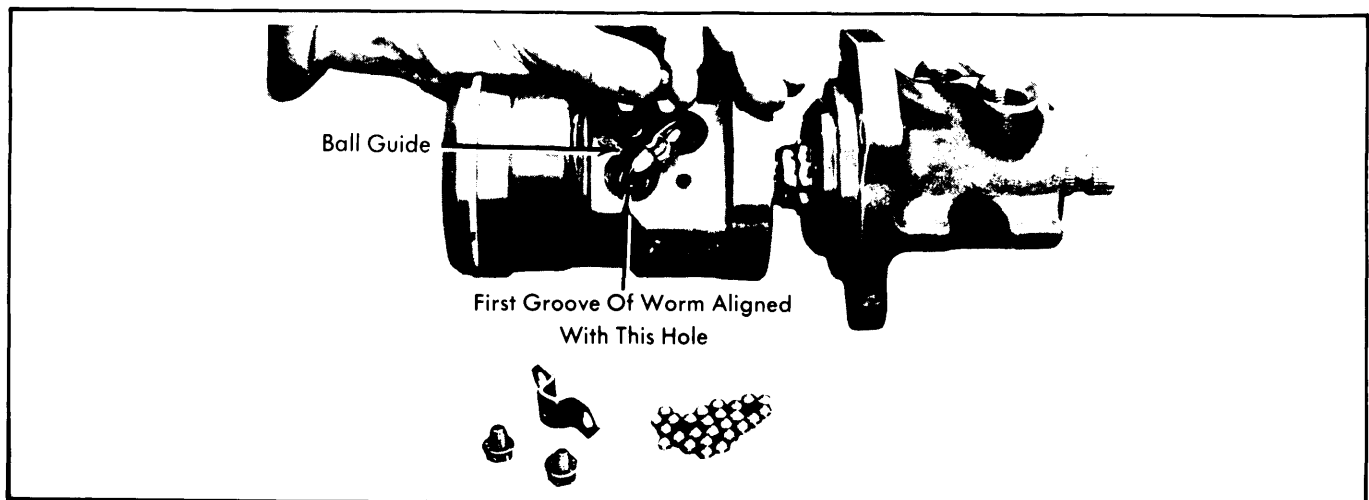

Fig. 3 Installing Piston on Worm Shaft

## FORD MOTOR CO. TORSION BAR (Cont.)

**Reassembly** — 1) Mount valve housing in a suitable holding fixture with flanged end upward. Apply a light coat of lubricant to Teflon rings on valve sleeve, then carefully install worm and valve in housing. Install race nut in housing and tighten securely. Install Allen head race nut set screw through housing and tighten.

2) Place piston on bench with ball guide holes facing up. Insert worm shaft so that first groove in shaft is aligned with hole nearest to center of piston. Position ball guide in piston. Place ball bearings into ball guide, while turning worm in clockwise direction. If all balls have not been fed into guide upon reaching right stop, rotate input shaft back and forth while installing remaining balls. After balls have been installed, DO NOT rotate input shaft or piston more than 3½ turns off right stop. This will prevent balls from falling out of circuit.

3) Secure guides in ball nut with guide clamp. Apply vaseline to Teflon seal on piston, and place a new gasket on valve housing. Slide piston and valve into gear housing, using care not to damage Teflon seal. Align lube passage in valve housing with passage in gear housing. Loosely install housing attaching bolts, rotate ball nut until teeth are in same plane as sector shaft teeth, then tighten valve housing attaching bolts.

4) Position sector shaft cover "O" ring in steering gear housing. Turn input shaft as required to center piston. Apply vaseline to sector shaft journal, position sector shaft and cover assembly in gear housing, and install and tighten cover attaching bolts. Adjust steering overcenter position. See *Overcenter Position Adjustment*.

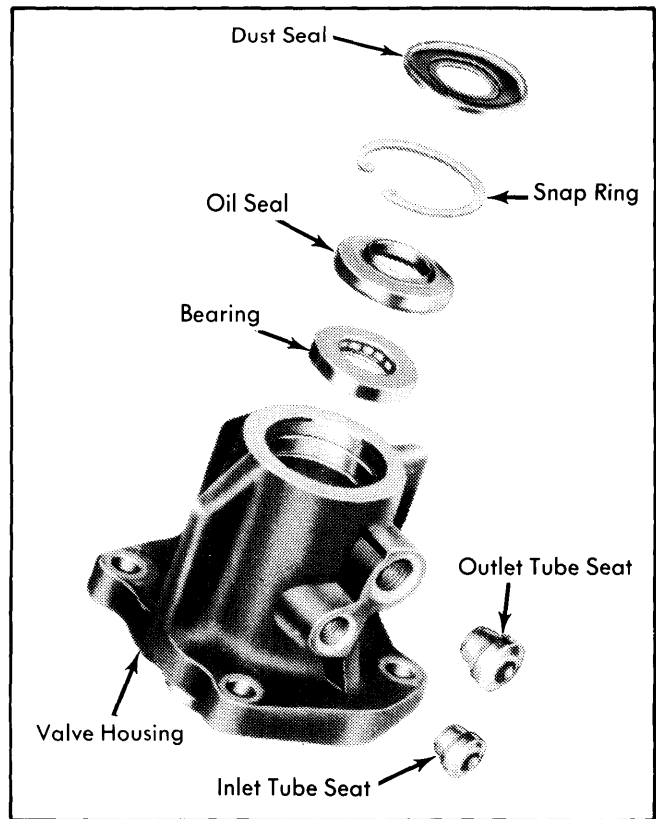

Fig. 4 Disassembled View of Control Valve Housing

### STEERING GEAR HOUSING

**Disassembly & Reassembly** — Remove snap ring and spacer washer from lower end of housing. Using a suitable puller, remove lower seal, spacer washer, and upper seal from housing. Lubricate seals and sector shaft bore with power steering fluid, and position sector shaft seal in housing with lip of seal facing inward. Press seal into place. Place a .090" spacer washer on top of seal, and press outer seal into place with lip facing inward. Place .090" spacer washer on top of outer seal, and install snap ring in groove.

### CONTROL VALVE HOUSING

**Disassembly & Reassembly** — Remove dust seal and snap ring, and discard seal. Invert housing, and drive out bearing and seal, using care not to damage valve bore. Using an E-Z out, remove inlet and outlet tube seats (if necessary). Position new seats in ports, and install hydraulic line nuts to press seats into position. Coat bearing and seal surface of housing with vaseline, then press bearing into position in housing. Dip new oil seal in power steering fluid and place seal in housing with metal side out. Drive seal into housing until outer edge of seal

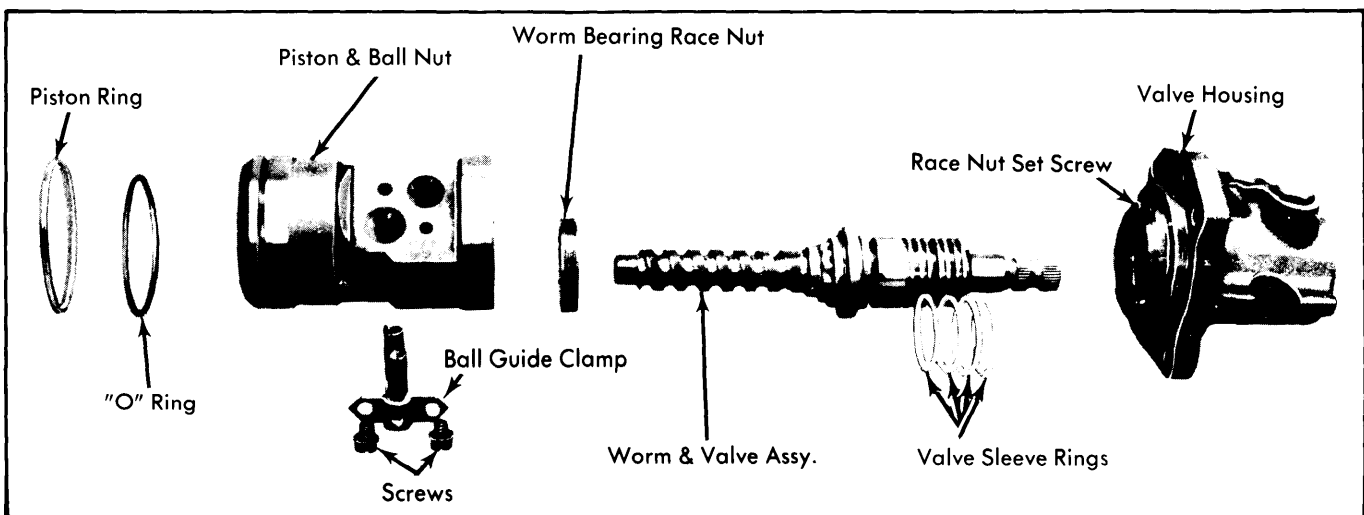

Fig. 5 Disassembled View of Control Valve Assembly

# Power Steering Gears

## FORD MOTOR CO. TORSION BAR (Cont.)

does not quite clear snap ring groove. Position snap ring in housing, and drive on ring until ring seats in groove. This will properly seat seal. Place dust seal in housing with dished side facing out.

### WORM & VALVE SLEEVE

**Disassembly & Reassembly** – Remove rings from sleeve with a small knife. Mount worm end of worm and valve sleeve assembly in a soft-jawed vise and install a suitable mandrel tool (T75L-3517-A1) over the sleeve. Install rings one at a time with the aid of a suitable driver tool (T75L-3517-A2). Rapidly push down on pusher tool to force ring down ramp and into fourth groove of valve sleeve. Repeat three more times, each time adding spacers (Tool T75L-3517-A3) under mandrel tool to line up next groove. After all sleeve rings are installed, install sizing tool (T75L-3517-A4) carefully over valve sleeve rings. Be sure rings are not bent over as tube is slid over them. Remove sizing tool and check condition of rings. They must turn freely.

### PISTON & BALL NUT

**Disassembly & Reassembly** – Remove Teflon ring and "O" ring from piston and ball nut assembly. Dip new "O" ring

in power steering fluid and install it on piston and ball nut. Install new Teflon ring on piston and ball nut, using care not to stretch ring more than necessary.

### TIGHTENING SPECIFICATIONS

Application	Inch Lbs.
Ball Return Guide Clamp Screw .....	42-70
Allen Head Race Nut Setscrew .....	15-25

Application	Ft. Lbs.
Sector Shaft Cover Bolts .....	55-70
Sector Shaft Adjusting Screw Lock Nut .....	35-45
Valve Housing-to-Gear Housing Bolts .....	35-50
Piston End Cap .....	70-110
Race Retaining Nut .....	①

- ① – Tool used with torque wrench will affect observed reading of torque wrench. To obtain required torque wrench reading, multiply length of torque wrench by desired torque (60 ft. lbs.), and divide this product by sum of torque wrench length plus length of tool (5.5").