

GENERAL MOTORS (Cont.)

"K" MODELS

Steering Connecting Rod — 1) Remove cotter pins from ball studs and remove castellated nuts. Remove ball studs from steering arm and pitman arm boss with a heavy hammer and striking other side of boss with a lighter hammer.

2) To install, reverse removal procedure and note following: Ensure that threads on studs and nuts are clean and smooth. Check ball stud seals and replace if necessary. Install connecting rod on steering components, torque nuts and install new cotter pins. See illustration for proper alignment and orientation of connecting rod clamps.

TIGHTENING SPECIFICATIONS

Application	Ft. Lbs.	Application	Ft. Lbs.
Tie Rod Ball Stud Nuts	①45	Pitman Arm-to-Pitman Shaft Nut	
Tie Rod Clamps	22	K10-20	90
Idle Arm Mounting Bolt	30	"P" Motor Home Chassis	125
Idle Arm-to-Relay Rod Nut		All Other Models	185
G10-30	70	Pitman Arm-to-Idle Support Arm Nut	
All Other Models	60	P10-30 & "P" Motor Home Chassis	125
Pitman Arm-to-Relay Rod Nut		Relay Support Assembly-to-Frame Nut	
G10-30	70	P10-30 & "P" Motor Home Chassis	48
All Other Models	60		
Steering Connecting Rod Nut		① — Plus torque required to align cotter pin with maximum torque of 60 ft. lbs.	
P10-30 & "P" Motor Home Chassis	②70	② — Plus torque required to align cotter pin with maximum torque of 100 ft. lbs.	
K10-20	③50	③ — Plus next slot for cotter pin.	
Steering Connecting Rod Clamps			
K10-20	40		

INTERNATIONAL HARVESTER

ALL MODELS

Tie Rod Removal — Remove cotter pins from ball studs at each end of tie rod. Remove nuts. Separate tie rod end ball studs from steering arms. To install, reverse removal procedure. Install new cotter pins.

Tie Rod End Replacement — Loosen tie rod end clamp bolts. Unscrew tie rod end from tie rod. To install, reverse removal procedure. Make sure tie rod end is threaded into tie rod sufficiently so that clamping action will be directly over threads. Position clamp on tie rod as shown in illustration (see Fig. 2).

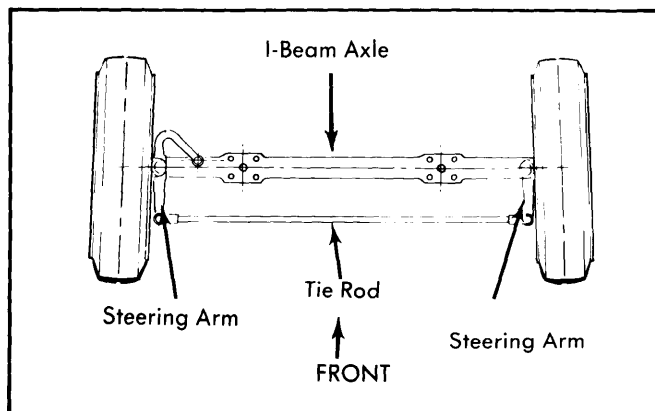

Fig. 1 Steering Linkage for MS and MHC Models

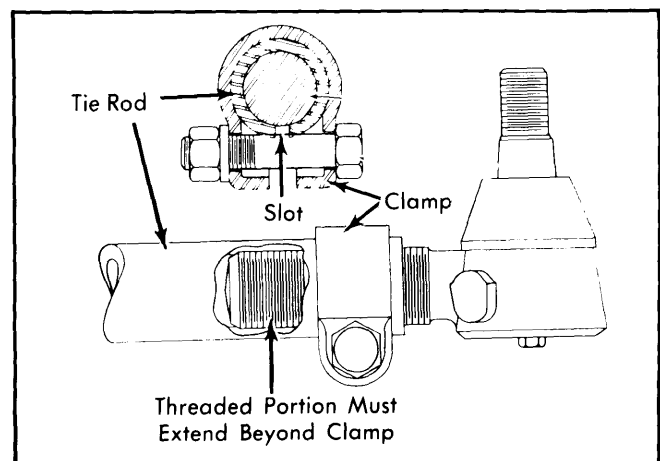

Fig. 2 Positioning Clamps on Tie Rod