

JEEP

Cherokee
"CJ" Models
"J" Models
Wagoneer

DESCRIPTION

All models use a collapsible column which is equipped with an anti-theft locking feature. All models are available with an optional Adjust-O-Tilt steering column. The Adjust-O-Tilt steering column is also equipped with the energy-absorbing and anti-theft features.

REMOVAL & INSTALLATION

CAUTION — When servicing the steering column, use ONLY specified attaching screws and bolts. Screws or bolts longer than specified could damage collapsible feature of the steering column. Attaching nuts and bolts for the column mounting bracket must be tightened to specifications to allow bracket to break away under impact.

ALL MODELS

Removal — 1) Disconnect battery ground cable. If equipped with automatic transmission, disconnect transmission shift rod at steering column shift lever.

2) On Cherokee, Wagoneer and Truck models, it will be necessary to shift transmission to "1" detent position to gain access to shift rod retaining clip at shift lever.

3) Remove upper steering shaft to intermediate shaft "U" joint pinch bolt. Do not attempt to separate upper steering shaft and intermediate shaft at this time.

4) On Cherokee, Wagoneer and Truck models with air conditioning, remove left duct extension. Remove steering column to instrument panel bezel. On Cherokee and Wagoneer models, bezel screws are located behind lower bezel.

5) Remove bolts securing steering column mounting bracket to instrument panel. Remove bolts securing mounting bracket to steering column and remove bracket.

CAUTION — It is recommended that the bracket be stored in a safe place to prevent damage to breakaway capsules.

6) Remove upper and lower toe-plates. On vehicles with automatic transmission, disconnect wiring terminal at neutral safety switch. Disconnect electrical connectors at ignition switch, disconnecting black connector first. Disconnect directional signal switch connector.

7) If equipped with Cruise Command, disconnect electrical connector. Separate steering shaft from intermediate "U" joint and remove steering column assembly.

CAUTION — It is recommended that steering column be handled with care after removal. Blows on end of steering shaft or shift levers, leaning on column assembly, or dropping unit may cause damage to energy absorbing components.

Installation — 1) Place steering column in vehicle. Connect upper steering shaft to intermediate shaft "U" joint. Install "U" joint pinch bolt and tighten to specification.

2) If equipped with Cruise Command, connect electrical connector. Connect ignition switch connectors. Connect white connector first. Connect neutral safety switch connector if equipped with automatic transmission. Connect directional signal switch connector.

3) Install upper and lower toe plates. Install bolts but do not tighten. Install mounting bracket on steering column. Align column with instrument panel. Install bracket to instrument panel bolts but do not tighten.

4) Pull up on column and tighten bolts to specification. Make sure bolts are tightened while pulling up on column. Tighten toe plate bolts to specification.

5) Install both halves of instrument panel bezel. Install left air conditioning duct extension (if removed). Connect transmission shift rod to shift lever.

6) Connect battery ground cable. Check automatic transmission shift linkage operation and adjust as necessary. Check for correct operation of all electrical components.

OVERHAUL

ALL MODELS
WITHOUT TILT WHEEL

Disassembly (Man. Trans.) — 1) Remove steering column from vehicle as previously outlined. Remove mount bracket from column. Attach a suitable holding fixture (J-23074) to mount bolt holes. Secure column in a vise by clamping on holding fixture.

2) Remove steering wheel. Using two screwdrivers, pry anti-theft cover off lock plate. Compress lock plate using a suitable compressor tool (J-23653) (see Fig. 1). Remove snap ring from steering shaft.

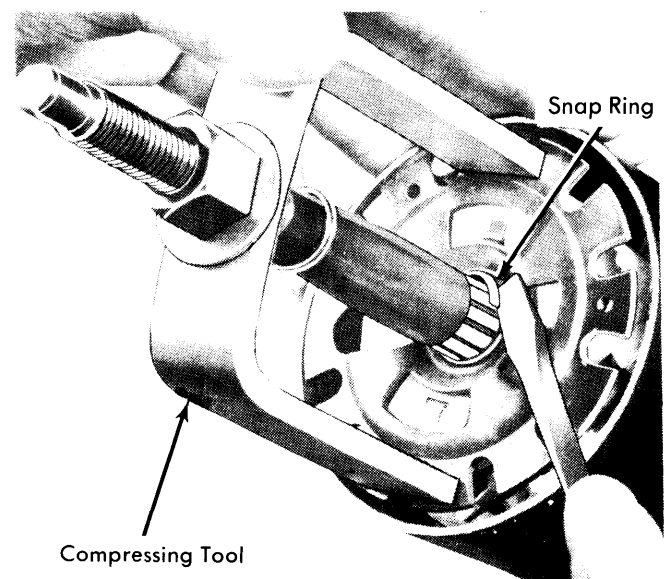

Fig. 1 Removing Lock Plate Snap Ring

3) Remove compressor tool. Remove snap ring and discard. Remove lock plate, directional signal cancelling cam, upper bearing preload spring, and thrust washer from steering shaft.

JEEP (Cont.)

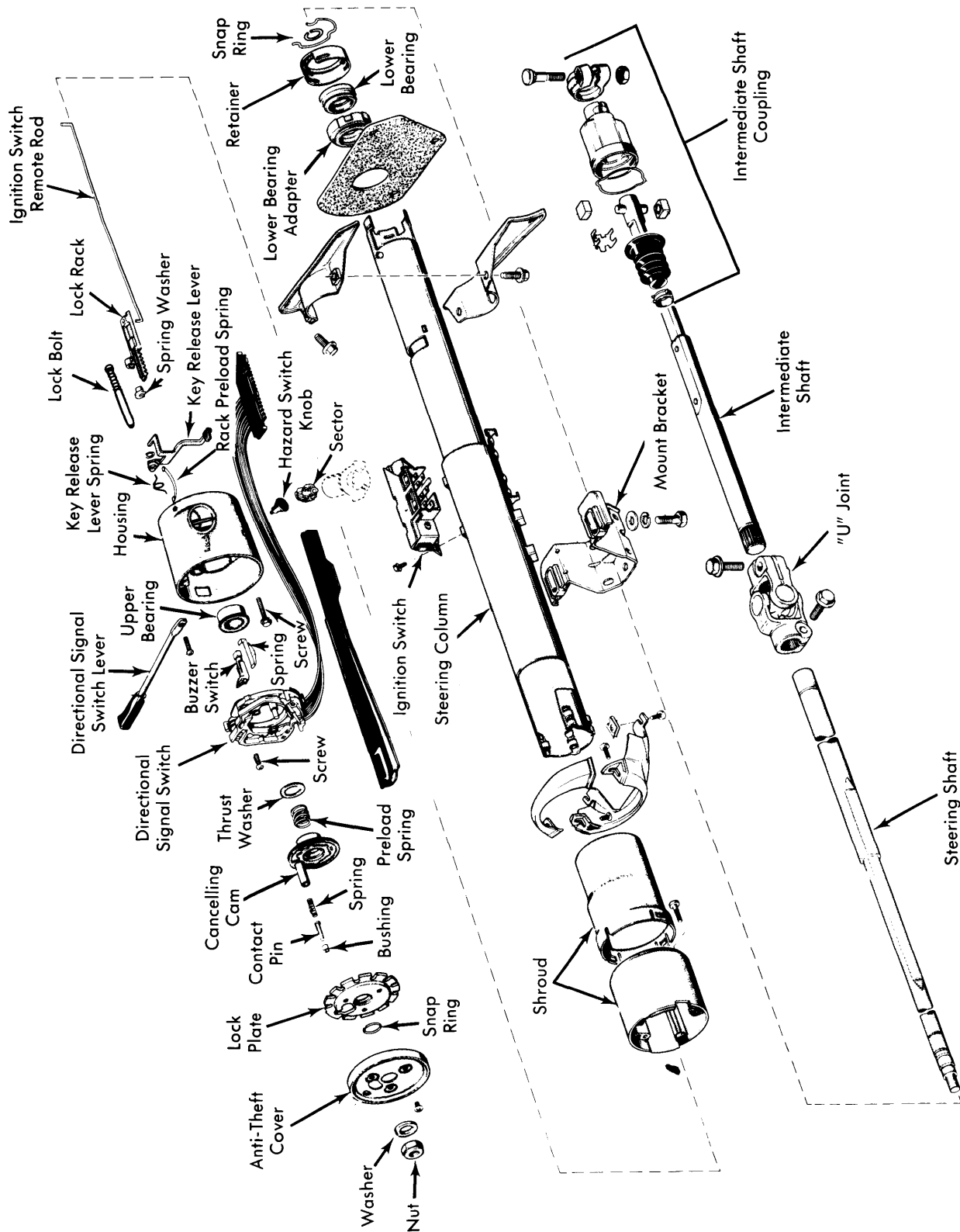

Fig. 2 Exploded View of Steering Column (Manual Transmission Models)

Steering Columns

JEEP (Cont.)

CAUTION — After snap ring is removed from shaft, the steering shaft is free in column. Do not allow shaft to fall out end of column.

4) Remove steering shaft from lower end of column. Remove hazard warning switch knob by pressing inward and unscrewing. On vehicles without Cruise Command, remove directional signal switch lever.

5) On vehicles with Cruise Command, disconnect two of four wires at switch connector. Fold wires back along harness. Tape wires and a length of string to harness to aid removal.

6) Remove directional signal switch connector from bracket at lower end of column. Separate switch connector. Wrap tape around connector and harness to prevent snagging during removal.

7) Remove directional signal switch screws. Remove switch and harness by pulling straight up and out of column. On vehicles with Cruise Command, remove directional switch lever. Remove Cruise Command switch (in directional signal switch lever) and harness using string taped to harness.

8) Turn ignition lock cylinder to "RUN" position. Using a thin bladed screwdriver, compress lock cylinder retaining tab and remove cylinder from column. The retaining tab is reached through slot next to directional signal switch mounting boss.

NOTE — If retaining tab is not visible through slot, remove any casting flash that may be in slot.

9) Remove ignition switch from lower end of column. Remove screws securing directional signal switch housing and shroud to column. Remove housing and shroud. Disconnect ignition switch remote rod from lock rack.

10) Remove screws securing shroud to housing and remove shroud. Remove wave washer from key-release lever pivot. Remove key release lever and spring. Remove lock rack and bolt assembly. Remove rack preload spring.

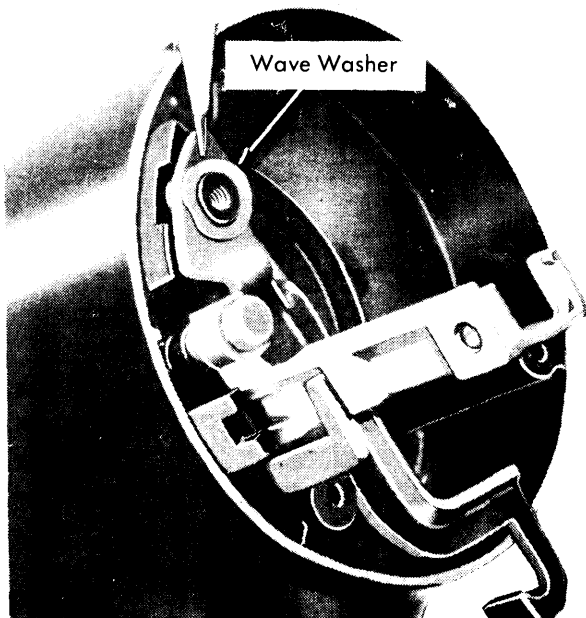

Fig. 3 Wave Washer Removal on Manual Transmission Models

11) Using a punch, push on block tooth of sector and push sector through lock cylinder hole. Remove lower bearing snap ring from retainer. Remove retainer, bearing and adapter.

Reassembly — 1) Coat all friction surfaces with multi-purpose grease before reassembly. Position sector on sector shaft. Insert sector through lock cylinder hole. Use a blunt punch to push sector into place. Make sure sector turns freely after installation.

2) Install rack preload spring. Make sure bowed side of preload spring is against lock rack. Assemble lock rack and lock bolt as shown in illustration (see Fig. 4).

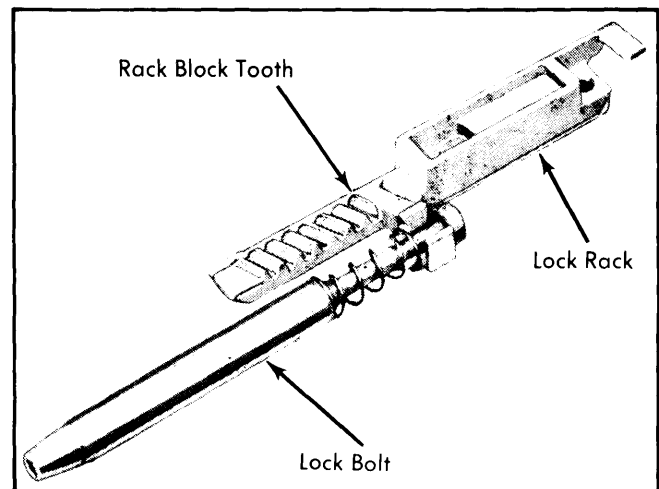

Fig. 4 Assembly Lock Bolt and Lock Rack

3) Install assembled lock bolt and lock rack in housing. Make sure block tooth of lock rack is mated with block tooth of sector as shown in illustration (see Fig. 5).

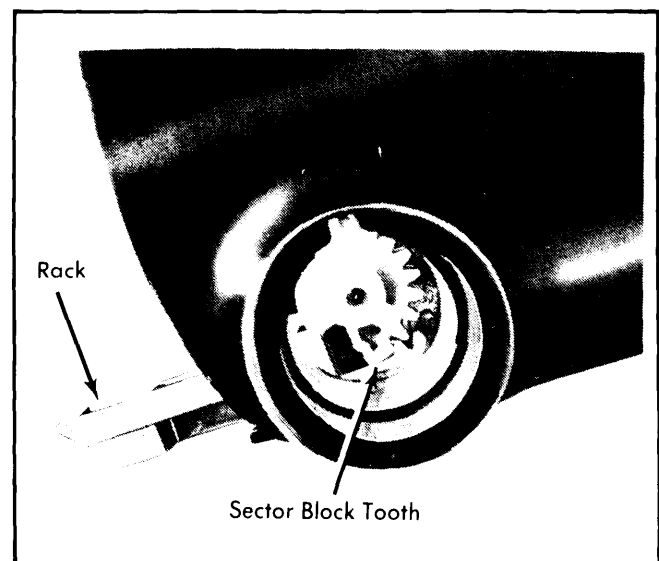

Fig. 5 Installing Lock Bolt and Lock Rack

4) Place key release lever return spring over post in housing. Place release lever finger in lock rack slot. Position hole in lever over threaded hole in housing post. Make sure inner end of spring contacts release lever.

JEEP (Cont.)

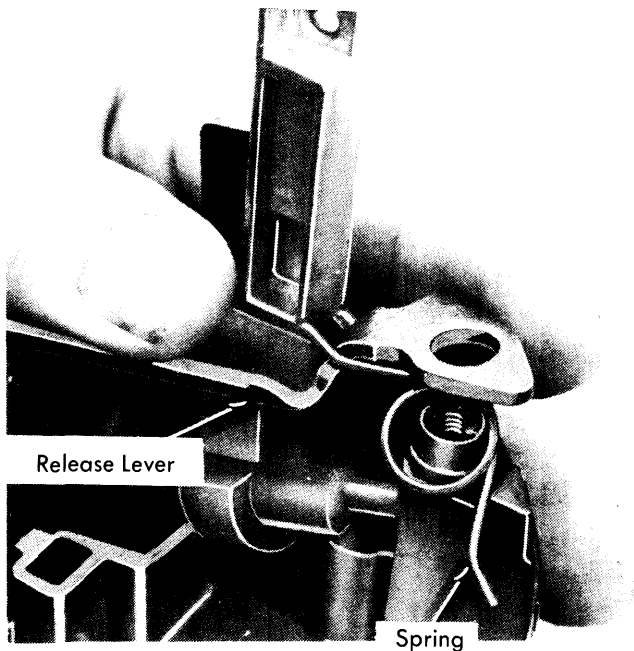

Fig. 6 Installing Release Lever and Spring on Manual Transmission Models

5) Raise lever slightly and place end of lever spring between lever and housing boss. Coat wave washer with multi-purpose grease. Place wave washer on post over release lever.

6) Place shroud on directional signal switch housing. Install and tighten retaining screws. Make sure release lever wave washer is not dislodged when shroud is installed. Install remote rod on lock rack with short end of rod in rack.

7) Place assembled housing and shroud on column. Install and tighten retaining screws to specification. Insert key in lock cylinder. Hold cylinder sleeve and rotate key clockwise until key stops. This will retract actuator.

8) Place lock cylinder in housing bore making sure cylinder tab is aligned with keyway in housing. Push cylinder inward until it bottoms. Rotate key counterclockwise until drive section of cylinder mates with sector. Push cylinder in fully until tab engages in housing groove.

9) Now turn cylinder clockwise to stop, then counterclockwise to stop at "OFF-UNLOCK" position. Place ignition switch on jacket. Move switch to extreme left position ("ACC"). Now move slider two positions to right ("OFF-Unlock"). Insert remote rod into switch slider hole. Place switch on column. Install and tighten retaining screws.

10) Install lower bearing, bearing adapter, retainer and snap ring in lower end of column. Insert steering shaft in column through lower end. Bend directional signal switch wires against connector. Feed connector and harness through housing and shroud. Align switch in housing. Install and tighten retaining screws.

11) On vehicles without Cruise Command, install directional signal switch lever. On vehicles with Cruise Command, install lever and switch assembly. Use string taped to harness during disassembly to help feed wires into housing. Remove string and tape. Connect wires to switch terminal and install lever.

12) Install thrust washer, upper bearing preload spring, and cancelling cam on steering shaft. Position cancelling cam as shown in illustration (see Fig. 7). Place directional signal switch in neutral position and install hazard warning switch knob.

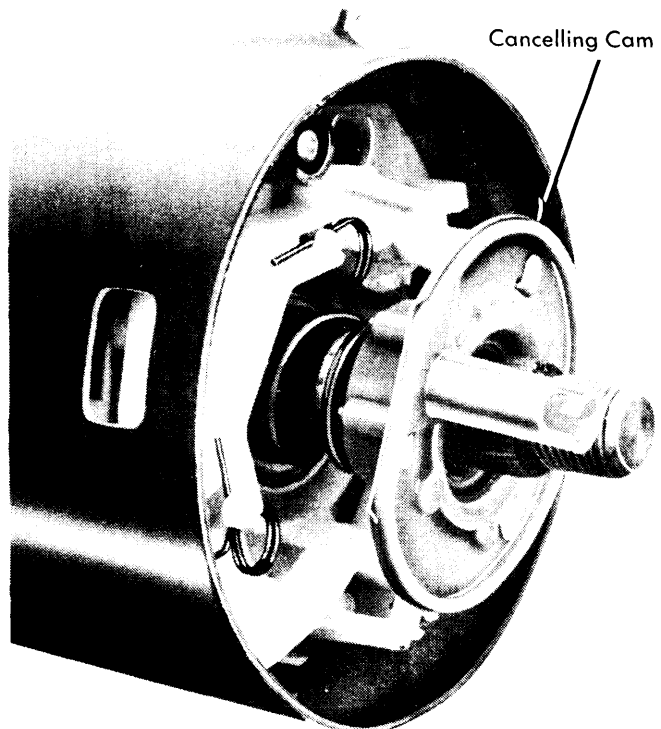

Fig. 7 Directional Signal Switch Cancelling Cam Position

13) Place new snap ring on sleeve of compressor tool (J-23653). Thread tool sleeve onto end of steering shaft. Compress lock plate with tool and install snap ring in groove in steering shaft. Install anti-theft cover.

14) Remove support tool from steering column. Install mounting bracket and tighten bolts to specification. Connect directional signal switch wire connector to column bracket. Install steering wheel. Install column in vehicle as previously outlined.

Disassembly (Auto. Trans.) – 1) Remove steering column from vehicle as previously outlined. Remove mount bracket from column. Attach a suitable holding fixture (J-23074) to mount bolt holes. Secure column in a vise by clamping holding fixture.

2) Remove steering wheel. Using two screwdrivers, pry anti-theft cover off lock plate. Compress lock plate using a suitable compressor tool (J-23653) (see Fig. 7). Remove snap ring from steering shaft.

3) Remove compressor tool. Remove snap ring and discard. Remove lock plate, directional signal cancelling cam, upper bearing preload spring, and thrust washer from steering shaft.

CAUTION – After snap ring is removed from steering shaft, shaft is free in column. Do not allow shaft to fall out end of column.

Steering Columns

JEEP (Cont.)

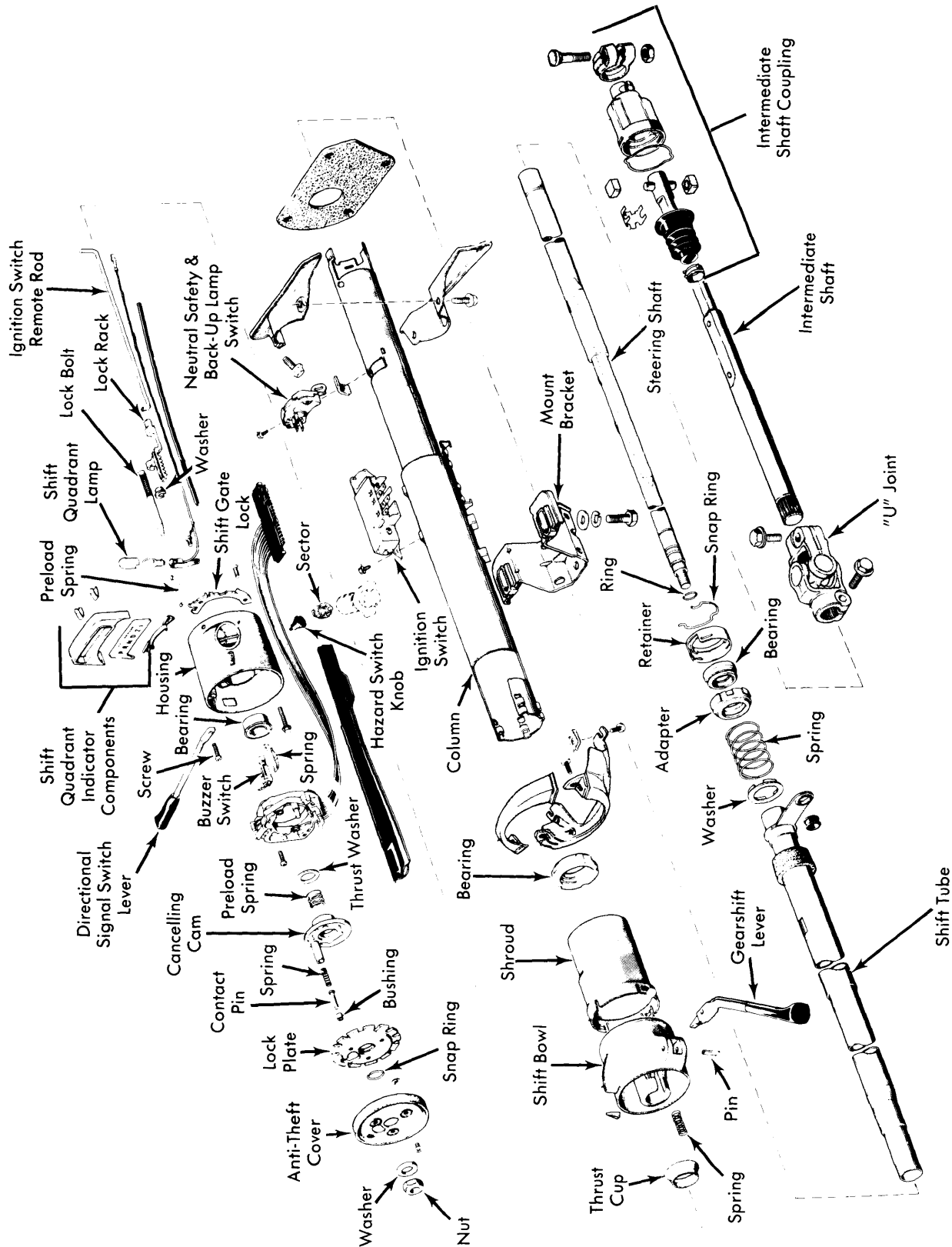

Fig. 8 Exploded View of Steering Column (Automatic Transmission Models)

JEEP (Cont.)

4) Remove steering shaft from lower end of column. Remove hazard warning switch knob by pressing inward and unscrewing. On vehicles without Cruise Command, remove directional signal switch lever.

5) On vehicles with Cruise Command, disconnect two of four wires at switch connector. Fold wires back along harness. Tape wires and a length of string to harness to aid removal.

6) Place gearshift lever in "P". Drive out gearshift lever pin using a small drift punch. Remove gearshift lever. Disconnect directional signal switch connector from bracket at lower end of column.

7) Remove lower bracket and plastic wiring harness protector. Wrap tape around directional signal switch connector and wiring harness to prevent snagging during switch removal.

8) Pull switch straight up and out of column to remove. On vehicles with Cruise Command, remove directional signal switch lever. Remove Cruise Command switch (in directional signal switch lever) and harness using string taped to harness.

9) Place lock cylinder in "LOCK" position. Compress cylinder retaining tab and remove lock cylinder. The retaining tab is reached through slot next to directional signal boss in housing.

NOTE— If retaining tab is not visible through slot, remove any casting flash that may be in slot.

10) Remove ignition switch from lower end of column. Remove screws securing upper housing to column and remove housing. The ignition switch remote rod and shift quadrant light wire will be removed with upper housing.

11) Remove thrust cup from upper housing. Remove lock bolt and rack. Remove rack and preload spring. Using a blunt punch, remove sector from sector shaft. Note position of sector for reassembly. Remove sector through lock cylinder hole.

12) Remove shift gate lock from upper housing. Inspect shift gate lock detents for wear and replace as necessary. Remove shift quadrant by prying out two clips with a small punch. Remove quadrant light cover and socket assembly.

13) Remove shift bowl from column. Remove lower nylon bowl bearing from upper end of column. Remove lower bearing retainer, retaining ring, preload spring and nylon washer. Remove neutral safety and back-up lamp switch. Remove shift tube and nylon bearing from tube.

Assembly (Auto. Trans.) — 1) Apply multi-purpose grease to all friction surfaces. Install shift tube. Install nylon thrust washer in lower end of shift tube making sure flat side of washer faces upper end of tube.

2) Install preload spring and lower bearing making sure bearing metal face is toward retainer. Install retainer and retainer ring. Install neutral safety and back-up lamp switch.

3) Install lower nylon bearing in upper end of column. Make sure smaller inside diameter faces toward lower end of tube and bearing notches engage three locator crimps in column.

4) Align shift bowl with shift tube spline and install bowl. Install rack preload spring in upper housing. Place large end of sector on sector shaft. Place sector into place using a blunt punch.

5) Install shift gate lock and retaining screws. Tighten screws to specification. Install shift quadrant lamp and cover. Install quadrant indicator by pressing retainer clips into place with flat side toward bowl.

6) Assemble lock bolt and lock rack (see Fig. 4). Install lock bolt and lock rack in column (see Fig. 9). Make sure block tooth of lock rack engages block tooth of sector (see Fig. 5).

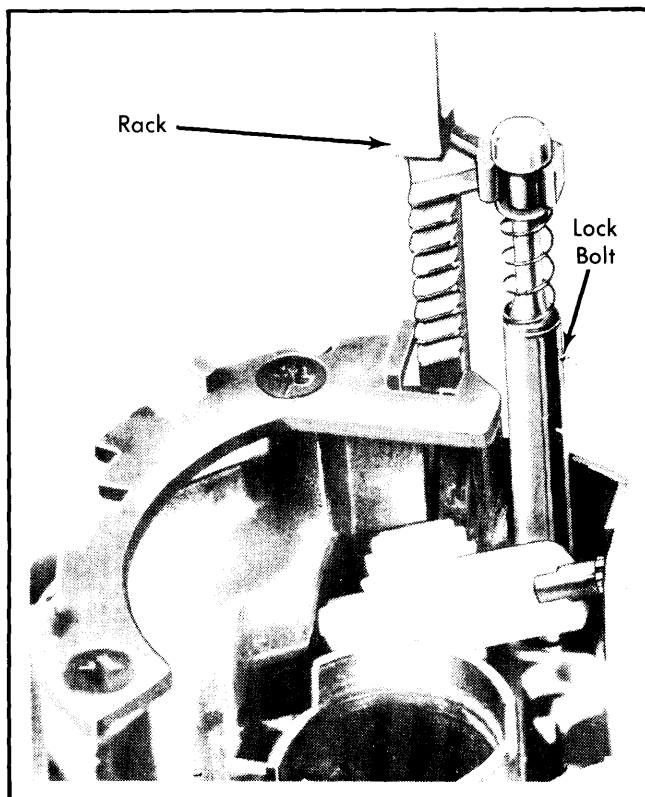

Fig. 9 Installing Lock Rack and Bolt into Shift Bowl

7) Install nylon thrust cup in upper housing, making sure flared end of cup faces outward. Rotate shift bowl as far as possible counterclockwise and install upper housing. Tighten screws to specification.

8) Guide shift quadrant lamp wire and remote lock rod into position between shift bowl and column. Install directional signal switch and harness in column. Remove tape from harness and connector. Place harness in plastic protector. Install and tighten switch retaining screws.

NOTE — Make sure switch actuating lever pivot is correctly aligned and seated in upper housing boss.

9) On vehicles without Cruise Command, install directional signal switch lever. On vehicles with Cruise Command, install directional signal switch lever and Cruise Command switch using string taped to harness. Remove string and tape. Connect wires to terminals.

10) Install steering shaft from lower end of column. Install thrust washer, upper bearing preload spring and cancelling cam on steering shaft. Install lock plate, making sure lock plate splines are aligned with steering shaft splines. Make sure cancelling cam shaft protrudes through lock plate opening.

JEEP (Cont.)

11) Install a new steering shaft snap ring on lock plate depressor tool (J-23653). Thread tool onto steering shaft. Compress lock plate with tool. Install snap ring in groove in steering shaft. Remove compressor tool.

12) Install anti-theft cover. Install steering wheel. Install gearshift lever. Install lock cylinder in cover. Install ignition switch on column. Place shift bowl in any position but "P". Rotate bowl until lock rack bottoms against lower surface of bowl.

13) Move ignition switch slider to left toward "ACC" position. Move slide two positions to right toward "OFF-UNLOCK" position. Insert remote rod into slider hole. Move switch out of "OFF-UNLOCK" position.

14) Install column in vehicle as previously outlined. Adjust neutral safety and back-up light switch.

ALL MODELS WITH TILT WHEEL

Disassembly - 1) Remove steering column from vehicle as previously outlined. Remove mount bracket from column. Attach a suitable holding fixture (J-23074) to mount bolt holes. Secure column in a vise by clamping on holding fixture.

2) Remove steering wheel. Using two screwdrivers, pry anti-theft cover off lock plate. Compress lock plate using a suitable compressor tool (J-23653) (see Fig. 1). Remove snap ring from groove in steering shaft.

3) Remove compressor tool. Remove snap ring and discard. Remove lock plate, directional signal cancelling cam, upper bearing preload spring, and thrust washer from steering shaft. Remove gearshift lever retaining pin and remove gearshift lever.

4) On vehicles without Cruise Command, remove directional signal switch lever. On vehicles with Cruise Command, remove wires from Cruise Command switch terminal. Fold two of four wires back and tape along harness. Tape a length of string to harness to aid removal.

5) Remove hazard warning switch knob by pressing in and unscrewing. Disconnect directional signal switch connector at bracket on lower steering column. Remove wiring harness plastic connector from column jacket.

6) Wrap tape around directional signal switch connector to prevent snagging when removing. Remove directional signal switch retaining screws. Pull switch and harness straight up out of column.

7) On vehicles with Cruise Command, remove directional signal switch lever. Remove Cruise Command switch (in directional signal switch lever) and harness using string taped to harness.

8) Insert ignition key in lock cylinder. Turn key to "LOCK" position. Compress cylinder retaining tab and remove lock cylinder. The retaining tab is reached through slot next to directional signal switch boss in housing.

NOTE - If retaining tab is not visible through slot, remove any casting flash that may be in slot.

9) Remove shift quadrant by prying two spring clips out of column. Remove mounting bracket and light socket. Remove

tilt release handle. Remove cover retaining screws and remove cover.

10) Remove lock sector tension spring screw. Unhook sector spring from sector shaft. Remove snap ring from sector shaft. Remove sector, shaft and lockpin. Install tilt release handle. Place column in full upward tilt position.

11) Insert a screwdriver in tilt release spring retainer slot and compress retainer approximately $\frac{3}{16}$ ". Rotate retainer $\frac{1}{8}$ turn and remove retainer and spring.

CAUTION - Tilt spring is under strong tension.

12) Place housing in center position. Using suitable puller (J-21854-1) remove tilt pivot pins (see Fig. 10). Lift tilt release lever to disengage lock shoes and remove housing. Remove both ball bearing assemblies from housing (if necessary).

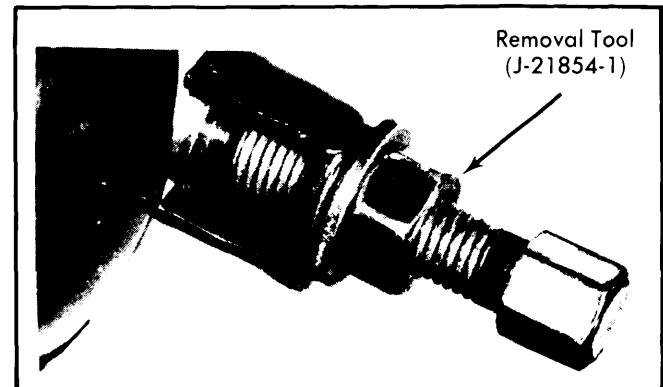

Fig. 10 Removing Tilt Pivot Pins

13) Remove tilt release lever. Using a punch, drive out release lever pin. Compress lock shoe spring to release spring tension on pin (see Fig. 11).

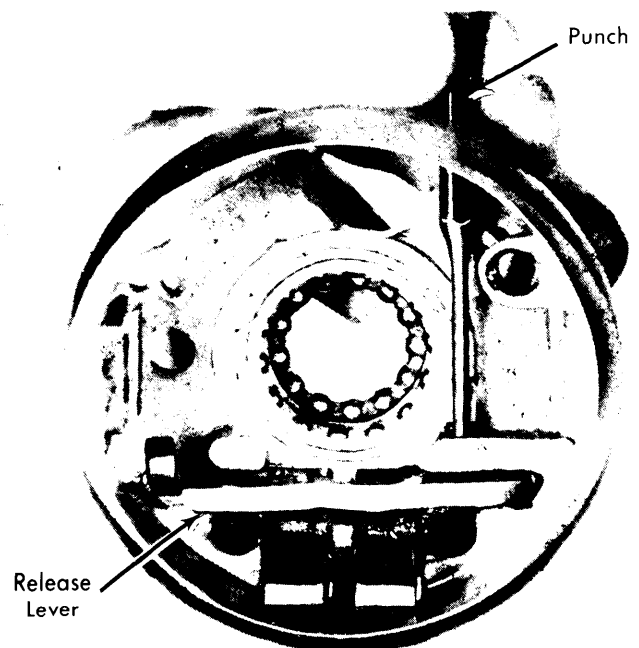

Fig. 11 Removing Release Lever Pin

JEEP (Cont.)

14) Using a punch, drive out lock shoe pin (see Fig. 12). Compress lock shoe spring to release spring tension on pin. Disconnect steering shaft. Remove shaft through upper end of column.

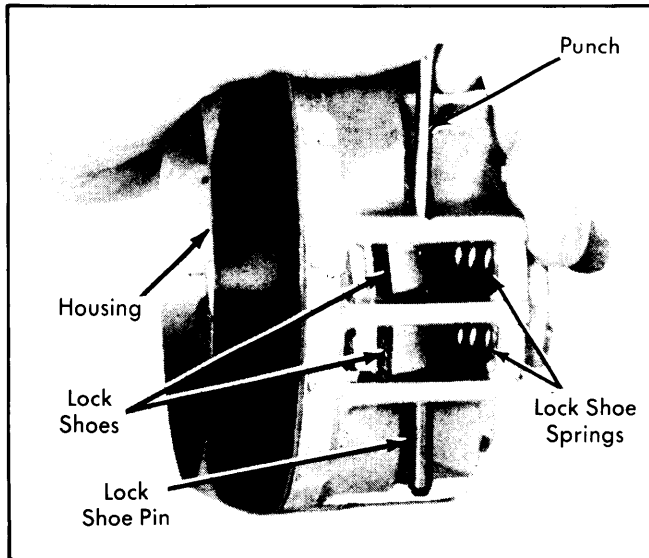

Fig. 12 Removing Lock Shoe Pin

15) Fold shaft at 90° and separate upper and lower halves at flex joint. Remove ignition switch. Remove neutral and backup lamp switch. Remove lock rack and remote rod.

16) Remove screws securing support to shift bowl. Remove shift gate pin and remove shift gate from support. Remove shift tube retaining ring and thrust washer. Using a suitable puller (J-23072), pull shift tube from column.

17) Rotate shift bowl clockwise while sliding retainer plate out of jacket notches. Tip plate down toward shift bowl hub at 12 o'clock position and remove plate, bottom side first.

18) Remove wave washer and shift tube spring. Remove shift bowl from column jacket. Remove lower bearing retainer spring clip. Remove retainer, lower bearing and bearing adapter.

Reassembly — 1) Coat all friction surfaces with multi-purpose grease before reassembly. Mount shift bowl on column. Place shift tube spring, wave washer, and retainer plate in shift bowl.

2) Install shift tube through lower end of column. Make sure tube spline is aligned with shift bowl keyway. Place shift tube installer tools (J-23073-2 and J-23073-4) in shift bowl. Make sure spring loaded lower foot of tool is engaged with shift tube inner shoulder and tool guide is seated in shift tube (see Fig. 13).

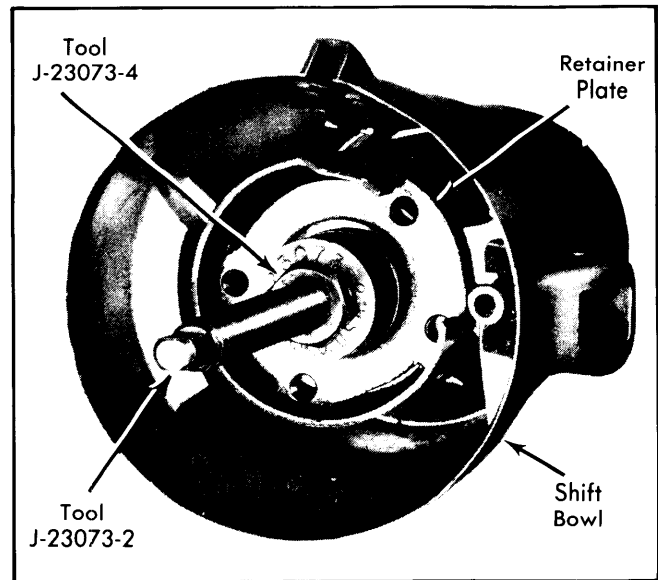

Fig. 13 Positioning Shift Tube Installer Tools

3) Tighten tool spring tension nut until snug. Place installer tools (J-23073-3 and J-23073-4) over puller stud. Tighten tool nut (J-23073-2) and pull tube into place in shift bowl. Remove shift tube installer tools.

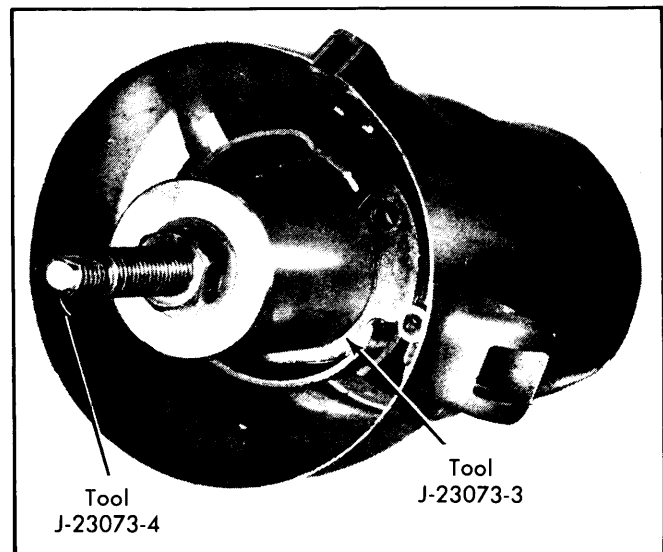

Fig. 14 Pulling Shift Tube into Shift Bowl

4) Install shift tube thrust washer and retainer plate snap ring. Install lower bearing adapter, making sure notched end of adapter faces lower end of column. Install lower bearing in column. Make sure metal face of bearing faces lower end of column.

5) Install pin and shift gate in support. Install support in shift bowl. Make sure "V" notch in support is aligned with notch in column. Install support to shift bowl screws.

Steering Columns

JEEP (Cont.)

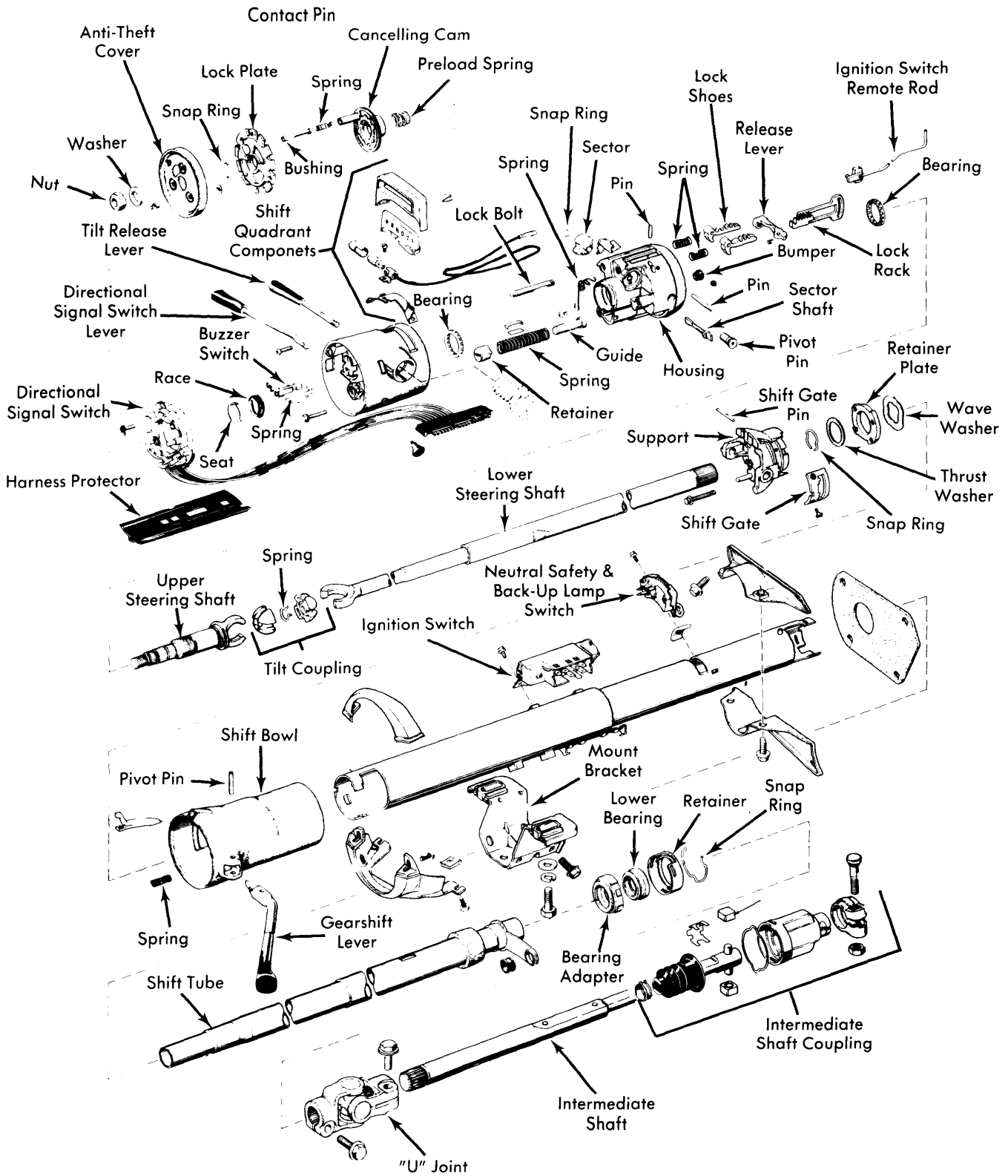

Fig. 15 Exploded View of Adjust-O-Tilt Steering Column

JEEP (Cont.)

6) Assemble upper and lower steering shafts at flexible joint. Install steering shaft through upper end of column. Install ball bearings in housing if removed. Make sure there are 14 balls in each bearing.

7) Install tilt release handle. Insert ignition switch remote rod between shift bowl and column and into guide channel in left side of support. Place lock rack on remote rod. Guide housing over steering shaft and lock rack, making sure lock shoes align with teeth in support.

8) Align housing and drive in pivot pins using a soft faced mallet. Install lock shoes, lock shoe springs, tilt bumpers and lockpin in housing. Install lock sector and sector shaft. Large tooth of sector must engage large slot in lock rack. Install sector shaft snap ring.

9) Hook lock sector tension spring on lockpin. Engage with sector and install spring retaining screw. Place housing in full upward tilt position. Install tilt spring and seat.

10) Push tilt spring retainer into housing $\frac{3}{16}$ " and rotate retainer $\frac{1}{8}$ turn clockwise to secure spring. Place housing in center tilt position. Remove tilt release handle. Install cover on housing and install retaining screws.

11) Insert shift quadrant light wire up through housing and down between shift bowl and column jacket. Install shift quadrant mounting bracket and connect light socket. Hook base of shift quadrant over tabs on left side of retainer and snap in position.

12) Install quadrant pointer in shift bowl and engage in quadrant. Install quadrant retainer clip with flat side of clip facing downward. Install tilt release handle. Place directional signal switch and harness in column. Guide harness between cover and column.

13) On vehicles without Cruise Command, install directional signal lever. On vehicles with Cruise Command, install directional signal lever and Cruise Command switch assembly. Use string taped to connector during disassembly to install connector.

14) Remove tape and string from connector. Connect four wires to switch terminal. Install and tighten lever screw. Place directional signal switch harness in plastic protector. Align directional signal switch in cover. Install and tighten retaining screws.

15) Install bearing race, bearing race seat, preload spring, and cancelling cam on steering shaft. Align lock plate splines with steering shaft splines. Install lock plate. Make sure cancelling cam shaft protrudes through hole in lock plate.

16) Install new steering shaft snap ring on lock plate compressor tool (J-23653) and position tool on steering shaft. Compress lock plate with tool. Install snap ring in groove in steering shaft. Remove tool.

17) Place gearshift lever in shift bowl. Guide gearshift lever over lock sector tension spring and into bowl. Align retaining pin holes with a punch. Drive retaining pin into position using a soft faced hammer.

18) Insert ignition key into lock cylinder. Hold lock cylinder and turn key clockwise to stop. Align cylinder locking lug with keyway in cover and insert cylinder in cover. Push cylinder against lock sector. Rotate cylinder counterclockwise until it engages sector. Push cylinder inward until retainer tab snaps into place.

19) Install steering column as previously outlined. Install steering wheel. Adjust gearshift linkage, and neutral safety and backup lamp switch.

TIGHTENING SPECIFICATIONS

Application	Ft. Lbs.
Intermediate Shaft-to-"U" JointBolt	30
Mount Bracket-to-Column	15
Mount Bracket-to-Instrument Panel	20
Toe Plate Screws	15
Steering Wheel Nut	
Man. Trans.	30
Auto. Trans.	20

Application	INCH Lbs.
Manual Transmission Columns	
Shroud-to-Housing	18
Directional Signal Switch Screws	35
Directional Signal Switch Lever Screw	35
Ignition Switch Screws	35
Automatic Transmission Columns	
Shift Gate Screws	45
Upper Housing Screws	60
Directional Signal Switch Screws	35
Directional Signal Switch Lever Screw	35
Ignition Switch Screw	35
Adjust-O-Tilt Columns	
Directional Signal Switch Screws	35
Directional Signal Switch Lever Screw	35