

INTERNATIONAL HARVESTER

Scout II, Terra & Traveler

REMOVAL & INSTALLATION

NOTE — Disconnect battery before servicing any electrical components.

NOTE — Scribe mark on steering wheel and shaft to aid reassembly.

HORN BUTTON & STEERING WHEEL

Scout II, Terra & Traveler — Rotate horn button counterclockwise and remove. Disconnect horn wire. Remove retaining screws and horn contact ring. Remove nut and washer securing steering wheel to shaft, and using a wheel puller (SE-1821), remove steering wheel. To install, reverse removal procedures.

DIRECTIONAL SIGNAL SWITCH

Scout II, Terra & Traveler — 1) Remove horn button and steering wheel. Remove horn contact spring. Depress lock plate by installing a suitable tool and tightening down with steering wheel retainer nut. Remove lock plate snap ring with a screwdriver. Remove depressor tool, snap ring, and lock plate from column. **NOTE** — If steering column is removed from vehicle, shaft can slide out of column when retaining ring is removed.

2) Remove turn signal canceling cam, upper bearing preload spring and thrust washer. Remove screw securing turn signal lever to signal switch and remove lever. Push hazard warning switch in and unscrew knob. Remove three screws securing signal switch assembly. Pull connector out of bracket on jacket tube. Wrap a piece of tape around upper part of connector and wires to prevent snagging when removing switch. Pull switch straight out with wire protector. To install, reverse removal procedure.

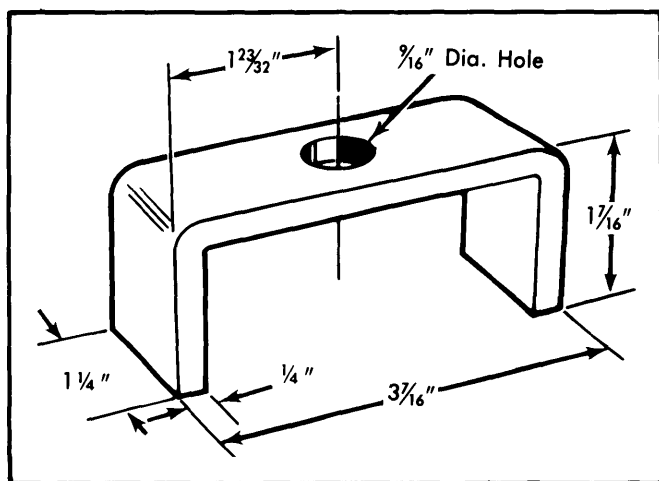

Fig. 1 Dimensions for Making a Lock Plate Depressor Tool

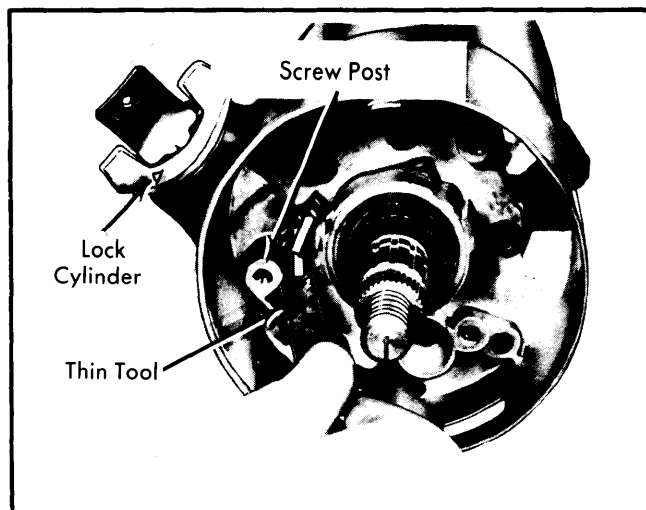

Fig. 2 Depressing Tab for Lock Cylinder Removal

STEERING COLUMN LOCK

All Models — Remove horn button, steering wheel, and directional signal indicator switch. Insert thin tool, small screwdriver, or knife blade into slot next to directional signal indicator switch retaining screw post and depress retainer at bottom of slot. Remove switch. To install, place cylinder in "LOCK" position and press into hole. Cylinder will snap into place.

IGNITION SWITCH

NOTE — To remove ignition switch, steering column must be removed from vehicle. See Steering Columns in this Section.

All Models — Remove horn button or pad, steering wheel, directional signal indicator switch, and lock cylinder. Pull up on lock cylinder-to-ignition switch connecting rod until a definite stop is reached. Move rod down one detent (which is the "LOCK" position). Remove two retaining screws, then remove switch. To install, reverse removal procedure.

JEEP

All Models

REMOVAL & INSTALLATION

HORN BUTTON & STEERING WHEEL

CAUTION — Before installing a new steering wheel shaft nut check for Standard American or metric thread. Metric threads have identifying groove in steering wheel splines. Standard American do not have grooves.

"CJ" Models — Disconnect negative battery cable. Position front wheels in straight-ahead position. Remove rubber boot and horn button by rotating button until lock tabs line up with notches in contact cup, then pull up and remove. Remove steering wheel nut and washer. **NOTE** — If equipped with sport

JEEP (Cont.)

wheel, remove button, nut and washer, button retaining ring, and horn contact ring. Remove contact cup retainer, contact cup, and contact plate. Remove contact pin and bushing from steering wheel. Scribe a mark on steering wheel and steering shaft to aid in reassembly. Remove steering wheel using a wheel puller (J-25115). To install, reverse removal procedure making sure bushing is fully seated. (J-21232) and remove wheel. To install, reverse removal procedure.

All Models (Exc. "CJ" Models) – Disconnect negative battery cable and place front wheels in straight-ahead position. Remove steering wheel spoke horn cover attaching screws from underside of steering wheel spoke, then remove cover. On sport style wheels, remove button, nut, washer, button retaining ring, and horn contact ring. Disconnect horn wire from switch in steering wheel cavity. Remove steering wheel nut and connector. Scribe a mark on steering wheel and steering shaft for reassembly reference. Install suitable wheel puller

DIRECTIONAL SIGNAL SWITCH & HAZARD FLASHER

All Models – 1) Disconnect negative battery cable. Remove horn contact trim cover by loosening bottom attaching screws. Disconnect horn wire from switch in steering wheel cavity by pulling quick disconnect connector. Remove steering wheel nut and note alignment of steering wheel to steering shaft index marks for reinstallation.

2) Remove steering wheel using a suitable puller (J-21232). Loosen anti-theft cover retaining screws and lift cover from column. **NOTE** – Screws do not need to be completely removed as they are held in the cover by plastic retainers. Use a suitable lock plate compressor tool (J-23653) to depress lock plate and pry small round wire snap ring from steering shaft groove.

3) Remove compressor tool, snap ring, lock plate, directional signal canceling cam, upper bearing preload spring and thrust washer from steering shaft. Place directional signal actuating lever in right turn position and remove lever. Depress hazard warning light switch and remove button by turning in a counterclockwise direction.

4) Remove directional signal wire harness connector block from mounting bracket on right side of lower column. On vehicles equipped with automatic transmission, use a stiff wire to depress lock tab retaining shift quadrant light wire in connector block. Remove directional signal switch retaining screws and pull signal switch and wire harness from column.

5) To install, guide wire harness into position and align signal switch assembly. **NOTE** – Actuating lever pivot must be correctly aligned and seated in upper housing pivot boss before retaining screws are installed. Install retaining screws to switch assembly. Install lever and check for correct operation. Position thrust washer, spring and canceling cam on upper end of steering shaft.

6) Align steering shaft and lock plate splines, then install lock plate while ensuring that canceling cam shaft protrudes through dogleg opening in lock plate. Install snap ring and anti-theft cover. Install hazard warning light button, steering wheel (aligning index marks) and steering wheel nut. Connect horn wire and battery cable. Install horn contact trim cover.

STEERING COLUMN LOCK

All Models – Remove horn button, steering wheel and directional signal switch as previously described. Position key in "ON" position, then depress key cylinder retaining tab and remove lock cylinder from housing. The retaining tab is accessible through slot adjacent to turn signal switch mounting boss. To install, position lock cylinder into housing until retaining tab snaps into position and secures lock cylinder to housing. Reverse removal procedure for installation of remaining components.

IGNITION SWITCH

All Models – 1) Remove horn button, steering wheel and directional signal switch as previously described. Position key in "OFF-UNLOCK" position and remove two switch mounting screws. Disconnect switch from remote rod, remove harness connector and remove switch from vehicle.

2) To install, position ignition switch next to column and move slider to extreme left position (toward steering wheel) on models with standard column and move slider to extreme right position (away from steering wheel) on models with tilt column.

3) Position actuator rod in slider hole and install switch to column. On tilt columns, move switch down column (away from steering wheel). On all models, install attaching screws taking care not to allow detent position to change. Install remaining components in reverse of removal procedure.