

WHEEL ALIGNMENT PROCEDURES

ADJUSTMENT CAUTIONS

Before making wheel alignment adjustments, check the following:

- 1) Wheel bearings must be properly adjusted.
- 2) Steering linkage and suspension must not have excessive looseness. Check for wear in tie rod ends and ball joints.
- 3) Tires should be approximately equal in tread wear and runout must not be excessive. Tires and wheels should be in balance, and inflated to manufacturer's specifications.
- 4) Vehicle must be at curb height with full fuel load, no passenger load, spare tire in place but no extra load in vehicle.
- 5) Vehicle must be on level floor with suspension settled. Bounce front and rear of vehicle several times and allow it to settle to normal running height.
- 6) If steering wheel is not centered with front wheels in straight ahead position, correct by shortening one tie rod adjusting sleeve and lengthening opposite sleeve equal amounts.
- 7) Ensure wheel lug nuts are tightened to manufacturer's specifications.

WHEEL LUG NUTS TIGHTENING SPECIFICATIONS (Cont.)

Application	Ft. Lbs.
GMC	
G1500.....	55-75
K1500.....	70-90
C & P1500, & G2500	75-100
All Remaining Models	
W/Single Wheels.....	90-120
W/Dual Wheels	110-140
W/Dual Wheels & 5/8" Studs	130-180
International Harvester	
1/2"-20 Lug Nuts.....	70-90
Jeep	
CJ Models.....	65-90
All Remaining Models	110-125
Plymouth	
All Models	
1/2"-20 Stud	85-125
5/8"-18 Stud (Flange Type Lug Nut)	300-350

WHEEL LUG NUTS TIGHTENING SPECIFICATIONS

Application	Ft. Lbs.
Chevrolet	
G10.....	70-90
K10.....	75-100
C & P10, & G20	75-100
All Remaining Models	
W/Single Wheels.....	90-120
W/Dual Wheels	110-140
W/Dual Wheels & 5/8" Studs	130-180
Dodge	
All Models (Exc. M500 & M600)	
1/2"-20 Stud	85-125
5/8"-18 Stud	
Cone Type Lug Nut	200
Flange Type Lug Nut	300-350
M500 & M600	450-500
Ford	
E 100 & 150.....	90
E 250 & 350	
W/Single Wheels.....	135
W/Dual Wheels	210
F 100, 150 & 250 (Incl. 4-WD).....	90
F 350	
W/Single Wheels.....	135
W/Dual Wheels	210
U-100 (Bronco).....	90

CAMBER

Camber is the tilting of the wheel, outward at either top or bottom, as viewed from the front of vehicle. When wheels tilt outward at the top from the centerline of vehicle, camber is said to be positive. When wheels tilt inward at the top, camber is said to be negative. Amount of tilt is measured in degrees from vertical.

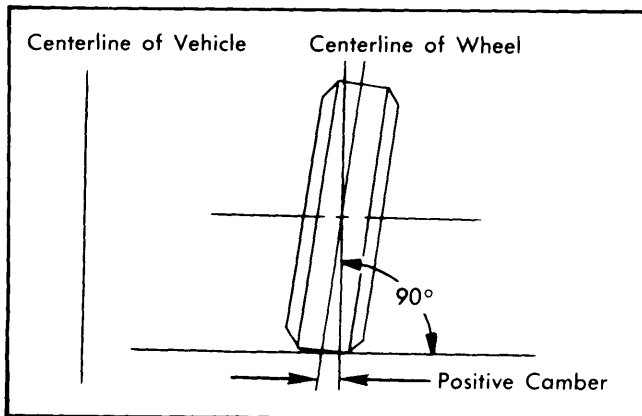

Fig. 1 Camber Angle

CASTER

Caster is the tilting of front steering axis, either forward or backward from vertical, as viewed from side of vehicle. When axis is tilted backward from vertical, caster is said to be positive, creating a trailing action on front wheels. When axis is tilted forward, caster is negative, causing a leading action on front wheels.

Wheel Alignment

WHEEL ALIGNMENT PROCEDURES (Cont.)

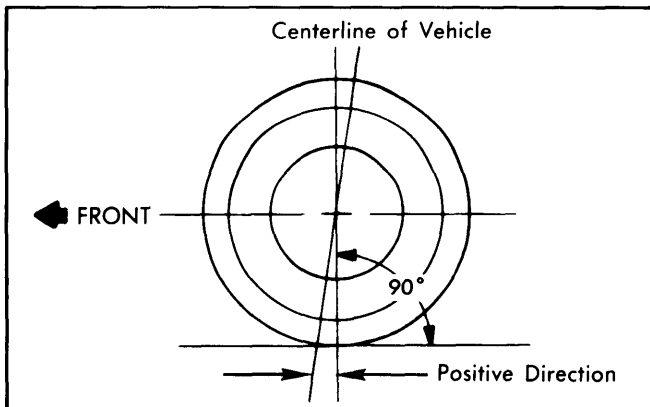

Fig. 2 Caster Angle

TOE-IN ADJUSTMENT

Measure toe-in with front wheels in straight ahead position and steering wheel centered. Adjust toe-in by loosening clamps and turning adjusting sleeve or adjustable end on right and left tie rods equally and in opposite directions to maintain steering wheel in centered position. **CAUTION** — Face of tie rod end must be parallel with machined surface of steering rod end to prevent cocking and binding of the ball end in service. When tightening clamps, make certain that that clamp bolts are positioned so there will be no interference with other parts throughout entire travel of linkage.

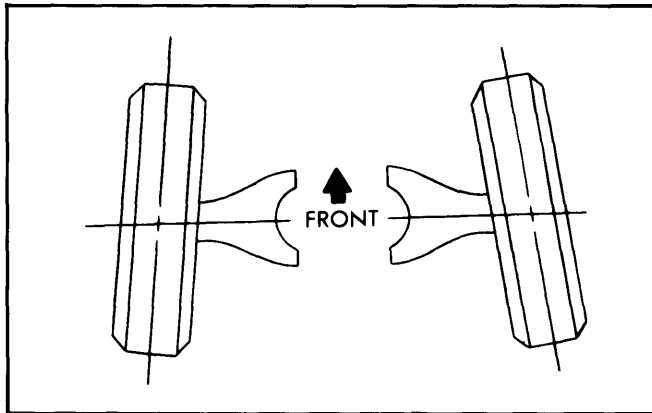

Fig. 3 Wheel Toe-In

TOE-OUT ON TURNS

Toe-out check is a check for bent or damaged parts, and not a service adjustment. With caster, camber, and toe-in properly adjusted, check toe-out with weight of car on wheels (use full-floating turn table under each wheel), repeating test with each wheel positioned for right and left turns. Incorrect toe-out generally indicates a bent steering arm. Replace arm and recheck all wheel alignment adjustments. **CAUTION** — Do not attempt to correct by straightening parts.

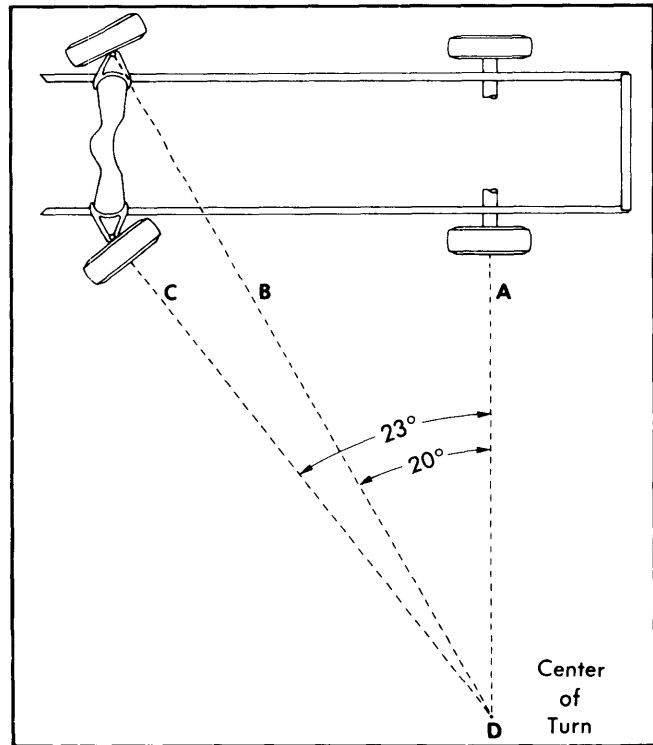

Fig. 4 Wheel Toe-Out

STEERING AXIS INCLINATION

This is a check for bent or damaged parts, and not a service adjustment. Vehicle must be level (crosswise and lengthwise) and camber should be properly adjusted. If camber cannot be brought within limits and steering axis inclination is correct, steering knuckle is bent. If camber and steering axis inclination are both incorrect by approximately the same amount, upper and lower control arms are bent. Replace parts, and recheck all front end adjustments. **CAUTION** — Do not attempt to correct by straightening parts.

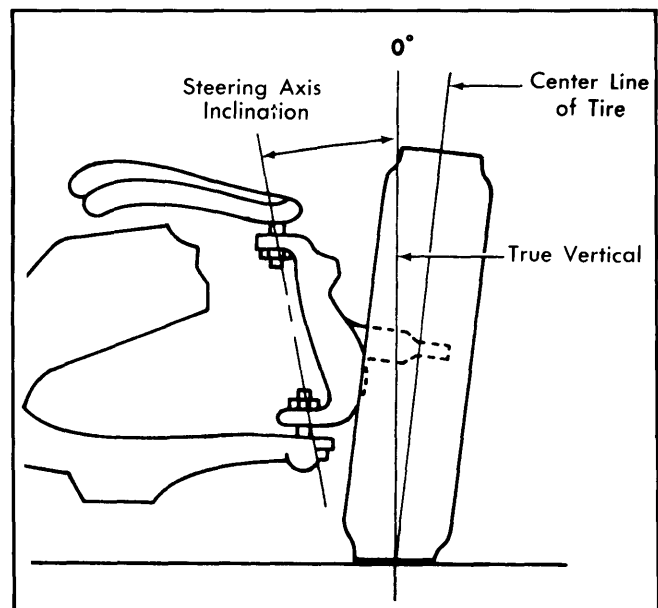

Fig. 5 Steering Axis Inclination