

GENERAL MOTORS SLIDING CALIPER DISCS

Chevrolet (All Models W/Hydro-Boost)
GMC (All Models W/Hydro-Boost)

DESCRIPTION

Sliding caliper disc brake assemblies are single piston type. Front calipers are mounted to a one piece steering knuckle, steering arm and support member. Rear calipers are mounted to an adapter bolted to drive axle. As brake pedal is depressed, hydraulic pressure is passed to brake caliper piston. This force is transmitted to inboard disc pad and against inner braking surface. As force increases against inner side, caliper slides inward, providing vise-like clamping action on rotor.

ADJUSTMENT & SERVICING

DISC PAD ADJUSTMENT

Pad wear is automatically compensated for by piston moving outward in cylinder bore; therefore, no disc pad adjustment in service is required. **NOTE** — *Inspect condition of disc pads whenever wheels are removed.* If any pad is worn to within $\frac{1}{32}$ " of rivet heads, replace complete set.

PARKING BRAKE

See *Parking Brake Adjustment in General Motors Single Anchor Brake System in this Section.*

BLEEDING SYSTEM

See *Hydraulic Brake Bleeding in this Section.*

REMOVAL & INSTALLATION

DISC BRAKE PADS

Removal — 1) To prevent master cylinder overflow when caliper is depressed, remove two-thirds of the brake fluid from master cylinder. Raise vehicle and remove wheel. Place a large "C" clamp on caliper and tighten clamp to bottom piston in cylinder bore. Remove clamp.

2) Remove key retaining screw, then using a brass rod and a light hammer, drive out caliper support key and caliper support spring. Remove caliper by pushing down against mount and rotating upward and away from mount. **CAUTION** — *Support caliper with wire. Do Not let caliper hang with weight on brake hose.*

3) Remove outer disc pad from caliper. It may be necessary to tap pad to loosen pad flange from caliper. Remove inner disc pad from mount, then remove disc pad anti-rattle clip.

Installation — 1) Lubricate caliper and mount sliding surfaces with silicone lubricant. Install new anti-rattle clip in mount. Place lower end of inner pad into mount and against anti-rattle clip, then slide upper end of pad into position. Be sure clip is still in correct position.

2) With caliper piston fully bottomed in cylinder bore, position outer pad on caliper and press tabs into place. If pad cannot be properly positioned by hand, use a large "C" clamp, taking care not to mar lining.

3) Install caliper on mount by pivoting caliper around upper mounting surface. While holding caliper against upper surface of mount, install new caliper support spring and new caliper support key. Using a soft hammer, drive key and spring into position, then install key retaining screw. Refill master cylinder. Install wheel and lower vehicle.

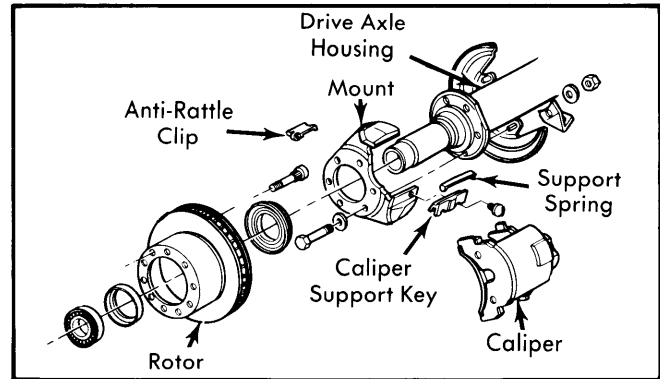

Fig. 1 Rear Sliding Caliper Disc Brake Components

BRAKE CALIPER

Removal & Installation — Caliper removal and installation procedures are same as for disc pad replacement, except it will be necessary to disconnect brake hose.

OVERHAUL

BRAKE CALIPER

Disassembly — 1) With caliper assembly clean, to prevent contamination, remove plug from caliper inlet port and drain fluid from caliper housing. Place caliper assembly on bench with piston side up and place several shop towels between piston and outer legs of caliper housing.

2) Slowly and carefully apply air pressure to caliper inlet port until piston comes out of caliper housing. **CAUTION** — *Use low air pressure to remove piston. High pressure may cause piston to pop out with considerable force. If piston is seized, tap lightly on end of piston with soft-faced hammer to free piston.*

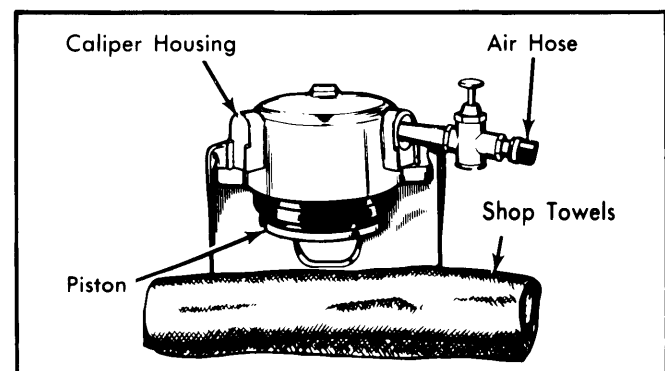

Fig. 2 Using Compressed Air to Remove Caliper Piston

3) Remove boot from piston and seal from cylinder bore. Clean caliper housing and piston with denatured alcohol.

GENERAL MOTORS SLIDING CALIPER DISCS (Cont.)

Check cylinder bore, seal groove, and boot groove for damage and excessive wear. Replace piston if pitted.

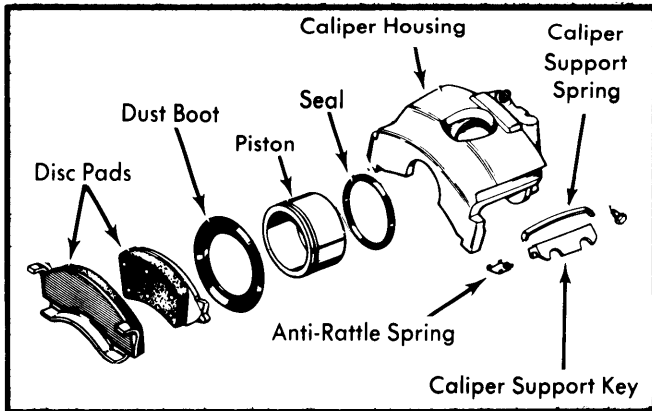

Fig. 3 Exploded View of Sliding Caliper Assembly

Reassembly — To assemble caliper, soak all parts in suitable brake fluid and reverse disassembly procedure. Use large C-clamp to seat piston in cylinder bore.

DISC ROTOR

Lateral Runout — Adjust wheel bearings until all endplay is eliminated. Attach dial indicator with contact tip of indicator on braking surface approximately one inch from rotor edge. Set indicator to zero and turn rotor through one complete revolution, noting indicator reading.

Parallelism — Check thickness of rotor at four or more points around circumference of rotor. Make all measurements at same distance from edge of rotor. If thickness variation is excessive, refinish or replace rotor as necessary.

TIGHTENING SPECIFICATIONS

Application	Ft. Lbs.
Brake Hose-to-Caliper.....	22
Support Key Retaining Screw.....	18
Application	Inch Lbs.
Hydraulic Line-to-Brake Hose	150
Bleeder Valve Screws	100

DISC BRAKE ROTOR SPECIFICATIONS

Application	Disc Diameter	Lateral Runout	Parallelism	Original Thickness	Minimum Refinish Thickness	Discard Thickness
Front (Drum Rear)	12.50	.004"	.0005"	1.530"	1.480"	1.465"
Front (Disc Rear)	14.25"	.004"	.0005"	1.530"	1.480"	1.465"
Rear ①	13.75"	.004"	.0005"	1.530"	1.480"	1.465"

① — Optional on "P" models and Motor Home Chassis