

BENDIX HYDRO-BOOST

Chevrolet
Dodge
GMC
Plymouth

NOTE — The Bendix Hydro-Boost is standard on some models and optional on others. See the BRAKE APPLICATION tables at the beginning of this section.

DESCRIPTION

System utilizes power steering pump fluid pressure to operate booster. Assembly contains an open center spool valve which controls pump pressure magnitude during braking, a lever mechanism to control position of valve, and a boost piston to provide force necessary to operate master cylinder. Unit also has a reserve system which stores sufficient fluid under pressure to provide at least two braking applications in case fluid flow from power steering pump is not available. Brakes can also be applied manually if reserve system is depleted.

OPERATION

RELEASED POSITION (NO BRAKING)

In this position, spool valve return spring holds spool valve open. In open position, spool valve provides unrestricted fluid flow between power steering pump and power steering gear. Fluid pressure is blocked from entering boost pressure chamber by lands on spool valve. As fluid pressure increases with steering demand, it has no effect on boost pressure chamber. Boost pressure chamber is vented through spool valve, to pump return port, and back to power steering pump.

BRAKING POSITION

As brake pedal is depressed, it moves pedal rod and initiates movement of spool valve. This closes fluid return port to pump from boost chamber, and admits fluid into boost chamber from pressure port. Additional valve movement restricts flow between pump and steering gear, causing pump to increase fluid pressure to maintain flow rate to steering gear. As fluid pressure increases in boost chamber, it forces piston forward actuating master cylinder piston, resulting in brake application. If fluid pressure is required for steering while braking, pump pressure will rise and spool valve will shift in an open direction allowing more fluid to flow to steering gear.

RESERVE SYSTEM

1) System consists of a charging valve, accumulator valve, and a spring loaded accumulator. Accumulator is integral with booster unit. System is open to pressure port of booster unit. Charging valve has an orifice and ball check. Fluid from pump passes through orifice in valve, and if pressure exceeds pressure in accumulator, it unseats ball check valve and enters accumulator. Ball check valve prevents reverse flow when accumulator pressure is greater.

2) Accumulator valve is a poppet type valve held closed by pressure stored in accumulator. An actuator on spool valve sleeve opens accumulator valve when a stop with no pump pressure is made that requires use of reserve pressure. Fluid pressure can also enter accumulator from boost chamber through accumulator valve, when boost chamber pressure ex-

ceeds accumulator pressure. A pressure relief valve vents accumulator to pump return port when pressure in accumulator exceeds approximately 1600 psi.

ADJUSTMENT

BRAKE PEDAL

Chevrolet & GMC (MHC Only) — With brake return spring installed, brake pedal should return hard into rubber stop, and master cylinder and pedal rod lever should be at full return. Install pre-assembled brake pedal rod assembly (rod, end and boot). Adjust brake pedal rod to 31.00" and adjust rod end until pedal free play is .06-.36". Fasten boot to floor pan and compress to an installed height of 2.54". Pedal travel (with engine off and accumulator depleted) should not be more than 6" under a 90 lb. load.

Chevrolet & GMC (Remaining Models) — 1) Make adjustment in linkage until pedal travel is as specified. Pedal travel is distance pedal moves toward floor from a fully released position. Pump pedal a minimum of 3 times with engine off before making measurement.

2) Specified pedal travel is 3½" on all models except four-wheel disc brake models. Pedal travel is 6" on all four-wheel disc brake models.

Dodge ("M" Models) — 1) Disconnect wiring at rear of stop light switch. Loosen lock nut at switch and loosen switch until plunger is no longer contacting pedal. Disconnect pedal return spring. Loosen pedal stop lock nut and remove shouldered push rod end bolt and pedal return spring bracket.

2) Place a .010-.015" spacer between pedal and stop. Turn stop in or out until shouldered bolt can be easily inserted in pedal and push rod. Install return spring bracket and tighten pedal stop nut. Remove spacer and connect return spring. Tighten stop light switch until plunger just contacts pedal and then turn an additional 2 1/2 turns. Tighten switch lock nut and connect wiring.

NOTE — Pedal adjustment procedures for Dodge and Plymouth models (except "M" models) was not available from manufacturer at time of publication.

TESTING

NOTE — Hydroboost cannot cause noisy brakes, fading brake pedal, or pulling brakes. If one of these conditions exists, other components of brake system are at fault.

PRELIMINARY CHECKS

Check fluid levels in master cylinder and power steering pump. Check power steering pump belt tension, and adjust if necessary. Inspect all power steering hoses for leaks or kinks. If fluid smells burned, check hoses or cooler for restrictions. Check and adjust engine idle speed. Check power steering hydraulic fluid for aeration (shown by bubble in fluid), bleed system if necessary.

NOTE — If problem cannot be found in preliminary steps, make following tests. If unit is found to be operating properly, check areas of brake system that might cause condition. See Hydraulic Brake Trouble Shooting in this section.

BENDIX HYDRO-BOOST (Cont.)

HYDRO-BOOST DIAGNOSIS

NORMAL OPERATING CHARACTERISTICS

Brake pedal application of the Hydro-Boost system differs in some respects from a vacuum type power brake system in the following manner:

- | | |
|---|--|
| <p>1) As pedal is depressed, a slight power steering pump noise may be heard until booster run-out.</p> <p>2) Application of pedal through run-out may not necessarily be smooth due to internal ratio change. It is possible to push the pedal past run-out because the pedal ratio is higher. The pedal becomes hard at the end of vacuum booster runout.</p> | <p>3) On the first full application of the brake pedal, a slight hissing sound may be heard. The hiss is the accumulator charging and the noise should go away in a short period of time.</p> <p>4) As the brake pedal is depressed hard, a slight kick-back of pedal may be felt.</p> <p>5) If the vehicle is started with the pedal depressed, the pedal will fall away slightly then return to approximately the same position.</p> |
|---|--|

CONDITION

NO BOOST – HARD PEDAL

Preliminary Check – With engine stopped, depress brake pedal several times. This will eliminate all accumulator reserve from system. Hold the brake pedal depressed with medium pressure (25-35 lbs.) and start engine. If the unit is operating correctly, the brake pedal will fall slightly, then push back against driver's foot, remaining at about the same position. If the booster is not operating correctly, the trouble may be one of the following causes:

POSSIBLE CAUSE

CORRECTION

- | | |
|---|--|
| <p>1) Loose or broken power steering pump belt.</p> <p>2) No fluid in power steering reservoir.</p> <p>3) Leaks in power steering, booster or accumulator hoses.</p> <p>4) Leaks at tube fittings, power steering booster or accumulator connections.</p> <p>5) External leakage at accumulator.</p> <p>6) Faulty booster piston seal causing leakage at booster flange vent.</p> <p>7) Faulty booster input rod seal with leakage at input rod end.</p> <p>8) Faulty booster cover seal with leakage between housing and cover.</p> <p>9) Faulty booster spool plug seal.</p> <p>10) Internal leakage in booster.</p> <p>11) Contamination in power steering fluid.</p> <p>12) Incorrect routing of hydraulic lines.</p> | <p>1) Tighten or replace belt.</p> <p>2) Fill reservoir and check for internal leaks.</p> <p>3) Replace defective components.</p> <p>4) Tighten fittings or replace tube seals, if defective.</p> <p>5) Replace booster assembly.</p> <p>6) Replace all booster seals.</p> <p>7) Replace all booster seals.</p> <p>8) Replace all booster seals.</p> <p>9) Replace all booster seals.</p> <p>10) Replace booster assembly.</p> <p>11) Flush power steering system and replace with new fluid.</p> <p>12) Re-route hydraulic lines.</p> |
|---|--|

Power Brake Units

BENDIX HYDRO-BOOST (Cont.)

HYDRO-BOOST DIAGNOSIS	
CONDITION	
POWER STEERING PUMP NOISY ON BRAKE APPLICATION	
POSSIBLE CAUSE	CORRECTION
1) Insufficient fluid in pump reservoir.	1) If fluid level decreases approximately 1/2" on brake application, refill to proper level. If fluid is foamy, let vehicle stand for about one hour; then, bleed power steering hydraulic system as outlined in this article.
CONDITION	
BRAKE PEDAL PULLS DOWN SLIGHTLY ON ENGINE START	
POSSIBLE CAUSE	CORRECTION
1) Restriction in gear or booster return lines.	1) Replace lines or reposition to eliminate restriction.
CONDITION	
ACCUMULATOR LEAKDOWN – SYSTEM DOES NOT HOLD CHARGE	
<p>Preliminary Check – Start engine and turn steering wheel until the wheels slightly contact wheel stops. Hold for a maximum of five seconds. Now release steering wheel and turn off engine. Depress and release brake pedal. There should be a minimum of three power assisted brake applications before a hard pedal is obtained.</p> <p>Re-start engine and turn steering wheel until the wheels lightly contact wheel stops. There should be a light hissing sound as the accumulator is charged. Hold steering wheel lightly against stop for a maximum of five seconds. Release steering wheel and turn off engine. Wait one hour and apply brake pedal (do not re-start engine). There still should be a minimum of three power assisted brake applications before a hard pedal is obtained.</p> <p>If either of these preliminary checks indicate that the accumulator is not holding a charge, the trouble may be in one of the following causes:</p>	
POSSIBLE CAUSE	CORRECTION
1) External leakage at accumulator.	1) Replace booster assembly.
2) Internal leakage at accumulator.	2) Replace booster assembly.
3) Internal leakage at booster accumulator valve (if accumulator is not leaking externally or internally).	3) Replace all booster seals and accumulator valves.
CONDITION	
BRAKES GRAB ON APPLICATION	
POSSIBLE CAUSE	CORRECTION
1) Broken spool return spring.	1) Replace spring.
2) Faulty spool action caused by contamination in system.	2) Inspect, clean and replace all booster seals.

BENDIX HYDRO-BOOST (Cont.)

HYDRO-BOOST DIAGNOSIS	
CONDITION	
BOOSTER CHATTER – PEDAL VIBRATES	
POSSIBLE CAUSE	CORRECTION
1) Power steering pump belt slips.	1) Tighten belt.
2) Low fluid level in power steering pump reservoir.	2) Fill reservoir and check for external leaks.
3) Faulty spool operation caused by contamination in system.	3) Inspect, clean and replace all booster seals.
4) Excessive contamination in power steering fluid.	4) Flush power steering fluid from system and replace with new power steering fluid.
5) Air in power steering fluid.	5) Allow vehicle to stand for one hour; then bleed power steering hydraulic system as outlined in this article.

CONDITION	
SLOW BRAKE PEDAL RETURN	
POSSIBLE CAUSE	CORRECTION
1) Excessive seal friction in booster.	1) Replace all booster seals.
2) Faulty spool action.	2) Clean spool and replace all booster seals.
3) Broken piston return spring.	3) Replace spring.
4) Restriction in return line from booster to pump reservoir.	4) Replace line.
5) Broken spool return spring.	5) Replace spring.
6) Excessive pedal pivot friction.	6) Lubricate pivot bushing or replace bushing.

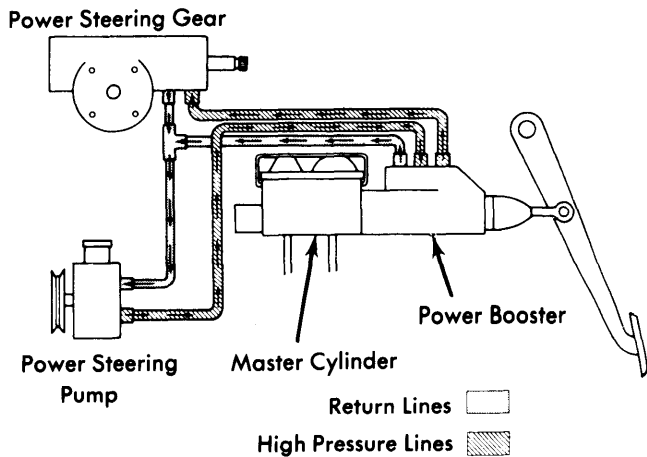

Fig. 1 Hydro-Boost Fluid Flow Chart

REMOVAL & INSTALLATION

CHEVROLET & GMC

Removal – 1) Depress and release brake pedal several times to be sure that all pressure is discharged from accumulator prior to disconnecting hoses from booster. Raise Motor Home Chassis on hoist; all others, leave on ground. Clean all dirt from booster at hydraulic line connections and master cylinder. Remove nuts that secure master cylinder to booster and support bracket. Support master cylinder, and cover exposed end with clean cloth.

NOTE – In most cases, it is not necessary to disconnect master cylinder hydraulic lines to remove booster unit.

2) On all models except Motor Home Chassis, remove booster pedal push rod cotter pin and disconnect push rod from brake

BENDIX HYDRO-BOOST (Cont.)

pedal ("C" and "K" models) or booster bracket pivot lever ("G" and "P" models). Remove booster support bracket ("C" and "K" models) or support braces ("G" and "P" models). Remove booster bracket-to-firewall or support bracket nuts and remove booster assembly.

3) On Motor Home Chassis, remove cotter pin, nut and bolt that secure operating lever to vertical brake rod. Remove the six nuts and bolts that secure booster linkage bracket to front and rear support brackets, and remove booster from vehicle by sliding booster off rear support studs. Remove cotter pin, nut, and bolt that secures operating lever to pedal rod. Remove brake pedal rod lever nut and bolt and then remove lever, sleeve and bushings.

Installation — To install, reverse removal procedure noting the following: Lubricate pedal rod and linkage pivot bolts, pins, sleeves and bushings with suitable lubricant (Delco Brake Lube 5450032). Bleed booster/power steering hydraulic system. **NOTE** — *This is a separate procedure from bleeding hydraulic brake system. See Bleeding Hydroboost System in this Article.* Check brake pedal and stoplamp switch adjustment.

DODGE & PLYMOUTH

Removal — Depress and release brake pedal several times to be sure that all pressure is discharged from accumulator. Disconnect and plug hoses from booster. Remove master cylinder nuts and lay master cylinder to side without kinking lines. Disconnect brake return spring. Remove brake pedal push rod bolt, remove mounting nuts and booster.

Installation — To install unit, reverse removal procedure. Tighten all nuts and hose connections. Bleed booster/power steering hydraulic system. **NOTE** — *This a separate procedure from bleeding hydraulic system. See Bleeding Hydroboost System in this article.* Check brake pedal and stop lamp switch adjustment.

BLEEDING HYDROBOOST SYSTEM

CHEVROLET & GMC

NOTE — *If power steering fluid has foamed due to low fluid level, it will be necessary to park vehicle for approximately one hour (reservoir cap loose) so that foam can dissipate.*

1) Raise front of vehicle on a hoist so that tires are clear of floor. Check reservoir and fill with suitable power steering fluid (GM Power Steering Fluid). **NOTE** — *Leave reservoir cap off during entire bleed procedure.* Install a remote control starter switch so that engine can be cranked but not started. **CAUTION** — *Whenever engine is cranked with a remote starter, or other means, distributor primary lead must be disconnected from negative post on coil.*

2) Crank engine for four to five seconds while pouring fluid into reservoir. Fill reservoir and crank engine until system will no longer accept fluid. It is normal that fluid may spill from filler tube when cranking stops. Remove remote control starter switch and reconnect distributor wire. Start engine and run for two seconds. Check and refill reservoir if necessary.

3) Start engine and depress brake pedal several times while rotating steering wheel from "Stop" to "Stop". Turn engine off and then pump brake pedal four to five times to deplete accumulator pressure. Check and refill reservoir if necessary. Repeat step 3). Install reservoir cap.

DODGE & PLYMOUTH

1) Check power steering pump reservoir and fill with suitable power steering fluid (MOPAR Power Steering Fluid). Allow fluid to remain undisturbed for two minutes. Leave reservoir cap off during bleeding operation.

2) Start engine and run for ten seconds. Check fluid level and add fluid if necessary. Repeat procedure until fluid level remains constant. Raise front of vehicle and allow tires to clear floor. Start engine and run at 1500 RPM. Apply and release brakes several times, at the same time turn wheels back and forth, lock to lock. Turn off engine and check fluid level. Add fluid if necessary.

3) Lower vehicle. Start engine and run at 1500 RPM. Apply and release brake pedal several times, at the same time turn front wheels back and forth, lock to lock. Turn off engine and check fluid level. Add fluid if necessary. If fluid level is low, repeat bleeding procedure. Place cover on reservoir.

BLEEDING BRAKE CYLINDERS

See Hydraulic Brake Bleeding in this Section.

OVERHAUL

Disassembly — 1) Secure unit in vise (bracket end up) and use chisel to cut bracket nut that secures linkage bracket to power section. Cut nut at slot in threaded section to prevent damage to threads. Remove linkage bracket from unit.

2) Remove pedal rod boot and place rod retainer shearing tool (see tool chart for number) over rod. Place a punch through pedal rod from lower side of tool and push punch on through to rest on higher side of tool. Lift up on punch to shear pedal rod retainer. Remove pedal rod.

3) Remove remnants of rubber grommet from groove near end of pedal rod and from groove inside input rod end. Disengage tabs of spring retainer from ledge inside opening near master cylinder mounting flange of booster. Remove retainer and piston return spring from opening. Pull straight out on output push rod to remove push rod and push rod retainer from inside booster piston.

4) Press in on spool plug, and insert a small punch into hole on top of housing (see illustration). This unseats one side of spool plug snap ring from its groove in bore; remove snap ring from bore. Use pliers to remove spool plug from bore. Remove and discard "O" ring seal from plug. Remove spool spring from bore.

BENDIX HYDRO-BOOST (Cont.)

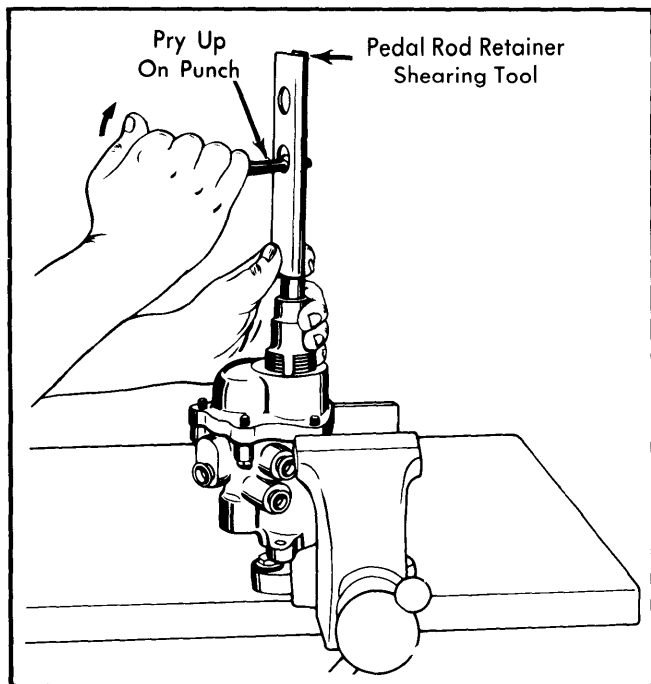

Fig. 2 Procedure for Removing Booster Pedal Rod

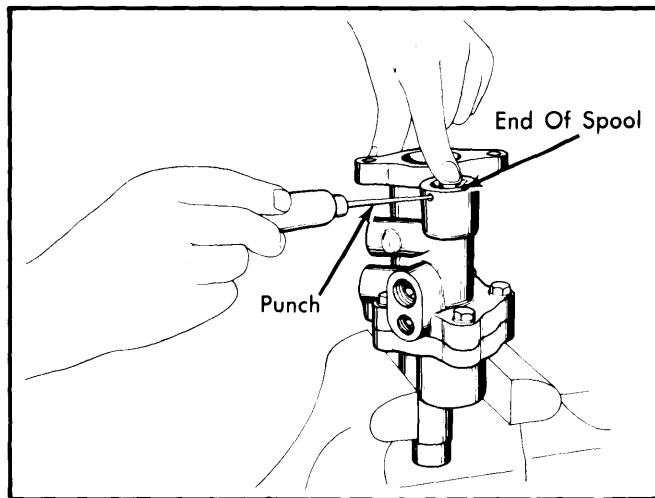

Fig. 4 Removing Spool Plug from Booster

5) Place booster cover in soft jawed vise and remove the five screws that secure booster housing to cover. Remove booster assembly from vise and while holding unit over a pan, separate cover from housing. Remove large seal ring from groove in cover; discard seal ring.

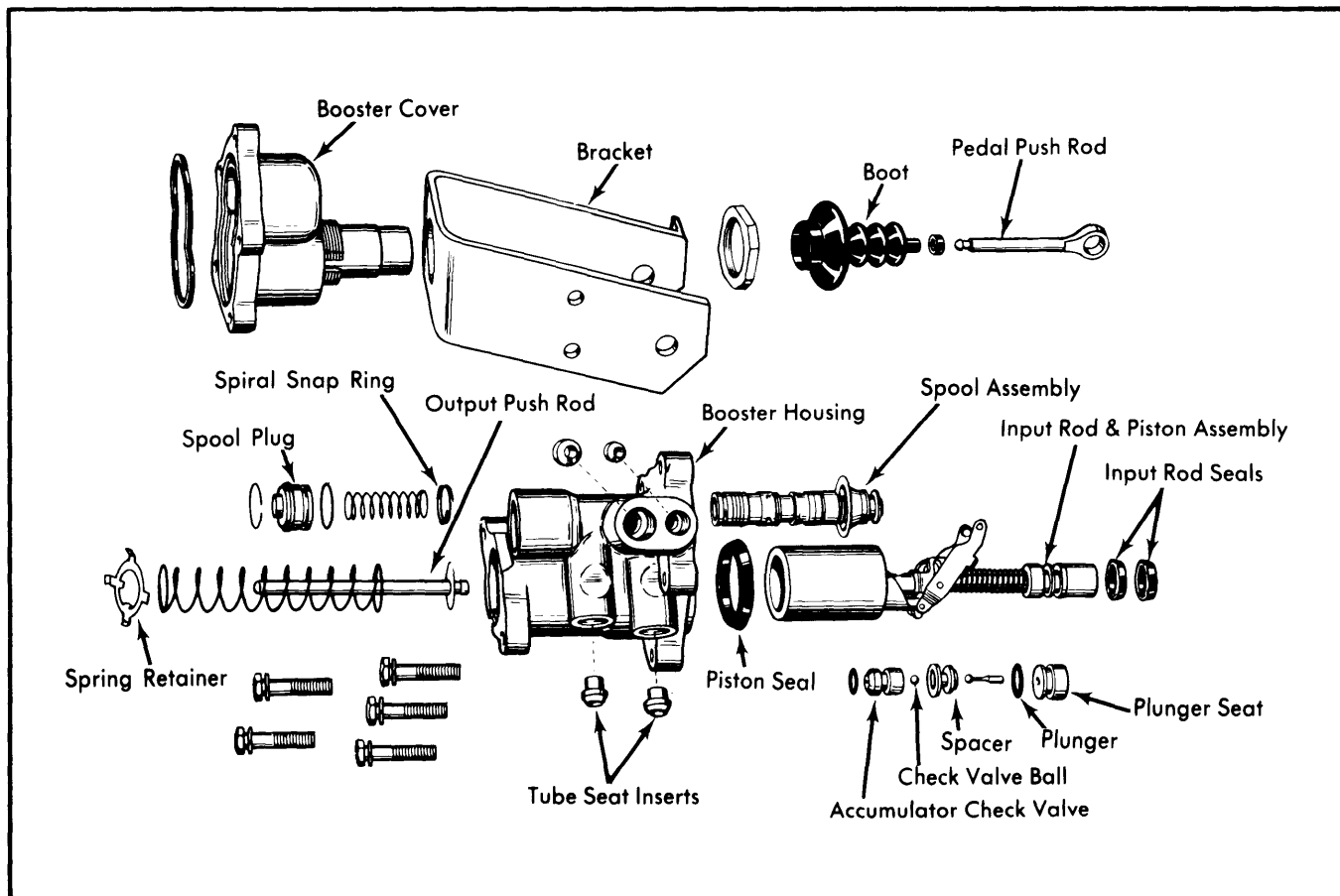

Fig. 3 Exploded View of Bendix Hydro-Boost Assembly Components (Unit with External Accumulator Shown)

Power Brake Units

BENDIX HYDRO-BOOST (Cont.)

6) Remove input rod and piston assembly, and spool assembly from booster housing. Remove input rod seals and input rod end, and piston seat from piston bore in housing; discard seals. Remove plunger seat, spacer and ball from accumulator valve bore in flange of booster housing. Remove "O" ring from seat; discard "O" ring.

7) Thread a screw extractor into opening in check valve in bottom of accumulator valve bore, and remove check valve from bottom of bore. Discard check valve and "O" ring. Use a 1/4" or 3/16" spiral flute type screw extractor to remove tube seats from booster ports.

Cleaning & Inspection - 1) Clean all metal parts in a suitable solvent. Inspect valve spool and valve spool bore in booster housing for corrosion, nicks, scoring or other damage. Discoloration of spool or bore, particularly in grooves, is not harmful.

2) If valve spool or valve spool bore has nicks or scoring that can be felt with a fingernail, particularly on the lands, spool and housing should be replaced as an assembly. Spool and housing should never be replaced independently, always as an assembly.

3) Inspect input rod, piston assembly, and piston bore for corrosion, nicks, scoring or other damage. Replace damaged parts.

Reassembly - 1) Be sure that all parts are absolutely clean. Lubricate all seals and metal friction points with power steering fluid. Position a new tube seat in each booster port and screw a spare tube nut in each port to press seat down.

CAUTION - Do not completely tighten tube nut into port. Distortion of new tube seat might result.

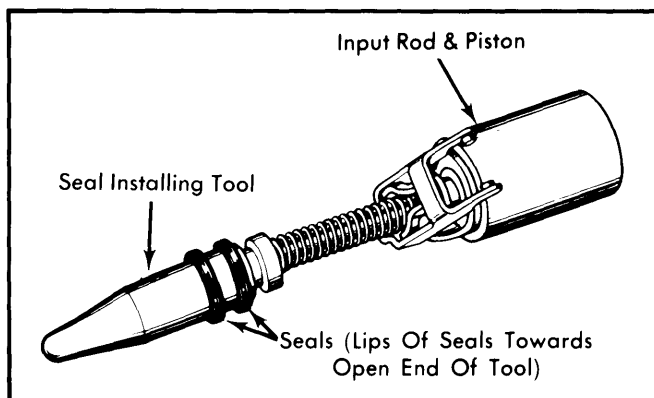

Fig. 5 Using Special Tool to Install Input Rod Seals

2) Remove spare tube nuts and check for aluminum chips in ports. Remove any foreign matter. Coat piston bore and new piston seal with clean power steering fluid and assemble seal

in bore. Lip of seal must be toward rear (away from master cylinder mounting flange). Lubricate input rod end, new input rod seals and seal installer tool (see tool chart for number) with clean power steering fluid. Slide seals on tool with lip of cups toward open end of tool (see illustration). Slide tool over input rod end and down to second groove. Then slide forward seal off tool and into groove. Assemble other seal in first groove. Make sure both seals are fully seated.

3) Lubricate piston and piston installation tool (see tool chart for number) with clean power steering fluid. Insert large end of tool into piston and slide tool and piston into piston bore and through piston seal. Assemble new "O" ring onto new accumulator check valve, and dip assembly in clean power steering fluid. Insert check valve into accumulator valve recess in housing flange. Assemble new ball and spacer in same recess.

4) Assemble new "O" ring onto charging valve plunger seat and insert plunger into seat. Dip assembly in clean power steering fluid and insert it into charging valve recess. Dip spool assembly in clean power steering fluid, and insert assembly into spool bore in housing. Be sure that pivot pins on upper end of input rod lever assembly are engaged in groove in sleeve. Remove tool from piston assembly.

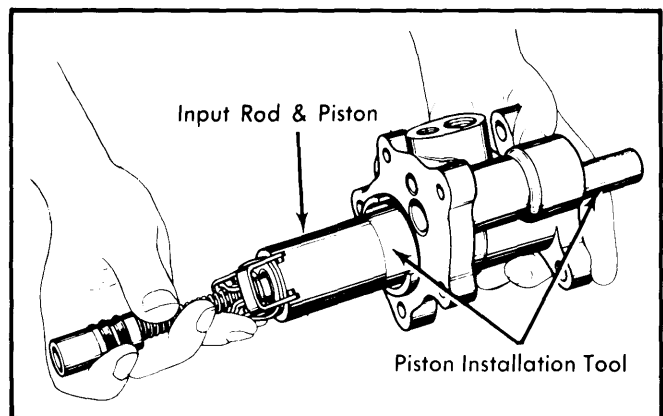

Fig. 6 Installing Input Rod Assembly into Booster

5) Position a new housing seal in groove in housing cover. Join booster housing and cover and secure with five screws. Tighten screws to 18-26 ft. lbs. Assemble new "O" ring seal on spool plug. Insert spool spring and spool plug in forward end of spool bore. Press in on plug and assemble plug snap ring in groove in bore.

6) Position linkage bracket on booster. Tab on inside diameter of large hole in bracket should fit into a slot in threaded portion of booster hub. Install new bracket nut with staking groove outward on threaded hub of adapter. Using a special deep socket (see tool chart for number) and torque wrench, tighten nut to 95-120 ft. lbs. Use a hammer and small punch inserted into staking groove of nut, at slot in booster hub, to stake nut in place. Make sure that outer thread of nut is upset.

BENDIX HYDRO-BOOST (Cont.)

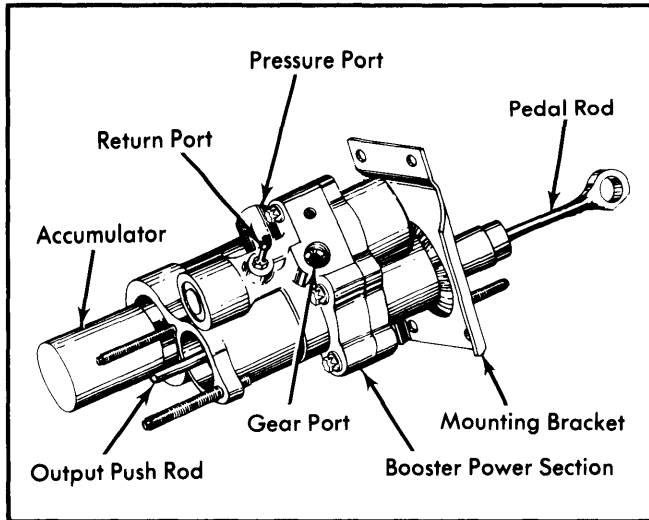

Fig. 7 Bendix Hydro-Boost Assembly

7) Assemble a new boot on pedal rod. Then assemble a new grommet in groove near end of pedal rod. Moisten grommet with water and insert grommet end of pedal rod into input rod end of booster housing. Push on end of pedal rod to seat grommet in groove inside housing. **NOTE** — When grommet is fully seated, pedal rod will rotate freely with no binding. Slide boot on pedal rod and assemble large end of boot on hub of power section.

TOOL NUMBER CHART

Application	GM Number	Chry. Number
Retainer Shearer.....	J-24569.....	C-4396
Seal Installing Tool.....	J-24553.....	C-4394
Piston Installing Tool.....	J-24551.....	C-4393
Special Deep Socket.....	J-24554.....	C-4395