

FORD MOTOR CO.

Ford F250 (4WD Only)

DESCRIPTION

Non-Integral power steering assist system, used with standard steering gear, consists of a pump, hydraulic hoses, a control valve, and a linkage mounted power cylinder. Power cylinder is mounted between front axle assembly and a tie rod. Control valve is mounted between pitman arm and steering knuckle arm, allowing it to act as a drag link. Movement of the pitman arm actuates the control valve, which in turn directs fluid pressure to the spool valve in the power cylinder. This fluid flow provides unequal pressures on the two sides of the piston within the power cylinder, thus creating a hydraulic assist to manual steering effort.

LUBRICATION, TROUBLE SHOOTING & TESTING

See *Power Steering General Servicing* in this section.

ADJUSTMENT

See *Gemmer/Ross Worm & Roller manual steering gear* article in this section.

REMOVAL & INSTALLATION

CONTROL VALVE/POWER CYLINDER

Removal — Remove cotter pins and castellated nuts from ball studs which attach control valve to pitman arm, and the tie rods to idler arm. Remove control valve from pitman arm, and tie rods from idler arm. Remove power cylinder-to-bracket attaching hardware. Disconnect hydraulic lines at power steering pump, and mark for reassembly reference. Remove idler arm bracket attaching bolts, and remove idler arm, hoses, power cylinder, and control valve from vehicle as an assembly.

Installation — Rest control valve, power cylinder, hydraulic hoses, and idler arm assembly on engine crossmember. Attach idler arm bracket to frame crossmember, then connect hydraulic lines to power steering pump. Attach power cylinder to front bracket, and connect control valve to pitman arm. Connect tie rods to idler arm. Tighten all nuts, bolts, and fittings securely, and bleed system.

OVERHAUL

POWER CYLINDER

NOTE — Internal components, other than rod seals and tube seats, are serviced as a complete cylinder assembly only.

Disassembly & Reassembly — Drain fluid from cylinder and remove snap ring using snap ring pliers. Clamp cylinder in a vise and apply air pressure to one fluid port while covering other port with a finger. At the same time, hold a towel around rod to prevent washer and seal from coming free.

Remove the neoprene seal from bore of cylinder cap with two small screwdrivers. To reassemble, reverse disassembly procedure while using new components and making sure snap ring is firmly seated.

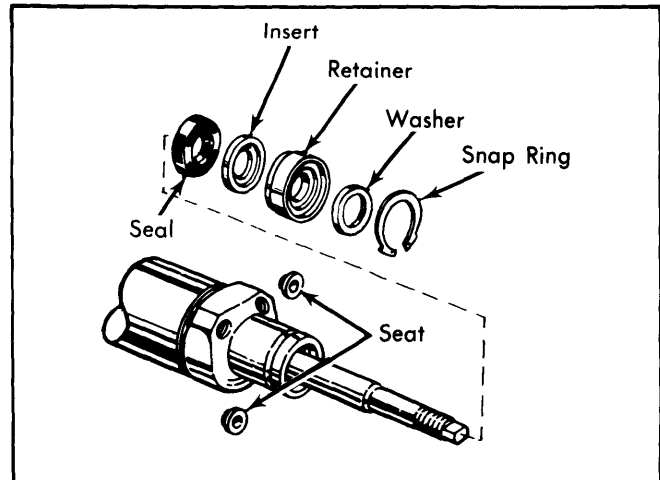

Fig. 1 Disassembled View of Power Cylinder End

CONTROL VALVE

Disassembly — 1) Clamp control valve assembly in a vise with drag link assembly facing up. Straighten three bolt tabs, then remove three bolts attaching drag link assembly. Remove spool bolt nut holding centering spring in position. Remove centering spring, washers and spacer.

2) Carefully lift control valve body over the spool bolt. Remove reaction limit plug from control valve body (drag link end). Remove reaction limit spring, washer and plunger. Now remove reaction limit plug at actuator end of control valve body. **NOTE** — If plug has a press fit, use a $\frac{3}{16}$ " diameter rod approximately four inches long to press plug out as shown in Fig. 2.

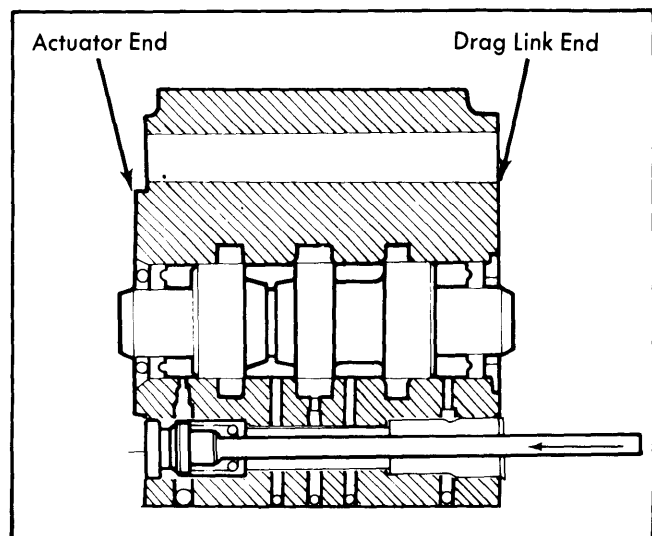

Fig. 2 Pressing Reaction Limit Plug from Control Valve Body

