

# Manual Steering Gears

## SAGINAW RECIRCULATING BALL

Chrysler Corp.  
 Ford Motor Co.  
 General Motors  
 Jeep

### DESCRIPTION & OPERATION

Steering gear is a recirculating ball type and consists of a ball nut connected to steering worm and in mesh with sector gear. Gears are basically the same for all models and service procedures will apply to all gears unless noted otherwise. Precision finished helical grooves within ball nut match helical grooves in worm. Ball bearings roll within grooves when steering wheel is turned. There are two complete circuits using tubular ball guides to deflect balls away from their helical path at one end of groove and guide them back to other end. When steering wheel is turned to right, nut moves upward; when turned to left, nut moves downward. The teeth on sector (forged as part of pitman shaft) and the ball nut are so designed that a tighter fit exists between the two when the front

wheels are straight ahead. Proper engagement between sector and ball nut is obtained by an adjusting screw, which moves pitman shaft endwise, permitting desired engagement of tapered teeth of the ball nut and sector gear. Worm bearing adjuster can be turned to provide proper preloading of the upper and lower bearings.

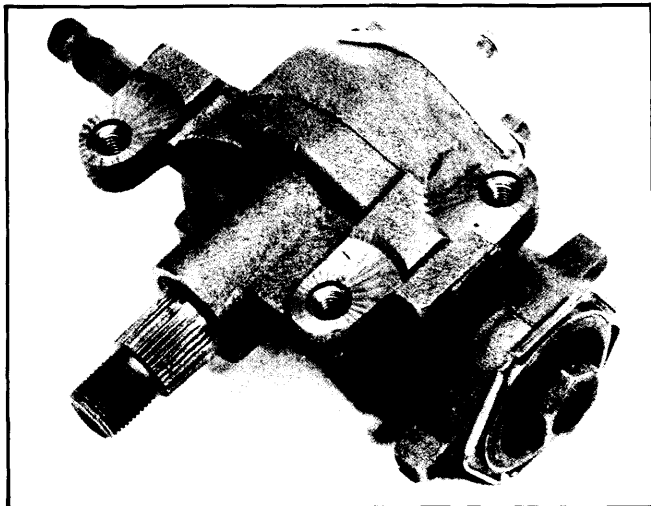

Fig. 1 Horizontal Sector Shaft Model of Saginaw Recirculating Ball Type Steering Gear

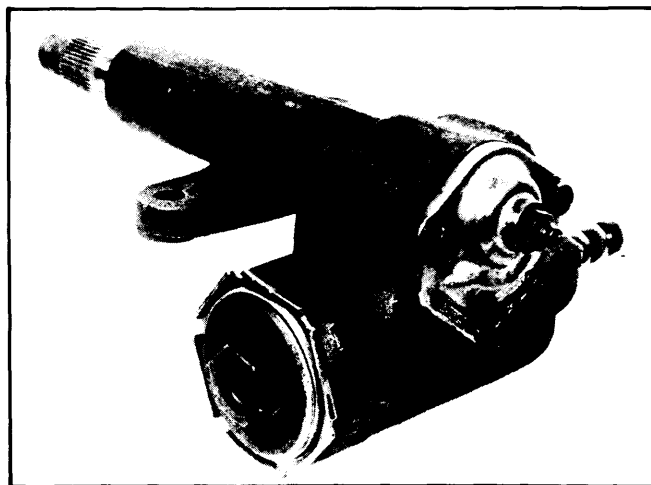

Fig. 2 Vertical Sector Shaft Model of Saginaw Recirculating Ball Type Steering Gear

### LUBRICATION

Periodic lubrication is not necessary. At overhaul, refill gear with lubricant specified in chart.

#### Steering Gear Lubricant

Application	Specified Lubricant
Chrysler Corp. ....	Lithium 12, Hydroxy Stearate E.P. Grease
Ford Motor Co. ....	C3AZ-19578-A
General Motors ....	GM 4673
Jeep .....	Jeep 940657

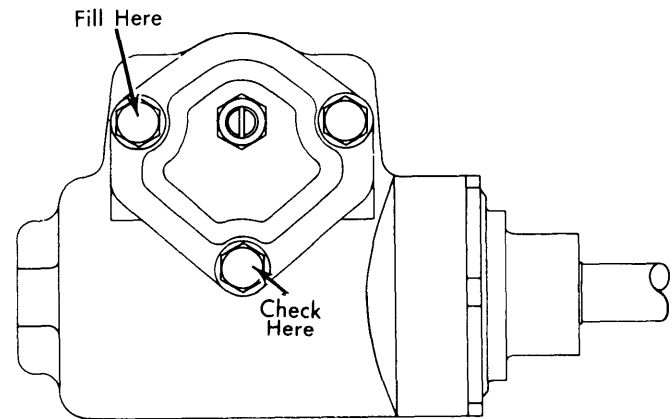

Fig. 3 Lubrication Check and Fill Holes for Gears without a Housing Plug

### ADJUSTMENT

#### PRELIMINARY

Worm bearing preload adjustment must be made first; then, make over-center preload adjustment. Do not reverse the order of adjustment. Adjustment of steering gear can be made on or off vehicle in most cases. When making the Worm Bearing Preload adjustment with gear on vehicle, the pitman arm must be disconnected or the steering linkage disconnected from the pitman arm. The torque wrench can be connected directly to the worm shaft (input shaft) or to the steering wheel retaining nut (steering column drag is negligible). When making the Over-Center Preload adjustment, torque wrench is attached to the sector shaft (after removing pitman arm). If gear is in vehicle, steering column has to be disconnected at flexible coupling between worm shaft and steering shaft.

**NOTE** — On Ford "E" and "F" models, the steering gear must be removed from vehicle to make adjustments.

## SAGINAW RECIRCULATING BALL (Cont.)

### WORM BEARING PRELOAD

Loosen over-center preload adjuster. Tighten worm bearing adjuster until all end play has been removed, then loosen  $\frac{1}{4}$  turn and tighten lock nut. Turn wormshaft carefully to either stop; do not jam into stop as damage to gear could result. Rotate wormshaft back from stop about  $\frac{1}{2}$  turn. Using a INCH lbs. torque wrench, measure the torque required to keep wormshaft in motion about one revolution. Adjust rotating torque to specifications using worm bearing adjuster nut. Tighten lock nut and recheck turning torque; adjust as necessary. Proceed to over-center preload adjustment procedure.

### Worm Bearing Preload

Application	INCH Lbs.
Chrysler Corp.	
All Models Exc. "B" & "PB"	5-8
"B" & "PB" Models	1.5-4.5
Ford Motor Co.	
All Models	3-8
General Motors	
"G" Models	6-11
"C" & "K" Models, P10 & 1500	4-6
Remaining "P" Models	9-12
International Harvester	5-8
Jeep	8

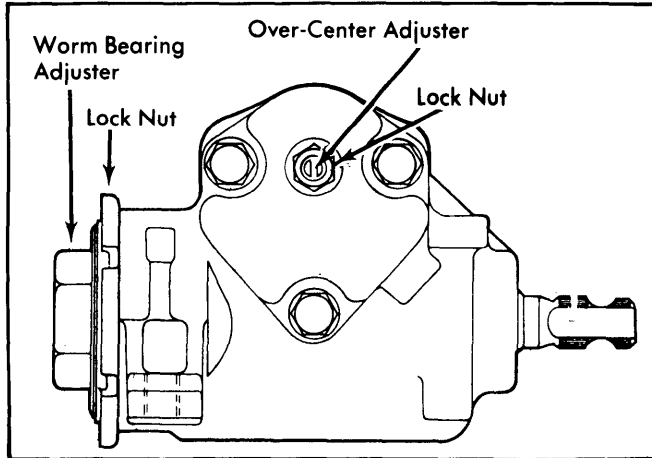

Fig. 4 Adjustment Points for Steering Gear

### OVER-CENTER PRELOAD

1) With worm bearing preload adjusted, turn worm shaft slowly from stop to stop while counting total number of turns. Then, turn shaft half-way back to exact center position. Loosen lock nut and turn over-center adjustment screw in until all lash is taken out of shaft. Tighten lock nut.

2) Rotate worm shaft slightly off center ( $45-90^\circ$ ), then attach an INCH lbs. torque wrench to worm shaft. Using torque wrench as a lever, rotate worm shaft back through center position and record rotating torque. If rotating torque is not to specifications, repeat procedure. Final rotation of adjustment screw must be clockwise; therefore, if maximum specification was exceeded, screw must be backed out, then rotated in (clockwise) to approximate new setting.

### Over-Center Adjustment

Application	Over-Center Preload <sup>①</sup>	Maximum Total
Chrysler Corp.		
"B" & "PB" Models	6-7	11.5
All Other Models	5-8	16
Ford Motor Co.		
All Models	3-8	16
General Motors		
"G" Models	5-11	18
"C" & "K" Models, P10 & 1500	4-10	14
P20, 30, 2500, 3500	9-13	25
Jeep	4-10	16

① — Amount in excess of worm bearing preload.

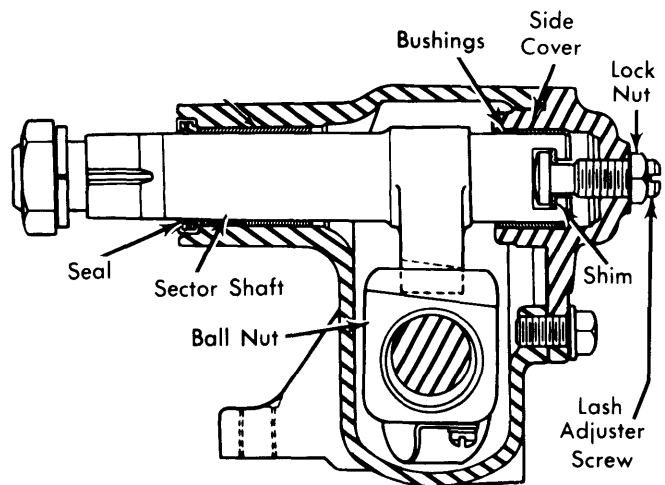

Fig. 5 Cross Section View of Steering Gear

### REMOVAL & INSTALLATION

**NOTE** — All steering component fasteners are made of special quality materials. Replacement fasteners must be of same part number or equivalent. Torque all fasteners and install new cotter pin when used.

### STEERING GEAR

**Chrysler Corp., All Models (Exc. "B" & "PB")** — Remove two bolts from worm shaft-to-steering shaft coupling. Remove pitman arm from sector shaft on steering gear. Remove steering gear-to-frame bolts and remove gear. To install, proceed as follows: Position steering gear to frame and install mounting bolts. Install steering arm, and place wheels in straight-ahead position. Place steering wheel in straight-ahead position. Install worm shaft-to-steering shaft coupling. Tighten all bolts.

**Chrysler Corp., "B" & "PB" Models** — 1) Disconnect battery. Raise vehicle on hoist and disconnect flexible coupling between worm shaft and steering shaft. Disconnect shift linkage at steering column, then remove pitman arm from sector shaft. Remove the three gear mounting bolts. Lower vehicle on hoist and remove toe plate and column support bolts.

## SAGINAW RECIRCULATING BALL (Cont.)

Disconnect wiring and remove column assembly. Raise vehicle on hoist and remove gear through opening on inboard side of frame. If more clearance is needed, remove three bolts from left idler arm bracket and move bracket out of way.

2) To install, proceed as follows: From underside of vehicle, place steering gear into position and install three mounting bolts. Tighten bolts to specifications. If idler arm bracket was removed, reinstall. Install steering arm on sector shaft. Install washer and retaining nut, then tighten to specifications. Install steering column assembly and connect column wiring. Install shift linkage at steering column. Connect steering shaft coupling at worm shaft and reconnect battery.

**Ford Motor Co., "F" Models** — 1) Disconnect worm shaft from steering shaft. Disconnect brake line bracket. Raise front of vehicle and install safety stands. Disconnect pitman arm from sector shaft using suitable tool (T64P-3590-F). Remove steering gear housing attaching bolts, then remove gear.

2) To install, proceed as follows: With steering wheel spokes aligned, front wheels in straight-ahead position, and sector shaft in centered position, install steering gear. Tighten bolts to specification. Reinstall brake line bracket to steering gear cover studs. Install pitman arm to sector shaft and tighten nut. Connect worm shaft to steering shaft.

**Ford Motor Co. "E" Models** — 1) Raise vehicle on hoist, then disconnect wormshaft from steering shaft. Disconnect drag link from pitman arm. Remove pitman arm attaching nut, and separate pitman arm from sector shaft using a puller. While supporting steering gear, remove bolts attaching steering gear to frame side rail. Lower steering gear assembly from vehicle.

2) To install, center wormshaft of steering gear and install gear onto frame side rail and tighten bolts. Connect pitman arm to sector shaft and drag link to pitman arm. Tighten nuts and install cotter pins. Attach flex coupling to steering shaft flange.

**General Motors, All Models** — 1) Set front wheels in straight-ahead position. Remove flexible coupling-to-steering shaft flange bolts or lower universal joint pinch bolt. Mark position of universal yoke-to-worm shaft. Mark relationship of pitman arm-to-sector shaft. Remove pitman arm using suitable puller (J-6632). Remove steering gear mounting bolts and remove gear assembly. To install steering gear on "C", "G" and "K" models, go to step 2); to install gear on "P" models, go to step 3).

2) Install flexible coupling on worm shaft aligning flat on coupling with flat on shaft. Push coupling on shaft until shaft hits shoulder and install pinch bolt. **NOTE** — Pinch bolt must pass through shaft undercut. Place gear in position guiding coupling bolt into steering shaft flange. Install gear-to-frame bolts and torque to specification. If flexible coupling alignment pin plastic spacers are used, make sure they are bottomed on pins, tighten flange bolt nuts and remove plastic spacers.

**NOTE** — Plastic spacers must be removed before driving vehicle. Purpose of plastic spacers are to aid in centering pins in flange openings and also maintain correct coupling-to-flange dimension. Check that flexible coupling-to-steering shaft flange dimension is .250-.375". If flexible coupling alignment pin plastic spacers are not used, center pins in slots in steering shaft flange and then install and tighten flange bolt nuts.

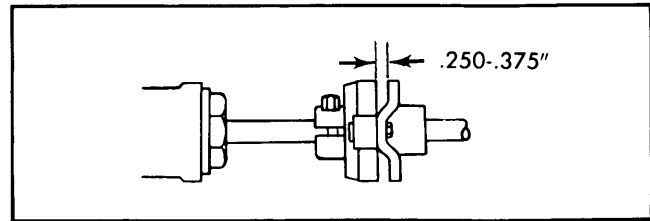

Fig. 6 Adjusting Flexible Coupling for All General Motors Models

3) With "P" models, place steering gear in position guiding worm shaft into universal joint assembly lining up marks made during removal. **NOTE** — If a new gear is installed, line up mark on worm shaft with slit in universal joint yoke. Install gear mounting bolts and torque to specification. Install universal joint pinch bolt, bolt must pass through shaft undercut. Install pitman arm lining up marks and tighten shaft nut or pinch bolt.

**Jeep, All Models** — 1) Remove intermediate shaft to worm shaft coupling clamp bolt and disconnect intermediate shaft. Remove pitman arm nut and washer. Pull pitman arm off shaft using a suitable puller (J-6632).

2) On Wagoneer, Cherokee and Truck models, remove steering gear to frame rail bolts and remove steering gear from vehicle. On CJ models, raise left side of vehicle slightly to release tension from left front spring. Place safety stand under frame.

3) Remove bolts securing steering gear lower bracket to frame. Remove bolts securing steering gear upper bracket to crossmember. Remove steering gear from vehicle. Remove brackets if necessary. To install, reverse removal procedure.

## SECTOR SHAFT SEAL

**NOTE** — For models not listed, seal replacement procedure was not available from manufacturer at time of publication.

**Chrysler Corp., "B" & "PB" Models** — 1) Sector shaft seal can be replaced without removing steering gear from vehicle using following procedure: Remove pitman arm using suitable puller (C-1450). Use suitable tool set (C-3880) to service sector shaft seal. Tool set consists of adapter (SP-3056), half rings (SP-1932), and nut (SP-3610).

2) Slide threaded adapter over end of sector shaft and install nut portion of a suitable tool. (See Fig. 7) Apply pressure on adapter with nut while screwing adapter into seal until it grips seal firmly. Place two half rings and retainer over both portions of tool. Turn nut counterclockwise to withdraw seal from housing.

3) To install seal, place seal on shaft with seal lip facing gear housing. Place installing adapter against seal. Press seal in until a gap of 1/4" exists between adapter and housing. Place nut from tool set on sector shaft and turn it down against adapter, pressing seal into housing until step on adapter contacts end of housing. Remove tool, install pitman arm and tighten nut to specifications.

## SAGINAW RECIRCULATING BALL (Cont.)

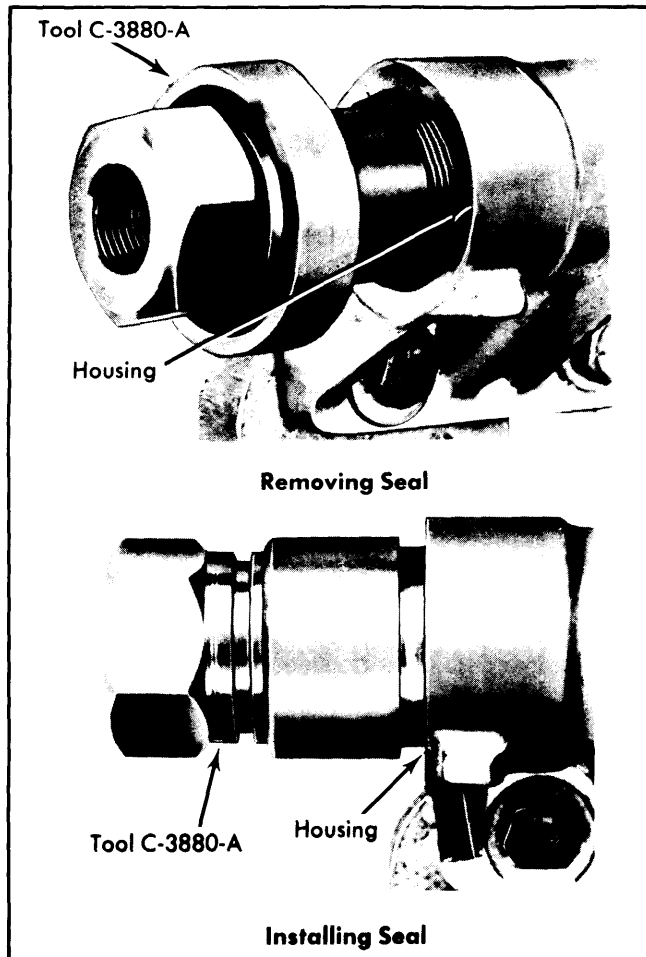

Fig. 7 Replacing the Sector Shaft Seal on Chrysler "B" and "PB" Models

**General Motors (All Models) – 1)** On "K" models, steering gear must be removed to replace seal; on all other models, gear can remain in vehicle. Rotate steering wheel (or worm shaft) from stop to stop while counting number of turns. Now turn wheel (or worm shaft) back half way, placing gear at center of travel. Loosen lash adjuster lock nut and turn lash adjuster a few turns counterclockwise.

**2)** Remove bolts attaching side cover to housing, and lift sector shaft and side cover assembly from housing. Pry sector shaft seal from housing using a screwdriver being careful not to scratch housing bore. Inspect gear lubricant for contamination, if lubricant is contaminated in any way, gear should be completely overhauled.

**3)** Lubricate new sector shaft seal with suitable steering gear lubricant (GM 4673M). Position seal in sector shaft bore and tap into place using a suitable socket. Remove lash adjuster lock nut, and side cover from sector shaft assembly by turning lash adjuster screw clockwise. Install sector shaft in gear so center tooth of sector enters center tooth space of ball nut. Fill gear housing with lubricant and install a new side cover gasket on gear housing. Install side cover over sector shaft by reaching through cover hole with a screwdriver and turning lash adjuster screw counterclockwise until screw bottoms, then back off screw one-half turn. Install side cover bolts and

tighten to specification. Install lash adjuster lock nut and perform steering gear adjustments.

## OVERHAUL

**NOTE** – Overhaul procedures sometimes vary between vertical and horizontal sector shaft steering gears. These differences are noted in text. To identify the two different gears, see Fig. 1 and Fig. 2 at the beginning of this article.

## DISASSEMBLY

**All Models – 1)** Place steering gear in a vise clamping onto one mounting tab or suitable fixture. Worm shaft should be in a horizontal position. Loosen sector shaft lock nut and turn lash adjuster a few turns out. Loosen lock nut on worm shaft adjuster and turn adjuster out a few turns. Rotate worm shaft from stop to stop while counting number of turns. Then, turn shaft back one-half number of turns to center sector shaft. Place a pan under assembly to catch oil and remove three self-locking bolts holding side cover to housing.

**2)** Tap on end of sector shaft with a mallet and lift side cover and sector shaft assembly from gear housing. If sector does not clear opening easily, turn worm shaft by hand until sector can be removed. Remove worm shaft adjuster and lock nut assembly with lower worm shaft bearing (upper worm shaft bearing on vertical sector shaft models). Remove worm shaft and ball nut assembly from housing while housing is in a horizontal position to prevent ball nut from running down worm shaft. If ball nut does run down worm shaft with any speed, damage to ball guides will result when nut hits stop. Remove upper bearing from worm guide (lower bearing from inside gear housing on vertical sector shaft models).

**3)** On horizontal sector shaft models only, use a screwdriver to pry lower bearing retainer from worm adjuster assembly; then, remove bearing. On all models, Remove lock nut from lash adjuster screw in side cover. Remove lash adjuster screw. Slide screw and shim out slot in end of sector shaft. Pry out and discard both sector shaft and worm shaft seals.

## CLEANING & INSPECTION

Wash parts with clean solvent and blow dry with air. Inspect bearings and races for signs or wear. Any parts that show signs of wear should be replaced. Inspect sector shaft fit at side cover bushing. If bushing is worn, a new side cover and bushing assembly should be installed. Check ball nut and worm shaft assembly for wear and straightness.

## COMPONENT SERVICE

**Sector Shaft & Worm Shaft Seals** – Pry out seals using a suitable screwdriver (if not previously removed). Before installing new seals, check condition of sector shaft bushings and upper worm shaft bearing race. Use a suitable size socket pressing on outer diameter of seal to replace seal. Avoid installing in a cocked position.

**Sector Shaft Bushing(s)** – Support steering gear in a suitable arbor press and drive sector shaft bushing(s) from housing. Press new bushing(s) into position reversing removal procedure. Replacement bushings are diamond bored to size and need no reaming.

# Manual Steering Gears

## SAGINAW RECIRCULATING BALL (Cont.)

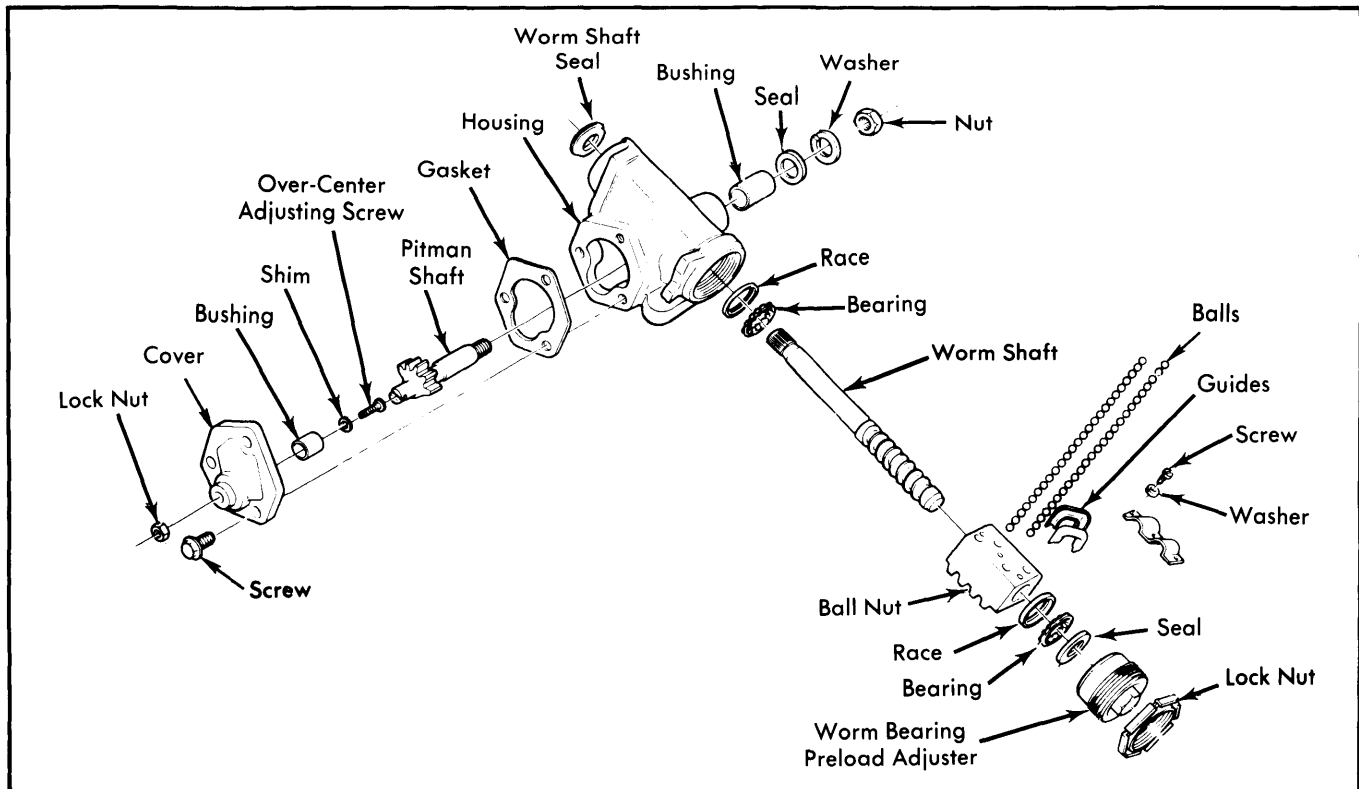

Fig. 8 Exploded View of Recirculating Ball Steering Gear (General Motors Model Shown)

**Worm Shaft Bearing Race (In Adjuster)** – On gears with horizontal sector shaft, remove worm shaft bearing race using a suitable puller and slide hammer. On vehicles with vertical sector shaft, remove worm shaft bearing race using a hammer and punch. On either type gear, press bearing in place using a suitable tool (J-5755).

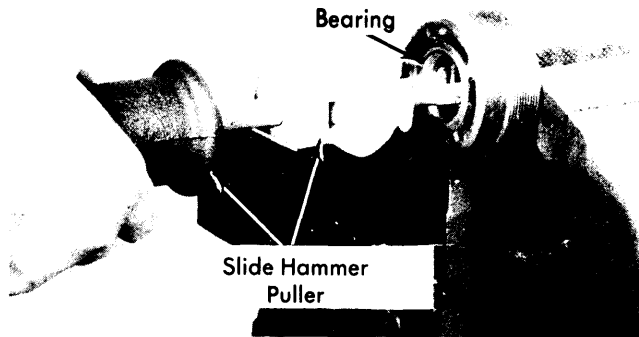

Fig. 9 Removing Wormshaft Bearing Race on Horizontal Sector Shaft Gear

**Worm Shaft Bearing Race (In Housing)** – On vertical sector shaft gears, drive out sheet metal expansion plug using a drift or punch. On all types, drive out housing bearing race with a punch and press new race in with suitable tool (J-5755). On vertical shaft models, install a new expansion plug and press on center of plug to deform it inwards, locking it into place.

**Ball Nut & Wormshaft Assembly** – Ball nut disassembly is not necessary unless there is indication of binding or tightness when rotating worm. **NOTE** – For Chrysler Corp. "B" and "PB" models, disassembly is not recommended. Replace ball nut and wormshaft as an assembly. If disassembly is required, proceed as follows:

1) This first step is going to let loose about 50 ball bearings; be ready to catch them ALL. Remove clamp that retains ball guides and pull guides from ball nut while catching balls in clean pan. Turn nut over and rotate worm until all balls have fallen into pan. Remove worm from ball nut. Wash parts and inspect worm, nut grooves, and ball bearings for indentations. Check ball guides for damage at ends where they deflect or pick up balls from helical path on worm.

2) To reassemble ball nut and worm shaft, insert ball nut over worm so that the shallow end of the ball nut teeth are on left side when looking from steering wheel end of worm shaft. Align grooves in worm and nut by sighting through ball guide holes. There are two types of ball guides: ones with holes in middle, and ones with no hole. If ball guides have hole in middle, insert ball guides into holes in ball nut. Divide balls into

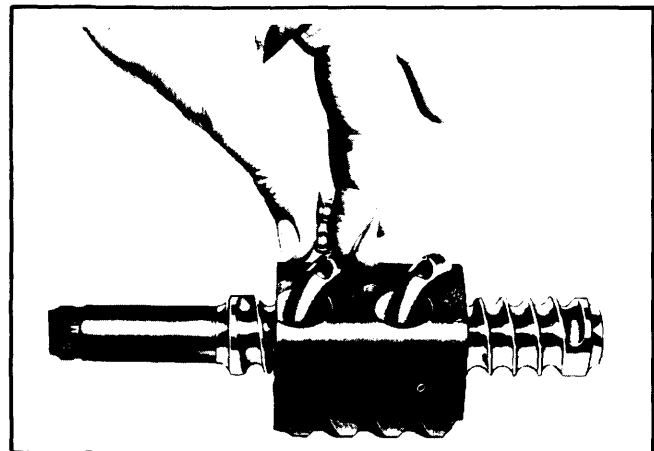

Fig. 10 Filling Ball Circuits Through Holes in Ball Guides

## SAGINAW RECIRCULATING BALL (Cont.)

two equal groups and insert each group into a ball guide while slowly turning worm shaft. If guides have no hole, separate the halves and fill one-half of each set with balls. Cover filled half with other half and plug ends with lubricant so that balls do not fall out. Fill each circuit in ball nut with half of remaining balls in one circuit, and half in the other while slowly turning worm shaft. Insert ball guides. On both types, install ball guide retainer.

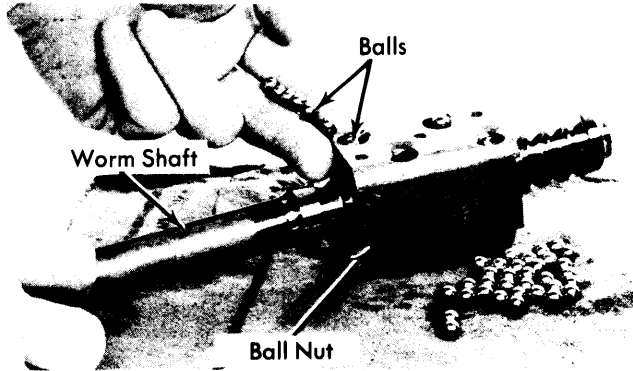

Fig. 11 Filling Ball Circuits Through Holes in Ball Nut

### REASSEMBLY

**All Models** - 1) Place gear housing in a vise with worm shaft bore horizontal and side cover opening facing up. With sector shaft and worm shaft seals, sector shaft bushings, and worm shaft bearing races installed, and ball nut assembly together, proceed as follows: On all vertical sector shaft gears, proceed to step 2). On horizontal sector shaft gears, slip upper ball bearing over worm shaft and insert worm and nut assembly into housing feeding end of shaft through upper ball bearing race and seal. Place ball bearing in adjuster race and press stamped retainer into place with suitable socket. Install adjuster and lock nut into housing carefully guiding worm shaft into bearing until nearly all end play is removed from worm shaft.

2) On vertical sector shaft gears, place worm shaft bearing in housing race. Slide other bearing and adjuster plug assembly over upper end of worm shaft. Insert worm shaft, nut and adjuster assembly into housing while guiding lower end of worm into housing bearing. Thread adjuster into housing until nearly all end play is removed from worm shaft.

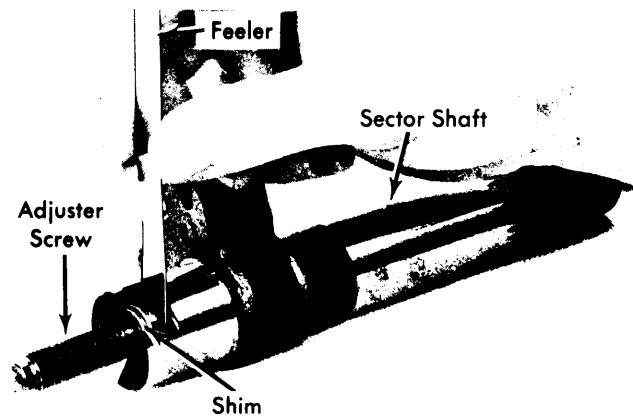

Fig. 12 Checking Lash Adjuster Clearance

3) With all models, position lash adjuster (with shim) in slotted end of sector shaft. Check end clearance which should not be more than .002" (see Fig. 12). If clearance is greater than .002", a steering gear lash adjuster shim kit is available.

Lubricate gear as follows: Rotate worm until ball nut is at end of travel while forcing as much grease as possible into housing without losing it out sector shaft opening. Rotate worm until ball is at other end and apply more lubricant.

4) Rotate worm until ball nut is in center of worm; this will help sector and ball nut engage properly. Insert sector shaft and lash adjuster screw (without side cover) into housing so center tooth of sector enters center tooth space in ball nut. Apply more lubricant into housing. Install side cover gasket. Install side cover over sector shaft by reaching through cover with a screwdriver and turning lash adjuster screw counterclockwise until screw bottoms; then, back screw off one-half turn. Loosely install a new lock nut onto adjuster screw. Install and tighten side cover bolts to specifications. **NOTE** - If new side cover bolts are used, they must be specified, self-locking bolts. Adjust worm bearing preload and over-center preload as previously outlined in Adjustments.

### TIGHTENING SPECIFICATIONS

Application	Ft. Lbs.
Worm Bearing Preload Adj. Lock Nut	
Ford "F" Models	60-80
Jeep	70-110
All Other Models	85
Over-Center Preload Adj. Lock Nut	
Chrysler "B" & "PB" Models	35
Ford "F" Models	32-40
Jeep	18-27
All Other Models	25
Side Cover Bolts	
Chrysler "B" & "PB" Models	25
Ford "F" Models	17-25
Jeep	23-30
All Other Models	30
Flexible Coupling Bolts	
Jeep	25-35
General Motors	20
All Other Models	30
Pitman Arm-to-Sector Shaft	
Chrysler "B" & "PB" Models	175
Chrysler (Except "B" & "PB")	185
Ford "E" & "F" Models	170-230
General Motors "K" Models	90
General Motors (Except "K")	185
Jeep	160-210
Steering Gear-to-Frame	
Ford Motor Co. & Jeep	65
Chrysler Corp.	
"B" & "PB" Models	100
"AD", "AW", "PD" & "PW" Models	70
"D" & "W" Models	
3/16-20	55
1/2-20	85
General Motors	
"G" Models	110
All Others	65
Steering Gear Bracket-to-Frame (Jeep Only)	
"CJ" Models	
3/8-16	40
3/16-20	65
All Others	65
Steering Gear Support Reinforcement	
General Motors "P" Models Only	30