

Front Suspension

FORD MOTOR CO. 4-WD COIL SPRING TYPE

F-150
U-100 (Bronco)

REMOVAL & INSTALLATION

DESCRIPTION

Front suspension consists of a driving axle, two coil springs, two radius arms, two hydraulic shock absorbers, and a side strut bar. Radius arms attach to frame side rails and are clamped around axle housing. Coil springs are mounted to radius arms, directly above axle housing, and to brackets attached to frame side rails. Shock absorbers attach to frame side rails and radius arms, behind springs. Side strut bar, used to eliminate axle side movement, is attached to left frame rail, and right side of axle housing.

ADJUSTMENT

WHEEL ALIGNMENT SPECIFICATIONS & PROCEDURES

See *Wheel Alignment Specifications & Procedures* in **WHEEL ALIGNMENT** Section.

WHEEL BEARING ADJUSTMENT

See *Wheel Bearing Adjustment* in **WHEEL ALIGNMENT** Section.

COIL SPRING

Removal — Raise vehicle and place on safety stands. Raise weight of front axle with jack. Remove lower shock absorber bracket bolt. Remove lower and upper spring retainer bolts. Lower axle with jack to relieve spring tension. Remove spring and lower retainer.

Installation — To install, reverse removal procedure. Tighten nuts and bolts to specifications.

RADIUS ARM

Removal — Raise and support vehicle under frame. Disconnect shock absorber from radius arm, and pull out of the way. Remove lower spring retainer attaching bolts, and remove cotter pin and nut attaching radius arm to frame. Remove radius arm-to-radius arm cap attaching bolts, and remove cap. Move axle housing slightly forward and remove radius arm from vehicle.

NOTE — Radius arm and radius arm caps are a matched set. They are identified by a letter "T" with a number (1 through 100). If there is no "T" identification on either arm or cap, it should not be installed on F-150 models.

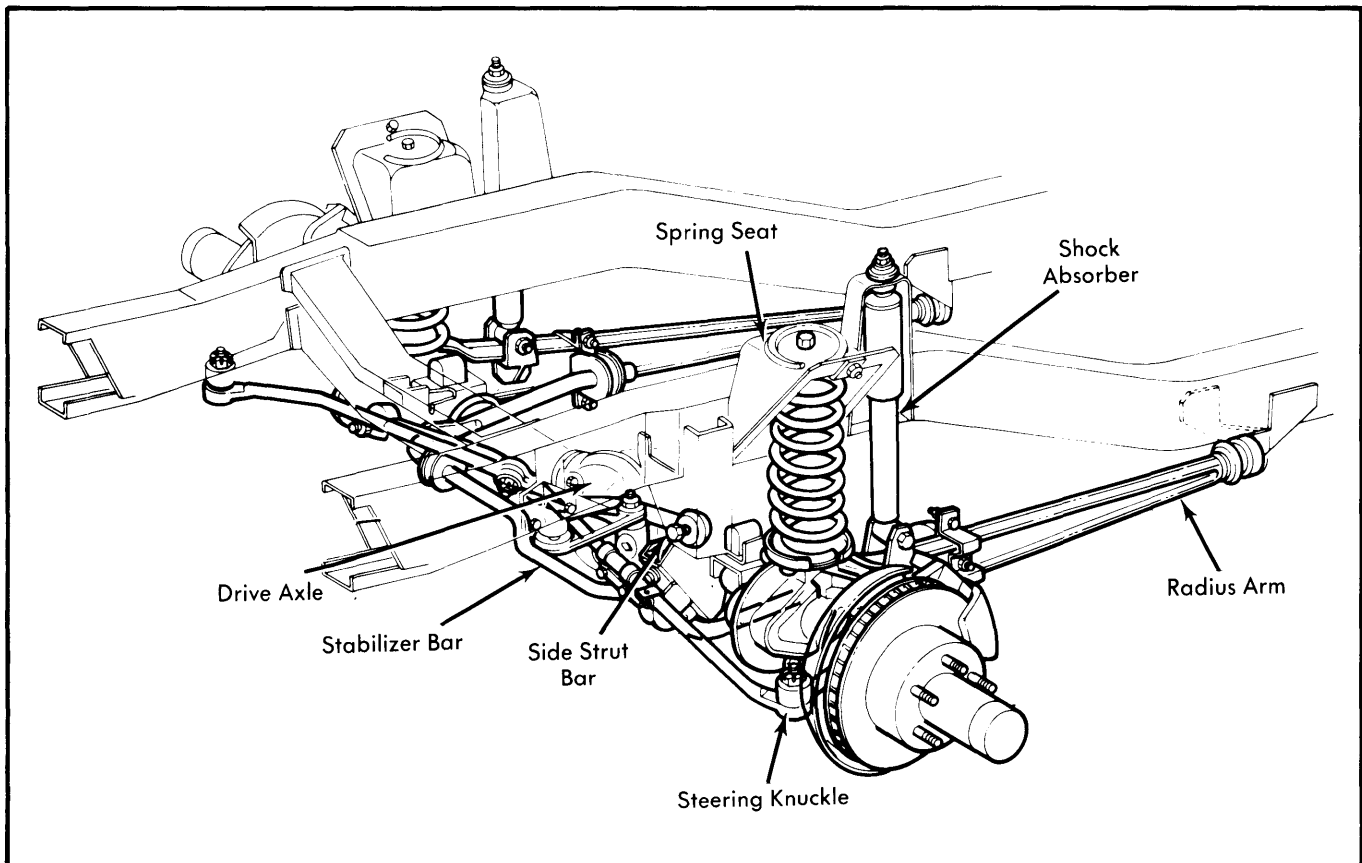

Fig. 1 U-100 (Bronco) Front Suspension Assembly
F-150 Similar

FORD MOTOR CO. 4-WD COIL SPRING TYPE (Cont.)

Installation — Position rear of radius arm in bracket on frame, and loosely install nut. Position front of radius arm on axle housing, and install radius arm cap with numbers on cap and radius arm together. Install cap attaching bolts, and tighten diagonally in pairs. Position spring and lower spring retainer on radius arm and loosely install bolts. Connect shock absorber to radius arm, and tighten all nuts and bolts.

STEERING KNUCKLE

Removal & Installation — See *Open Steering Knuckle* article in *DRIVE AXLE* Section for steering knuckle removal and installation.

TIGHTENING SPECIFICATIONS

Application	Ft. Lbs.
Upper Spring Retainer	20-25
Lower Spring Retainer	45-55
Side Strut Bar-to-Frame	110-130
Side Strut Bar-to-Axle	115-205
Radius Arm-to-Bracket	80-120
Radius Arm Cap-to-Radius Arm	90-110
Shock Absorber Mounting Bolt	
Lower	40-60
Upper (F-100)	40-60
Upper (U-100)	15-25