

## REAR WHEEL BEARING ADJUSTMENT

### ADJUSTMENT

#### DODGE

**200 & 300 Series, & All "M" Models** — Tighten inner adjusting nut while rotating brake drum until a slight drag is felt. Now back off adjusting nut  $\frac{1}{6}$  turn to permit a free rotation with zero to a slight amount of end play. Install nut lock and lock nut. Tighten lock nut to 35-65 ft. lbs. **NOTE** — Make sure adjusting nut does not turn while tightening lock nut. Bend one lock tab over adjusting nut and other tab over lock nut.

#### CHEVROLET

**9 $\frac{3}{4}$ " & 10 $\frac{1}{2}$ " Ring Gear Models** — Tighten bearing adjusting nut to 50 ft. lbs. while rotating brake drum. Back off nut slightly and retighten to 35 ft. lbs. while rotating brake drum. Now back off nut  $\frac{1}{4}$  turn. Install nut retainer so that tang will engage nearest slot on adjusting nut. Install outer lock nut and tighten to 65 ft. lbs. There should be .001-.010" bearing end play.

**12 $\frac{1}{4}$ " Ring Gear Models** — Tighten bearing adjusting nut to 90 ft. lbs. while rotating brake drum. Back off nut  $\frac{1}{8}$  turn. Install nut retainer so that retainer tang will engage nearest slot on adjusting nut. Install outer lock nut and tighten to 250 ft. lbs. There should be no bearing end play. Bearing should be slightly preloaded.

#### FORD MOTOR CO.

**F250 (2 & 4WD) & F350** — Tighten adjusting nut to 50-80 ft. lbs. while rotating brake drum. Now back off adjusting nut  $\frac{3}{8}$  turn. Coat a new lock washer with axle lubricant and install against adjusting nut with smooth side out. Install lock nut and tighten to 90-110 ft. lbs. Wheel should rotate freely with .001-.010" bearing end play.

**E250 & E350** — Tighten adjusting nut to 120-140 ft. lbs. while rotating brake drum. Back off adjusting nut to obtain .001-.010" end play. This should require backing off nut  $\frac{1}{8}$ - $\frac{1}{4}$  turn. Install locking wedge in key slot. Seat wedge using a suitable tool (T57T-1170-A) and hammer. Make sure locking wedge does not bottom against shoulder of adjusting nut. **NOTE** — The locking wedge and adjusting nut can be reused, providing that the locking wedge cuts a new groove into nylon retainer ring. If it is not possible to obtain the correct end play and install the wedge in uncut nylon, replace locking wedge and adjusting nut.

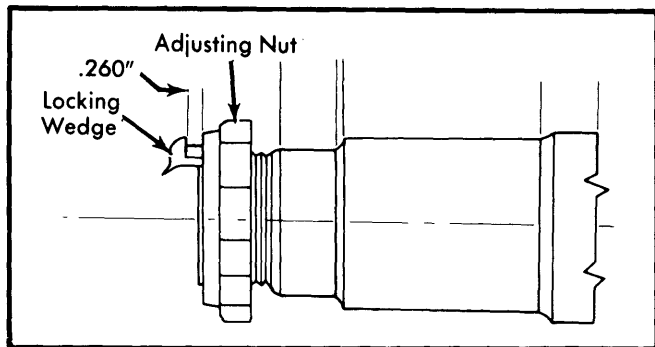

Fig. 1 Installing Locking Wedge  
Ford E250 and E350 Models

**"M" Models** — Tighten adjusting nut to 140 ft. lbs. while rotating brake drum. Now back off nut  $\frac{1}{2}$  turn then retighten to 50 ft. lbs. while rotating brake drum. Again back off adjusting nut  $\frac{1}{3}$  turn. Install lock washer. If necessary, back off adjusting nut slightly to allow lock washer hole to align with dowel pin. Install lock nut and tighten to 150 ft. lbs. Wheel must rotate freely with .001-.010" end play. There should be no bearing preload.

#### GMC

**9 $\frac{3}{4}$ " & 10 $\frac{1}{2}$ " Ring Gear Models** — Tighten bearing adjusting nut to 50 ft. lbs. while rotating brake drum. Back off nut slightly and retighten to 35 ft. lbs. while rotating brake drum. Now back off nut  $\frac{1}{4}$  turn. Install nut retainer so that retainer tang will engage nearest slot on adjusting nut. Install outer lock nut and tighten to 65 ft. lbs. There should be .001-.010" bearing end play.

**12 $\frac{1}{4}$ " Ring Gear Models** — Tighten bearing adjusting nut to 90 ft. lbs. while rotating brake drum. Back off nut  $\frac{1}{8}$  turn. Install nut retainer so that retainer tang will engage nearest slot on adjusting nut. Install outer lock nut and tighten to 250 ft. lbs. There should be no bearing end play. Bearing should be slightly preloaded.

**FWD Motor Home** — Tighten adjusting nut to 25-30 ft. lbs. while rotating brake drum. Now back off nut  $\frac{1}{2}$  turn (maximum) and install lock washer. Install lock nut and tighten to 50 ft. lbs. Wheel should rotate freely with .001-.010" end play.

#### INTERNATIONAL HARVESTER

**MS1210, 1310MHC & 1510MHC** — Tighten inner adjusting nut to 50 ft. lbs. while rotating brake drum. Now back off adjusting nut  $\frac{1}{4}$  turn. Install lock washer and outer lock nut. Tighten lock nut to 150 ft. lbs. Bend one tang of lock washer over adjusting nut and other tang over lock nut.

#### JEEP

**Truck Models (W/Dana/Spicer 60 Axle)** — Tighten adjusting nut to 50 ft. lbs. while rotating brake drum. Back off adjusting nut  $\frac{1}{6}$  turn. Brake drum should rotate freely without any lateral movement. Install lock washer and lock nut. Tighten lock nut to 50 ft. lbs. Bend lock washer lip over lock nut.

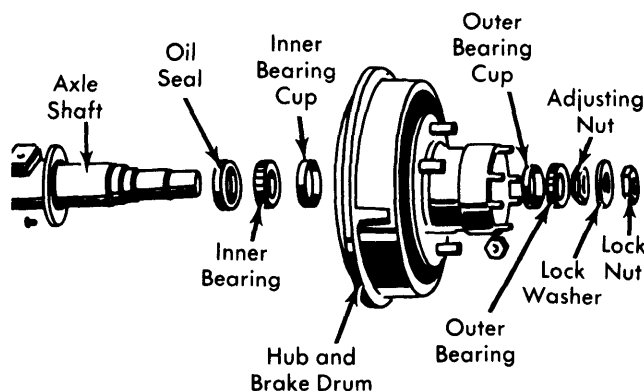

Fig. 2 Typical Full-Floating Rear Wheel Bearing