

Wheel Bearing Adjustment

FRONT WHEEL BEARING ADJUSTMENT

ADJUSTMENT

NOTE — For removal and installation of front wheel bearings, see the Dana/Spicer Full Floating Axle article in DRIVE AXLE Section.

NOTE — Correct wheel bearing adjustment is very important on vehicles with disc brakes, as too much end play in bearings will cause disc wobble and brake damage.

NOTE — On all vehicles with disc brakes, caliper assembly must be removed before disc and hub, in order to work on wheel bearings. Caliper-to-disc clearance is very critical on these vehicles. It is not necessary to disconnect brake hoses in order to remove caliper assembly. Wire caliper out of the way (do not hang on brake hose).

NOTE — To seat bearings properly, hub must be turning while tightening adjusting nut. If cotter pin holes do not line up, back off nut only enough to insert cotter pin.

CHRYSLER CORP.

"AD", "B", "D", "PB" & "PD" Models — Tighten wheel bearing adjusting nut to 360-480 INCH Lbs. Back off nut to release preload and retighten finger tight. Install lock nut and cotter pin. Check that final end play is .001-.003".

W100, W200, "AW" & "PW" Models — Not a bearing adjustment. When installing hub assembly, tighten nut to 100 ft. lbs. Tighten nut to next slot if necessary, to install cotter pin.

W200 (W/Extra Equip.) & W300 — Tighten inner lock nut to 50 ft. lbs. Back nut off and retighten to 30-40 ft. lbs. Back nut off 135-150°, then assemble lock ring and outer lock nut. Tighten lock nut to 65 ft. lbs. Bend tangs over inner and outer locking nuts. Final end play should be .001-.010".

"M" Models — Tighten adjusting nut to 50 ft. lbs. Back nut off 1/6 to 1/4 of a turn and install cotter pin. **CAUTION** — Do not back off less than 1/6 of a turn. Nut should not be more than finger tight.

FORD MOTOR CO.

"U" Models (Bronco) & F150 & 250 4WD — Tighten adjusting nut to 50 ft. lbs while rotating rotor. Back nut off 1/4 turn. Install locking nut and tighten to 50-70 ft. lbs. Final end play should be .001-.010".

"E" & "F" 2WD Models — Tighten adjusting nut to 22-25 ft. lbs while rotating rotor. Now back off adjusting nut 1/4 turn. Install retainer and cotter pin without backing off nut any more.

"M" Models — Tighten adjusting nut to 70-100 ft. lbs. Back off adjusting nut 1/2 of a turn. Tighten adjusting nut finger tight (13-17 INCH lbs.) while moving top of tire in and out. Install cotter pin. Final end play should be .001-.010".

GENERAL MOTORS

GMC Motor Home (Front Wheels) — Not a bearing adjustment. When installing hub assembly, tighten nut to 100

ft. lbs. Tighten nut to next slot if necessary to install cotter pin.

CAUTION — Do not allow torque to exceed 280 ft. lbs.

K10, K1500, K20 & K2500 — Tighten inner adjusting nut to 50 ft. lbs. while rotating rotor. Now back off nut and retighten to 35 ft. lbs. while rotating rotor. Again back off nut 3/8 turn. Install inner nut lock by aligning nearest hole in lock with adjusting nut pin. Install outer lock nut and tighten to 50 ft. lbs.

K30 & K3500 — Tighten inner adjusting nut to 50 ft. lbs. while rotating rotor. Now back off nut and retighten to 35 ft. lbs. while rotating rotor. Again back off nut 3/8 turn. Install lock washer and outer lock nut. Tighten lock nut to 65 ft. lbs. Bend ear of lock washer over outer nut at a minimum of 60°.

"C", "G" & "P" Models — Tighten adjusting nut to 12 ft. lbs. Back off adjusting nut and retighten finger tight. Loosen nut to line up for cotter pin installation but to not loosen more than 1/2 of a flat. Install cotter pin and check that final end play is .001-.005".

INTERNATIONAL HARVESTER

All Models — Tighten adjusting nut to 30 ft. lbs. Back off adjusting nut 1/4 of a turn and retighten nut finger tight. Back nut off slightly and install cotter pin. Install and tighten lock nut. Check that final end play is .001-.010".

JEEP

"CJ" Models — Install inner lock washer and adjusting nut. Tighten nut to 50 ft. lbs. while rotating rotor. Now back off nut 1/3 turn. Install outer lock washer and nut. Tighten nut to 50 ft. lbs. Bend lock washer lip over nut.

Remaining Models — Install inner adjusting nut. **NOTE** — Make sure pin on nut faces away from bearing. Tighten adjusting nut to 50 ft. lbs. while rotating rotor. Now back off nut 1/3 turn. Install inner nut lock washer by aligning nearest hole in lock washer with adjusting nut pin. Install outer lock nut and tighten to 50 ft. lbs.

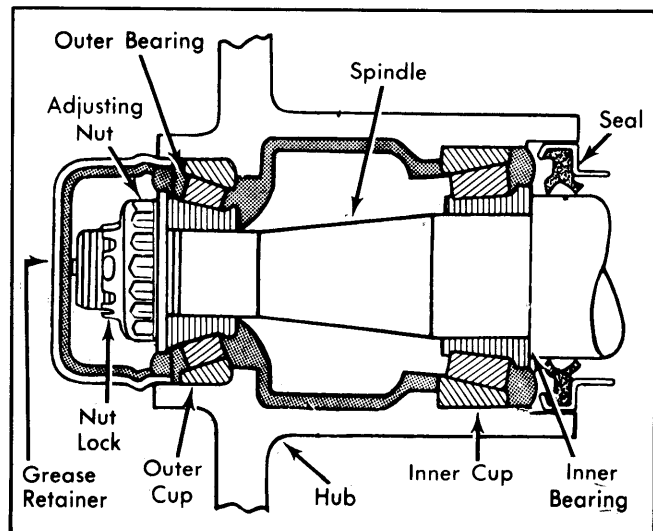

Fig. 1 Typical Front Wheel Bearing Assembly