

## DELCO-MORAINE SINGLE DIAPHRAGM

Chevrolet  
GMC  
Jeep

### DESCRIPTION

A combined vacuum-hydraulic unit which uses a combination of intake manifold vacuum and atmospheric pressure to provide power assist. Reserve vacuum supply and vacuum check valve allow several brake applications, with vacuum assist, after engine has stopped. Unit is composed of two main sections: vacuum power cylinder and dual master cylinder. Vacuum power cylinder contains power piston assembly, which houses control valve, reaction mechanism, and power piston return spring.

### REMOVAL & INSTALLATION

**Removal & Installation** – Remove vacuum line from power unit and hydraulic lines from master cylinder (plug lines). Disconnect stop light switch wires, if necessary. Detach power unit push rod from brake pedal assembly. Unbolt power unit from firewall and remove from vehicle (with master cylinder). To install, reverse removal procedure and bleed system.

### OVERHAUL

**NOTE** – Jeep Corp. does not recommend overhaul of this unit; it is serviced as an assembly.

**Disassembly** – 1) Scribe mark housings (for reassembly), then remove master cylinder. Attach suitable separator tool and wrench (J-9504 and J-22805), press down and turn counterclockwise to separate housings. If necessary, tap lightly with plastic hammer to assist separation. **NOTE** – Do not put pressure on plastic power piston extension. Lift rear housing assembly from unit. Remove clevis, lock nut, silencer retainer, and silencer from push rod. Separate power piston assembly and seal from rear housing.

2) Remove air filter from power piston neck. Pry lock ring off power piston. Remove reaction retainer, piston rod, reaction plate, three reaction levers, air valve springs, small reaction bumper, and air valve spring retainer. Position suitable support plate tool (J-21524) in vise and in notches of support plate. Grip steel plate under diaphragm, press down and turn counterclockwise until plate separates from power piston. Remove air valve snap ring. Using rod (not exceeding 1/2" diameter), press air valve assembly from power piston.

**NOTE** – Air valve (floating control valve) push rod assembly is serviced as complete unit. New assembly should always be installed if original is removed from power piston.

3) Remove power piston return spring from front housing. Remove front housing seal. If defective, remove check valve and grommet. Push master cylinder push rod from center of reaction retainer. Remove "O" ring from master cylinder push rod.

**Cleaning & Inspection** – Clean all metal, plastic, and rubber parts in denatured alcohol. Blow out all passages, orifices, and valve holes with clean, dry air. Air dry all parts. Slight rust on inside of housings can be polished with crocus or emery cloth. There should be no nicks, cuts, or abnormalities of any rubber part. If in doubt about its condition, replace the part.

**Reassembly** – 1) **NOTE** – Lubricate all rubber parts, plastic and metal friction points with suitable lubricant (Delco Silicone Lube #5459912), prior to installation. Replace check valve (with new grommet), if removed during disassembly. Install new front seal. Install new "O" ring in groove on master cylinder piston rod, then insert rod through reaction retainer, with round end at tube end of retainer. Place suitable support plate tool (J-21524) in vise and position power piston on tool. Install new "O" ring on NEW (if removed) air valve assembly, in second groove from push rod forward end. Press NEW air valve assembly, into seat in power piston tube. Install new valve retainer and press into place with suitable tool (J-21601). Install push rod limiter washer over push rod, then install air filter. Press raised flange of power piston diaphragm through center hole of support plate. Hold steel support plate (not diaphragm), place over power piston tube, seating diaphragm flange in groove of tube.

2) Place assembly in padded vise (tube down). DO NOT clamp. Install snap ring in air valve groove. Seat the air valve spring on snap ring and reaction bumper in groove in end of air valve. Position air valve return springs and reaction levers in place. Set reaction plate (numbered side up) on levers and press down until levers pop into place. Assemble master cylinder rod and reaction retainer to power piston. Secure assembly with lock ring on power piston. Install air filter on push rod.

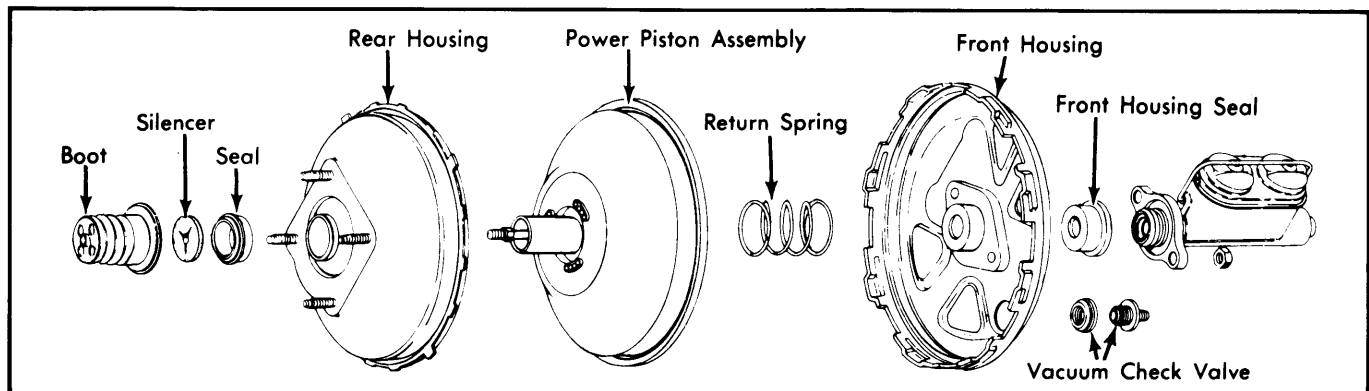

Fig. 1 Exploded View of Delco-Moraine Single Diaphragm Power Unit

# Power Brake Units

## DELCO-MORAINE SINGLE DIAPHRAGM (Cont.)

3) Install new seal in center of rear housing. Assemble power piston to rear housing. Place felt silencer and retainer clip on push rod. Install push rod boot to power piston tube. Assemble lock nut and clevis (if equipped) to push rod. Place front housing assembly on suitable holding fixture (J-22805). Place power piston return spring in front housing. Position rear housing on front housing and lock together. After making sure housings are fully locked together, stake housing in two places approximately 180° apart. Stake housings at tab socket.

### ADJUSTMENT

#### PUSH ROD ADJUSTMENT

**NOTE** — Chevrolet and GMC production push rod is not adjustable. If production rod is reused, gauging is to check proper assembly. If service push rod, which is adjustable, is used to replace production rod, gauging is to set correct rod length.

**Chevrolet & GMC** — Place suitable gauge (J-22647) over piston rod in a position which will allow gauge to be slipped to left or right without contacting studs. Center section of gauge has two levels. Piston rod should always contact longer section (lower level), and never contact shorter section (higher level). Any variation beyond these two limits would require replacement of production piston rod or adjustment of service piston rod.

**Jeep** — Piston rod of replacement units is preset at factory and require no field adjustment.

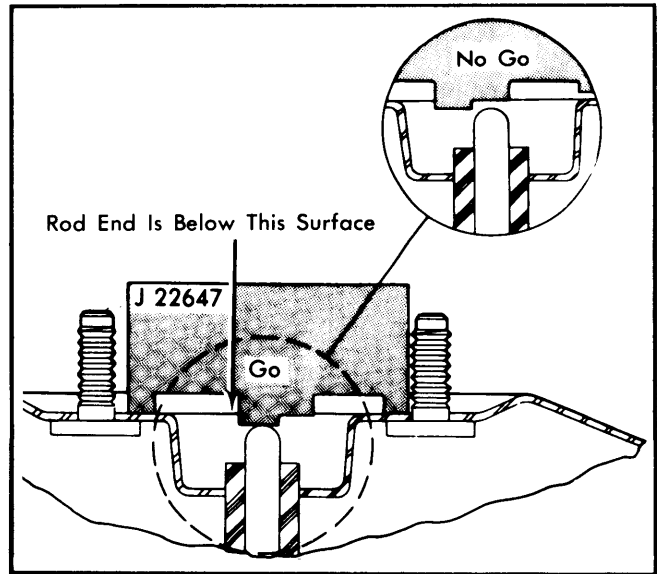

Fig. 2 Checking Piston Rod Height (Nonadjustable Rod Shown)

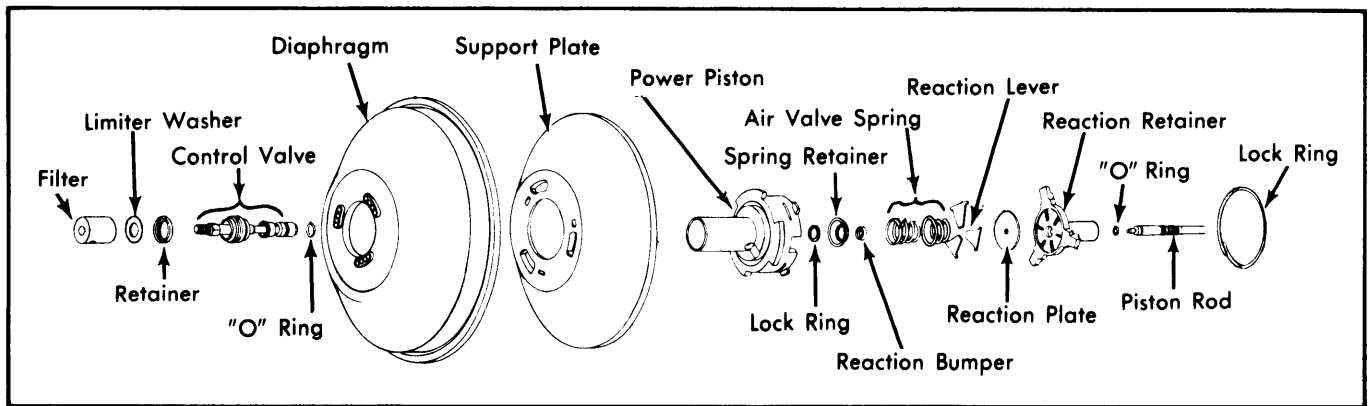

Fig. 3 Exploded View of Power Piston Assembly