

FORD-THOMPSON SLIPPER TYPE

Ford (All Except "E" Models)

DESCRIPTION

Thompson power steering pump is a belt driven, slipper-type assembly with integral reservoir. Pump can be identified by small round filler neck, welded to reservoir. Reservoir is attached to rear of pump housing front plate, and pump body is encased within reservoir. Spring loaded slippers in pump are in constant contact with eccentric, inside diameter of pump housing. As rotor revolves, slippers force fluid from inlet side of pump to flow to control valve. Maximum pressure in system is regulated by pressure relief valve. Valve opens once maximum pressure is reached, thus allowing fluid to flow back into reservoir.

LUBRICATION, TROUBLE SHOOTING & TESTING

See Power Steering General Servicing in this section.

REMOVAL & INSTALLATION

POWER STEERING PUMP

Loosen pivot and adjusting bolts and remove pump drive belt. Disconnect pressure and return hoses (and oil cooler hoses if equipped) from pump and cap ends to prevent loss of fluid. On "F" models, remove pivot bolt and adjustment bolts and withdraw pump from bracket. On "U" models, remove bolts attaching adjustment bracket to water pump, hold pump and use a jam nut to remove through bolt (stud) from cylinder head, then remove pump with both brackets from vehicle. To install, reverse removal procedure and bleed hydraulic system.

OVERHAUL

Disassembly — 1) Remove outlet fitting and identification tag from pump. Invert pump assembly, and remove pump reservoir and seal using a soft-faced hammer. Again invert assembly, loosen and remove pump housing attaching hardware, and remove pump housing.

2) If necessary, remove housing cover, "O" ring seal, and pressure springs. Remove and discard pump cover gasket. Remove retainer end plate and upper pressure plate. Remove loose fitting dowel pin. **CAUTION** — Do not bend fixed dowel pin which remains in housing assembly.

3) Remove rotor assembly, being careful to prevent springs and slippers from falling out. **NOTE** — Further disassembly is not necessary unless lower pressure plate, housing plate, rotor shaft and/or seal are to be replaced. Invert pump and, using suitable puller, remove pump pulley. Clean pulley end of rotor shaft thoroughly, then remove pump rotor shaft. Remove lower pressure plate.

Reassembly — 1) Place plate and bushing assembly in a suitable holding fixture, with pulley side facing down. Position lower pressure plate in anchor pin with wide chamfered slots at center hole facing up. Lubricate rotor shaft, and insert shaft

into lower pressure plate and housing plate. If rotor was disassembled, position the cam insert with notch on O.D. of cam at the top and the arrow or open end of vendor letter mark pointing downward.

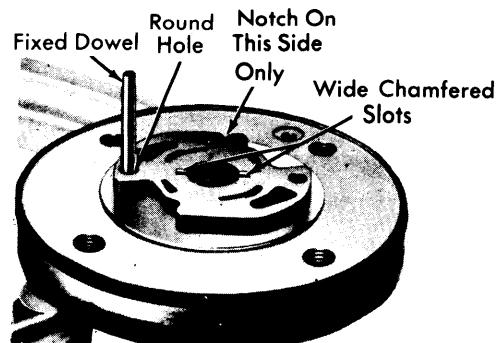

Fig. 1 Installing Lower Pressure Plate

2) Insert rotor in cam with double step in the I.D. of rotor facing upward. With rotor extended upward, approximately 1/2 way out of cam, insert a spring into rotor spring pocket, working in rotor cavity directly beneath cam notch. Use one of the slippers to compress spring, then install slipper, with groove in slipper facing toward cam notch. Flats on side of slipper should be on the left.

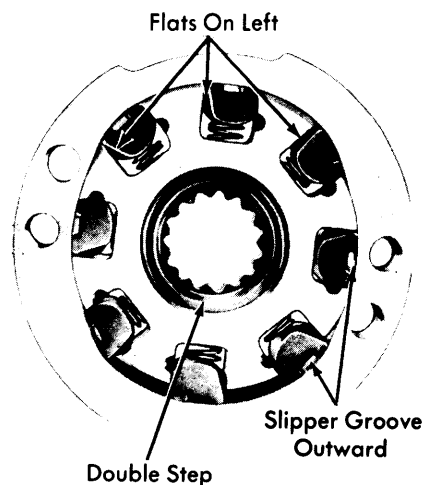

Fig. 2 Installing Spring and Slipper

3) Hold cam stationary and turn rotor either right or left, one space at a time, repeating slipper installation until all slippers have been installed. **CAUTION** — When turning rotor, use care to prevent springs and slippers already installed from falling out. Install cam and rotor assembly onto pump housing plate with fixed dowel passing through first hole to left of cam notch when arrow on cam O.D. is pointing toward lower pressure plate. If cam and rotor will not seat, turn rotor shaft slightly until splined teeth mesh, allowing cam and rotor to drop into position.

FORD-THOMPSON SLIPPER TYPE (Cont.)

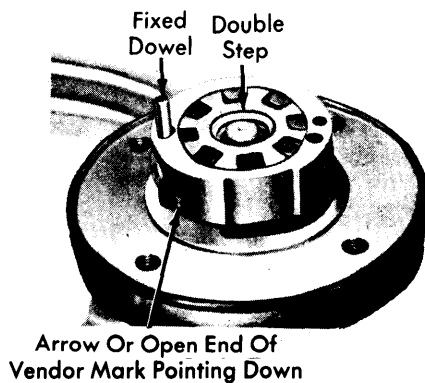

Fig. 3 Installing and Aligning Cam and Rotor

4) Insert loose fitting dowel through cam insert and lower plate into hole in housing plate assembly. Place upper pressure plate, with face having tapered notch down, against cam insert. Fixed dowel should pass through round dowel hole and loose dowel through elongated hole. **NOTE** — Slot between ears on pressure plate O.D. should line up with notch on cam insert O.D. Install retainer end plate so slot on end plate matches corresponding notches of upper pressure plate and cam.

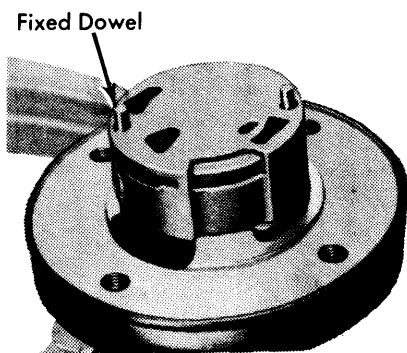

Fig. 4 Installing Pressure Plate over Fixed Dowel

5) Install pump valve assembly "O" ring seal into pump valve assembly. Place assembly on top of retainer end plate with large exhaust slot on pump valve in line with O.D. notches of previously assembled parts. Stack of parts must be fully seated. **NOTE** — If installed correctly then relief valve stem will be aligned with lube return hole in pump housing plate.

6) Install gasket on pump housing plate. Insert pressure plate springs into pockets in pump valve assembly. Use vaseline as an aid to hold springs in position. Using suitable tool (T-69-P-3B586-A Ford), plug intake hole in housing. Lubricate inside of housing and housing cover seal. Fabricate two studs ($\frac{3}{8}$ -16x1.55") to be used as positioning guides. Install one in housing plate bolt hole closest to drain hole, and one in bolt hole directly opposite first.

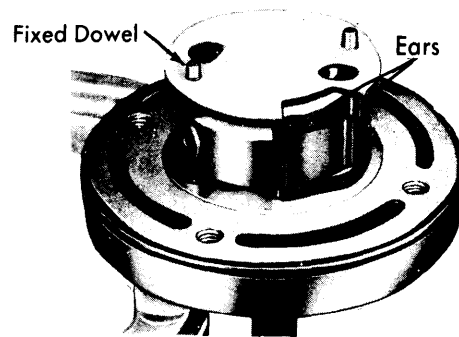

Fig. 5 Installing Retainer End Plate with Slot Matching Notches

7) Align small diameter lube hole in housing rim with lube hole in housing plate. Install housing, applying even downward pressure. **CAUTION** — Pressure plate springs must not be jarred or moved out of position. Remove guide studs. Install housing retaining bolts finger tight, then tighten retaining bolts until housing flange contacts gasket. Install $\frac{3}{8}$ -16 bolt, finger tight, into end of rotor shaft. Using a torque wrench, measure shaft rotational torque. If torque exceeds 15 INCH lbs., loosen retaining bolts slightly, rotate rotor shaft and retorque bolts. Continue this procedure until rotational torque is 15 INCH lbs. or less.

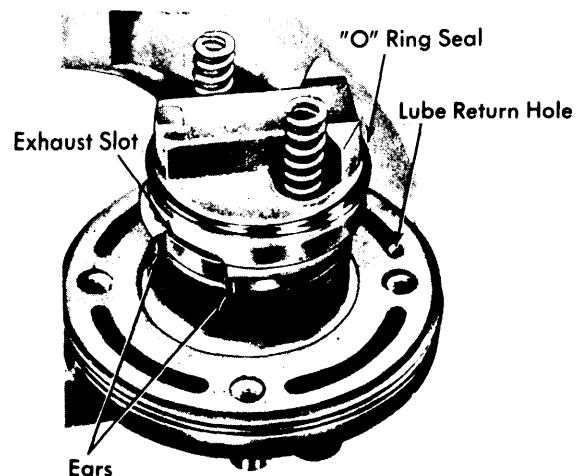

Fig. 6 Installing Valve and Pressure Spring

8) Shake pump assembly back and forth. If it rattles, pressure plate springs have fallen out of their seats and must be reinstalled. Install reservoir "O" ring on housing plate. Apply vaseline to seal and I.D. of reservoir flange. Install reservoir, aligning notch in reservoir flange with notch in O.D. of pump housing plate and bushing assembly. Tap at rear on outer corners to secure reservoir in place. Install identification tag and outlet valve fitting nut and tighten all nuts and bolts. Install pulley using suitable installing tool (T65P-3A733-A).

Power Steering Pumps

FORD-THOMPSON SLIPPER TYPE (Cont.)

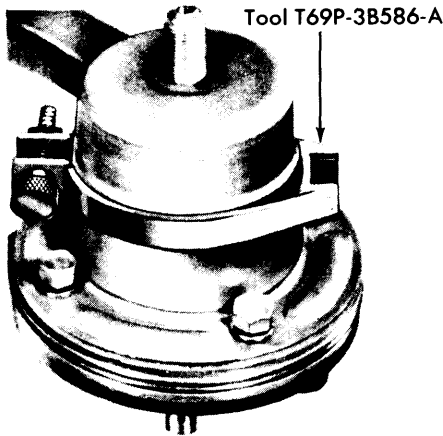

Fig. 7 Using Special Tool to Install Pump Housing

TIGHTENING SPECIFICATIONS

Application	Ft. Lbs.
Pump-to-Bracket	30-40
Bracket-to-Engine	
"F" Models	45-65
"U" Models	11-16
Pressure Hose-to-Pump Nut	20-30
Support Bracket-to-Engine	30-45
Reservoir Bracket-to-Engine	20-30

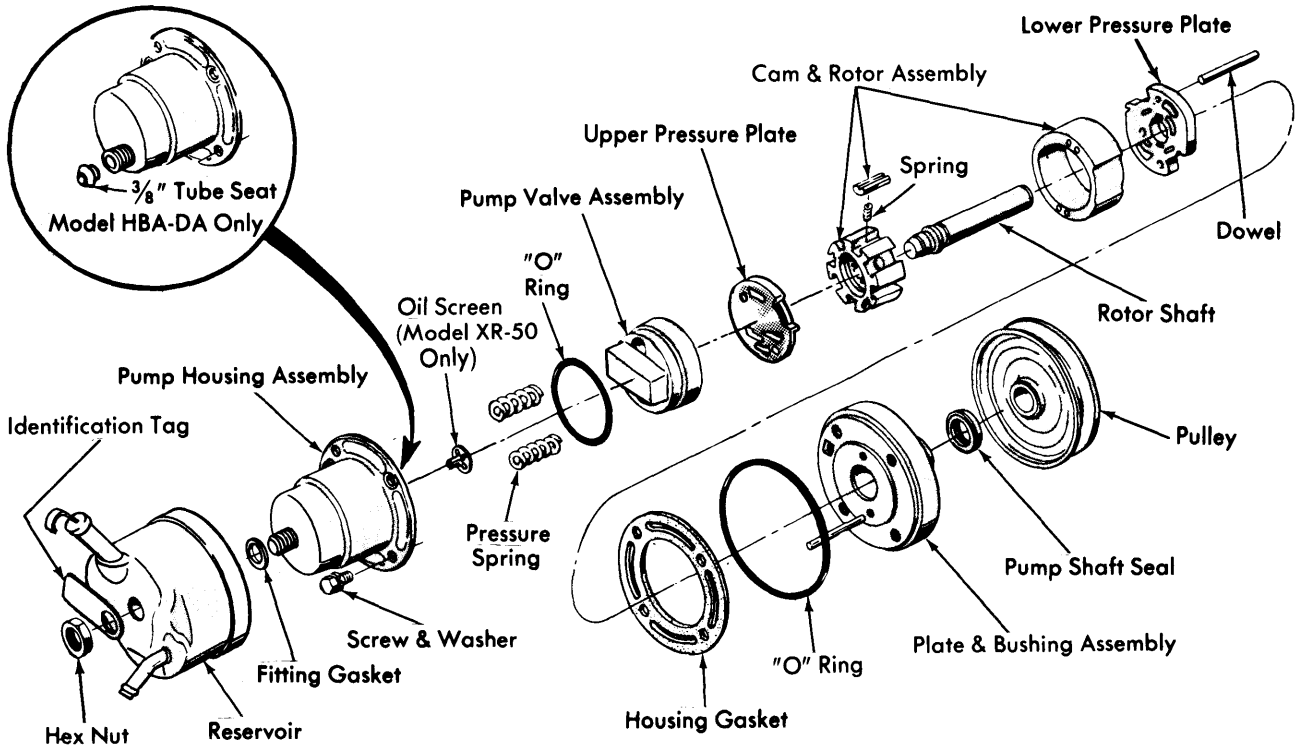

Fig. 8 Disassembled View of Ford-Thompson Power Steering Pump Assembly