

CHRYSLER CORP. CONSTANT CONTROL

Dodge
Plymouth

NOTE — Some models use other units. See Saginaw Rotary Valve power steering gear in this Section.

DESCRIPTION

Constant ratio power steering gear consists of a gearbox housing containing a sector shaft with forged sector gear, a rack-piston with gear teeth broached into the side of piston, and a worm shaft. Piston teeth and sector gear are in constant mesh with each other. Worm shaft connects rack-piston to steering shaft through a flexible coupling. Worm shaft is geared to rack-piston through recirculating ball contact. Steering control valve, mounted to top of steering gearbox, directs flow of fluid through the system. Fluid is supplied to the steering gear by an engine driven, constant displacement pump through a high pressure hose. Fluid is returned to pump reservoir from steering gear through a return hose.

LUBRICATION, TROUBLE SHOOTING & TESTING

See *Power Steering General Servicing* in this section.

ADJUSTMENT

SECTOR SHAFT PRELOAD

Disconnect steering center link from pitman arm. Start engine and run at idle speed, while turning steering wheel from stop to stop, counting number of turns from one stop to the other. Turn wheel back exactly $\frac{1}{2}$ number of turns to center gear. Loosen sector shaft adjuster screw until backlash is evident in pitman arm. Tighten adjuster until backlash just disappears, then continue tightening $\frac{3}{8}$ - $\frac{1}{2}$ turn from this position. Hold adjuster in position and tighten lock nut.

CONTROL VALVE CENTERING

Start engine, and tap on head or end plug of control valve assembly until unit is not self steering. Turn steering wheel from stop to stop several times to expel all air from system. Check fluid level in pump reservoir. With steering wheel in center position, start and stop engine several times, tapping on valve end plug or valve head, until there is no movement of steering wheel when engine is started or stopped. When steering wheel movement no longer exists, valve is centered. Tighten valve body attaching screws.

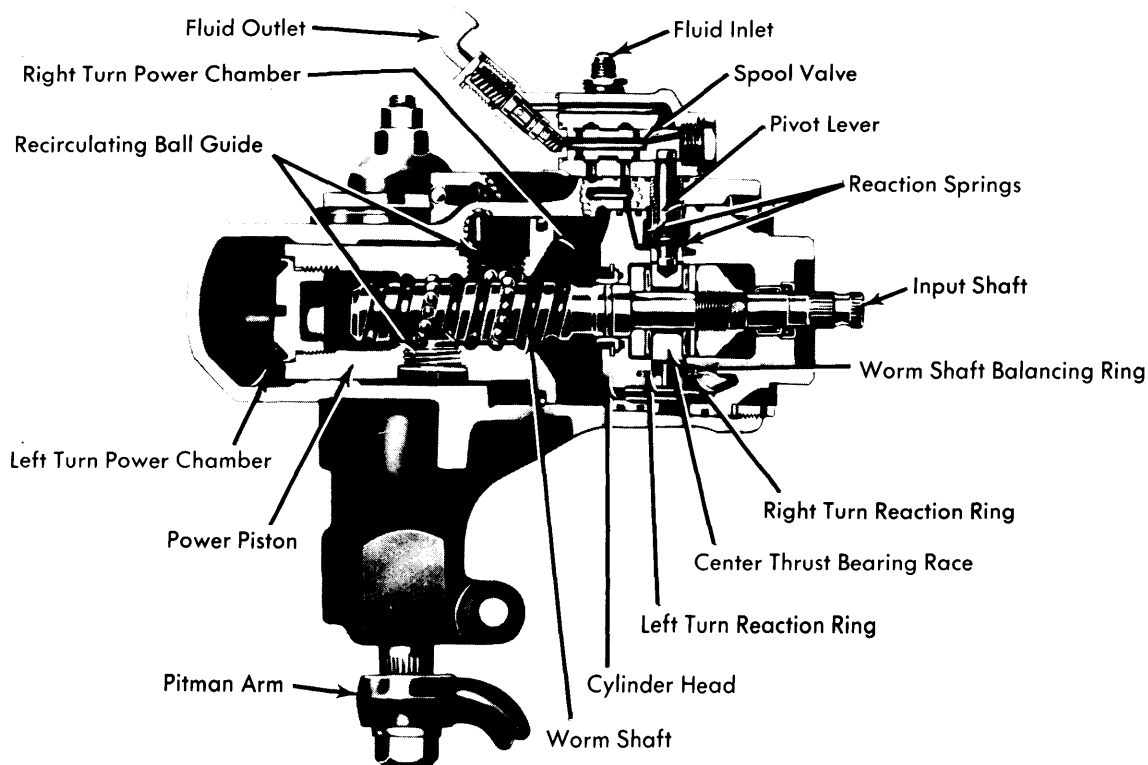

Fig. 1 Cutaway View of Steering Gear Assembly

CHRYSLER CORP. CONSTANT CONTROL (Cont.)

REMOVAL & INSTALLATION

STEERING GEAR

Removal — 1) Remove battery, disconnect wires from windshield washer pump, and place washer reservoir out of way. Disconnect fluid hoses at steering gear and cap ends to prevent loss of fluid. Raise vehicle on a hoist and disconnect flexible coupling from steering gear, leaving lower half of coupling on wormshaft.

2) Disconnect shift linkage at steering column. Remove steering arm shield (if equipped), remove nut and washer, then withdraw steering arm from sector shaft. Remove bolt on left side of gear, lower vehicle, and remove one of the two remaining mounting bolts.

3) Remove toe plate and steering column support bolts. Disconnect necessary wiring and remove column assembly. Raise vehicle on hoist, remove three bolts from left idler arm bracket, and swing bracket out of way. Remove remaining mounting bolt and withdraw steering gear from underside of vehicle through opening on inboard side of frame.

Installation — Reverse removal procedure and note the following: Make sure coupling half is installed on worm shaft before gear is installed in vehicle. After installation, refill system with power steering fluid and bleed system. See procedure given in *General Servicing* in this section.

OVERHAUL

STEERING GEAR

Disassembly — 1) Clean exterior of gear, then clamp in a soft-jawed vise. Rotate input shaft from stop-to-stop several times to drain fluid. Remove attaching screws, control valve, and "O" rings from housing. Remove pivot lever and spring by prying carefully under spherical head with a screwdriver. **CAUTION** — Use care not to collapse slotted end of valve lever as this will destroy bearing tolerances of spherical head.

2) Loosen sector shaft adjuster lock nut, then use a spanner wrench (C-3988) to remove sector shaft cover spanner nut. Rotate input shaft until sector teeth are in center position. Loosen steering power train retaining nut, then position a suitable holding tool (C-3876) on threaded end of sector shaft. Slide tool into housing until both tool and shaft are engaged with bearings.

3) Rotate input shaft to full left turn position in order to compress power train components. Remove power train retaining nut and housing end tang washer. With power train fully compressed, pry on rack-piston teeth with a screwdriver, using sector shaft as a fulcrum, and remove complete power train assembly.

CAUTION — It is important that cylinder head, center race and spacer assembly, and housing head be maintained in close contact with each other to eliminate the possibility of reaction rings becoming disengaged from grooves in cylinder head and housing head, and to prevent center spacer from separating from center race and becoming cocked in housing.

4) Position power train assembly vertically in a soft-jawed vise. Raise housing head until input shaft oil seal just clears end of input shaft. Position suitable arbor tool (C-3929) on top of input shaft and extending into oil seal. Keeping arbor in position, pull up on housing head until arbor is fully positioned in bearing, then remove head and arbor as a unit.

CAUTION — If input shaft oil seal is to be replaced, perform operation with housing head assembled in steering gear housing.

5) Remove large "O" ring from groove in housing head. Remove reaction seal by directing compressed air into ferrule chamber. Inspect all grooves for burrs. Remove the reaction spring, reaction ring, worm balancing ring, and spacer.

6) While holding worm shaft from turning, turn nut to release staked portions from knurled section of shaft. **NOTE** — Wire brush knurled section, and blow out nut and worm shaft to remove metal particles. Remove nut, upper thrust bearing race, and upper thrust bearing. Remove center bearing race, lower thrust bearing, and lower thrust bearing race. Remove lower reaction ring, and spring. Remove cylinder head assembly.

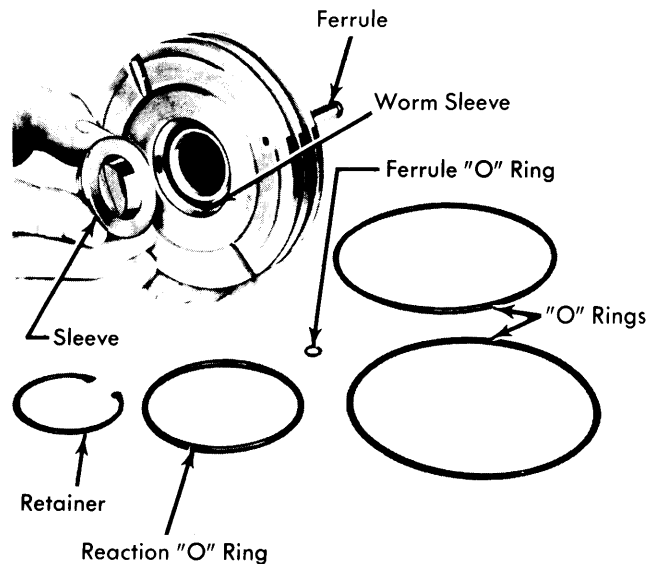

Fig. 2 Removing the Cylinder Head Seals

7) Remove "O" rings from outer grooves in cylinder head. Remove reaction "O" ring from groove in face of cylinder head by directing compressed air into oil hole between two "O" ring grooves. Remove snap ring, sleeve, and rectangular oil seal ring from cylinder head counterbore. Test operation of worm shaft. Torque required to rotate worm shaft through its travel in or out of rack piston must not exceed 1½ INCH lbs. **NOTE** — Worm and piston are serviced as an assembly and should not be disassembled.

8) With piston assembly mounted in a soft-jawed vise, rack teeth facing up, and worm in its approximate center of travel, measure shaft side play of shaft at a point 2¼" from piston flange. Side play should not exceed .008" when end of worm is lifted with a force of one pound (see illustration).

CHRYSLER CORP. CONSTANT CONTROL (Cont.)

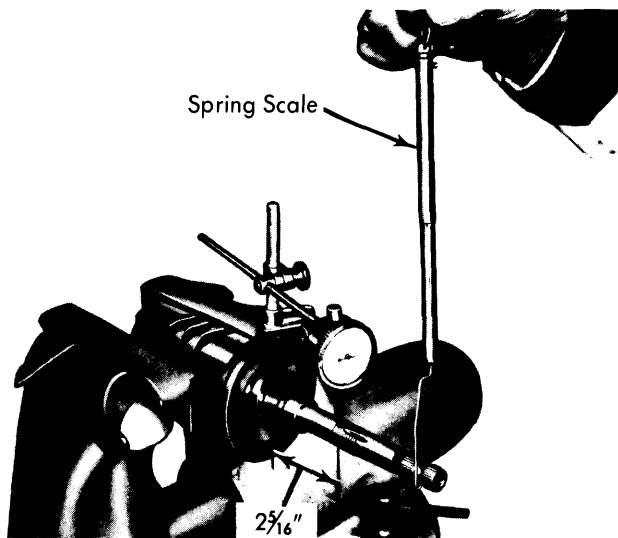

Fig. 3 Checking Shaft Side Play Using a Dial Indicator and Spring Scale

Reassembly — 1) Inspect condition of rubber sealing ring located under cast iron piston ring, and replace if necessary. To install cast iron piston ring, slide new ring into place in piston groove, then place piston and ring assembly into suitable holding fixture (C-3676) with lower part of piston and ring resting against land of tool. Press down on piston to seat ring in groove, forcing open ends of ring out for ease of locking ring.

2) Clamp piston assembly in a soft-jawed vise with worm shaft pointing up. Inspect cylinder head ferrule oil passage for obstructions, and inspect lands for burrs. Lubricate large "O" rings and install them in cylinder head grooves. Install worm sleeve seal, sleeve, and snap ring. **CAUTION** — Make sure snap ring is fully seated in groove. Install lower reaction "O" ring in cylinder head groove.

3) Slide cylinder head assembly, ferrule end up, onto worm shaft. **CAUTION** — Check worm shaft seal ring, making sure gap is closed, to avoid damaging the ring as the cylinder head moves against the piston flange. Lubricate power train parts with power steering fluid, and install in the following order; lower thrust bearing race, lower thrust bearing, lower reaction spring, lower reaction ring, center bearing race, upper thrust bearing, upper thrust bearing race, and thrust bearing adjusting nut. Make sure small hole in reaction spring is over ferrule, lower reaction ring protrudes through reaction spring, and adjusting nut is loosely installed.

4) Turn worm shaft $\frac{1}{2}$ turn clockwise. Hold shaft in this position using the splined nut, then tighten the adjusting nut to 50 ft. lbs. to prestretch threads. Loosen adjusting nut. Place several rounds of cord around the center bearing race. Make a loop in end of cord and attach a suitable distributor breaker arm spring scale to loop. Pulling on cord will cause bearing race to rotate. Retighten worm bearing adjusting nut while pulling on cord with spring scale. Adjusting nut is properly tightened when reading on spring scale is 16-24 ozs. **NOTE** — Preferred reading is 20 ozs. with bearing race turning.

5) Stake upper part of worm shaft bearing adjusting nut into knurled area of shaft. Hold a $\frac{1}{4}$ " flat end punch on centerline of worm shaft end at a slight angle to nut flange. Strike punch a sharp blow with hammer and test preload. **NOTE** — If adjusting nut moved during staking operation, it can be corrected by striking the nut a glancing blow in the direction required to regain proper preload. After retesting for proper preload, stake the nut at three more locations 90° apart around upper part of nut. To test total staking, apply 20 ft. lbs. of torque in each direction. If nut does not move, staking operation is correct.

6) Position spacer assembly over center race, engaging dowel pin of spacer in slot of race, and slot of spacer entered over cylinder head ferrule. This aligns valve pivot lever hole in center bearing race with valve pivot lever hole in center bearing spacer assembly. **NOTE** — The small "O" ring for the ferrule groove should not be installed until after upper reaction spring and spacer have been installed.

7) Install upper reaction ring on center race, and spacer, with flange down against spacer. Install upper reaction spring over reaction ring, with cylinder head ferrule through hole in reaction spring. Install worm balancing ring (without flange) inside upper reaction ring. Lubricate ferrule "O" ring with Vaseline, and install in groove on cylinder head ferrule. If oil seal was removed from housing head, install new seal using seal installer (C-3650) to drive seal in until tool bottoms on support.

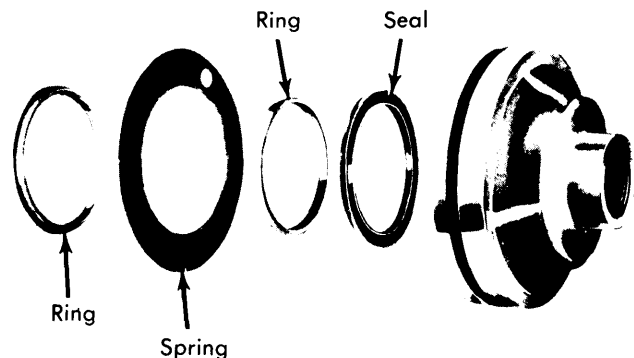

Fig. 4 Installing Reaction Seal and Ring

8) Lubricate and install reaction seal in groove in face of housing head with flat side of seal out. Install "O" ring in groove in housing head. Slide housing head and arbor assembly over worm shaft, engaging cylinder head ferrule and "O" ring and making sure reaction rings enter circular groove in housing head. Power train is now ready for installation in housing.

9) Lubricate power train bore of housing and install power train assembly while noting the following: Keep worm turned fully counterclockwise to keep reaction rings from coming out of their grooves. Piston teeth must be facing to the right, and valve lever hole in center race and spacer must be in the "up" position. **CAUTION** — Make sure cylinder head is **bottomed** on housing shoulder.

Power Steering Gears

CHRYSLER CORP. CONSTANT CONTROL (Cont.)

10) Align valve lever hole in center bearing race and center spacer with lever hole in gear housing. Install valve pivot lever, double bearing end first, through hole in housing until engaged in center race and spacer. **CAUTION** — Slots in valve lever must be parallel to worm shaft in order to engage anti-rotation pin in center race.

11) Lightly tap on end of lever to seat lower pivot pin in center race. Center lever in hole by turning housing head by tapping on a reinforcing rib with a hammer and drift. Install housing head tang washer to index with groove in housing. Install

spanner nut, making sure valve lever remains centered in hole in housing. **NOTE** — Turn worm shaft until piston bottoms in both directions, and note valve lever action. Lever must center in hole and snap back to its center position when worm tension is relieved.

12) Install valve lever spring, small end first. Set power piston at center of travel, install sector shaft and cover assembly, and center sector teeth with piston rack teeth. Make sure "O" ring is properly installed on cover. Install sector cover lock nut.

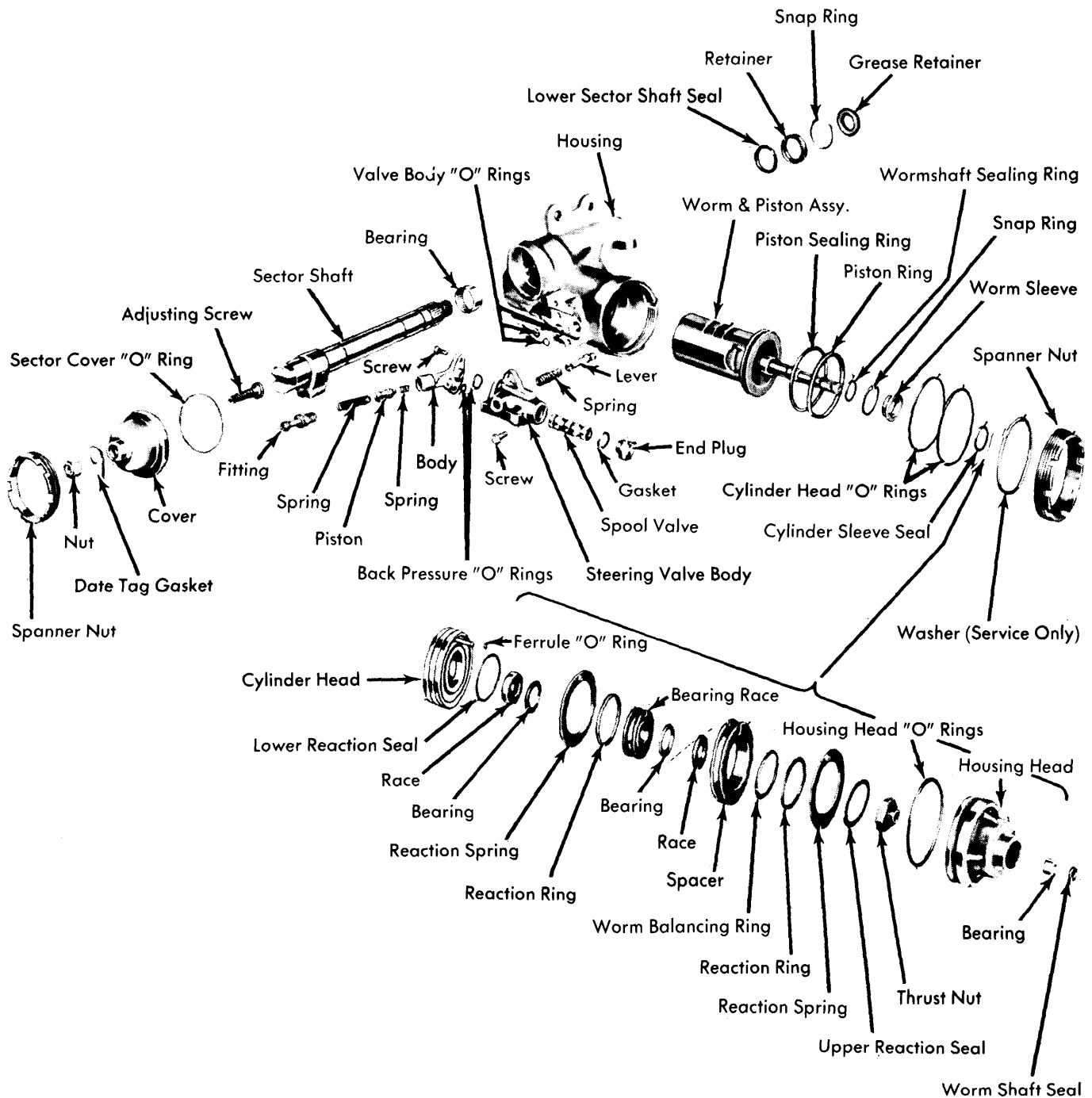

Fig. 5 Exploded View of Steering Gear Components

CHRYSLER CORP. CONSTANT CONTROL (Cont.)

13) Install control valve body on housing, making sure valve pivot lever enters hole in valve spool. Be sure "O" ring seals are in place. Tighten control valve attaching screws. Install new sector shaft seal, followed by seal back-up washer, and snap ring. Install new grease retainer.

2) Place two half rings (SP-1932) and tool retainer ring over both portions of tool. Turn tool nut counterclockwise to remove retainer. Remove oil seal snap ring, and seal backup washer. Remove inner seal in same manner, and using same tools as for grease retainer removal.

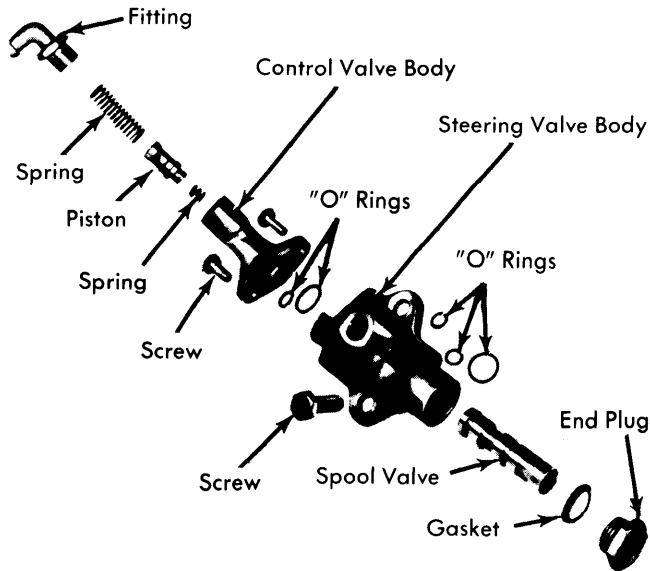

Fig. 6 Disassembled View of Control Valve Assembly

SECTOR SHAFT OIL SEAL

NOTE — Sector shaft oil seal may be replaced without removing steering gear from vehicle.

Disassembly — 1) Remove pitman arm attaching nut. Disconnect pitman arm from sector shaft. Slide suitable adapter (SP-3056) over end of sector shaft, and thread tool nut onto sector shaft. Maintain pressure on threaded adapter with tool nut while screwing adapter far enough to engage metal portion of grease retainer.

Reassembly — 1) Place new seal, lip facing down, on a flat surface and lubricate inner diameter with power steering fluid. Insert seal protective sleeve in seal, and position seal on sector shaft with lip of seal toward housing. Place tool adapter (SP-3828) with long step against new seal. Install tool nut on sector shaft and tighten nut until shoulder of adapter contacts gear housing.

2) Remove tool nut, adapter, and protector, then install seal backup washer. Install oil seal snap ring with sharp edge out. Fill housing cavity outside retainer and snap ring with a multi-purpose chassis grease. Position oil seal in housing bore.

3) Position adapter tool (SP-3052) with short step of lip against seal. Install tool nut on sector shaft, then tighten until shoulder contacts gear housing. Remove tool, and position steering gear and steering wheel in straight ahead position. Install pitman arm and attaching nut.

TIGHTENING SPECIFICATIONS

Application	Ft. Lbs.
Gear Housing-to-Frame	100
Gear Sector Shaft Adjuster Lock Nut	28
Sector Shaft Cover Spanner Nut	155
Pitman Arm Nut	175
Housing Head Spanner Nut	162
Valve Body End Plug	50
Steering Wheel Nut	28
Application	INCH Lbs.
Steering Column Support Nut	140
Valve Body Attaching Screw	200