

CHRYSLER CORP.

Dodge
Plymouth

DESCRIPTION

The steering columns are non-collapsible assemblies which contain the steering shaft supported by upper and lower bearings. In both columns used with both automatic or manual transmission, the shift linkage is integral. Some columns have a tilting feature that allows adjustment of the steering wheel angle. On some Motor Home Chassis the column angle itself is adjustable. All columns have an integral ignition switch and locking device.

REMOVAL & INSTALLATION

"B" & "PB" MODELS

Removal - 1) Disconnect battery ground cable. Rotate steering wheel to position shaft coupling at steering gear for removal of roll pin. Drive roll pin out from flexible rubber/fabric coupling. Remove clips and washers which retain transmission shift rod(s) to steering column lower end.

2) Lift floor mat and loosen two bolts in floor plate "O" ring retainer on column. Remove floor plate-to-floor pan attaching screws. Unplug steering column wiring connectors under instru-

ment panel. Loosen two bolts which hold steering column clamp to instrument panel. Pry coupling free of steering gear worm shaft. Remove clamp bolts from instrument panel and work column up and out of vehicle.

Installation - 1) Insert column assembly through floor pan opening, being careful not to damage paint or trim. With front wheel in straight-ahead position, master splines on worm shaft and coupling aligned, engage coupling with worm shaft and install new roll pin.

2) Hold column assembly with bracket against instrument panel support. Install but do not tighten clamp bolts. Position floor plate over floor opening, centering it around column, then install retaining bolts finger tight.

3) As the floor plate retaining bolts are tightened to final torque, column must be centered around steering shaft lower end. Spread rubber cement on outside diameter to retain dust seal which now can be slid up into place where shaft enters column.

4) Install transmission shift linkage to lower end of steering column. Plug in steering column wiring connectors under instrument panel. Connect battery ground cable and test operation of horn and turn signal.

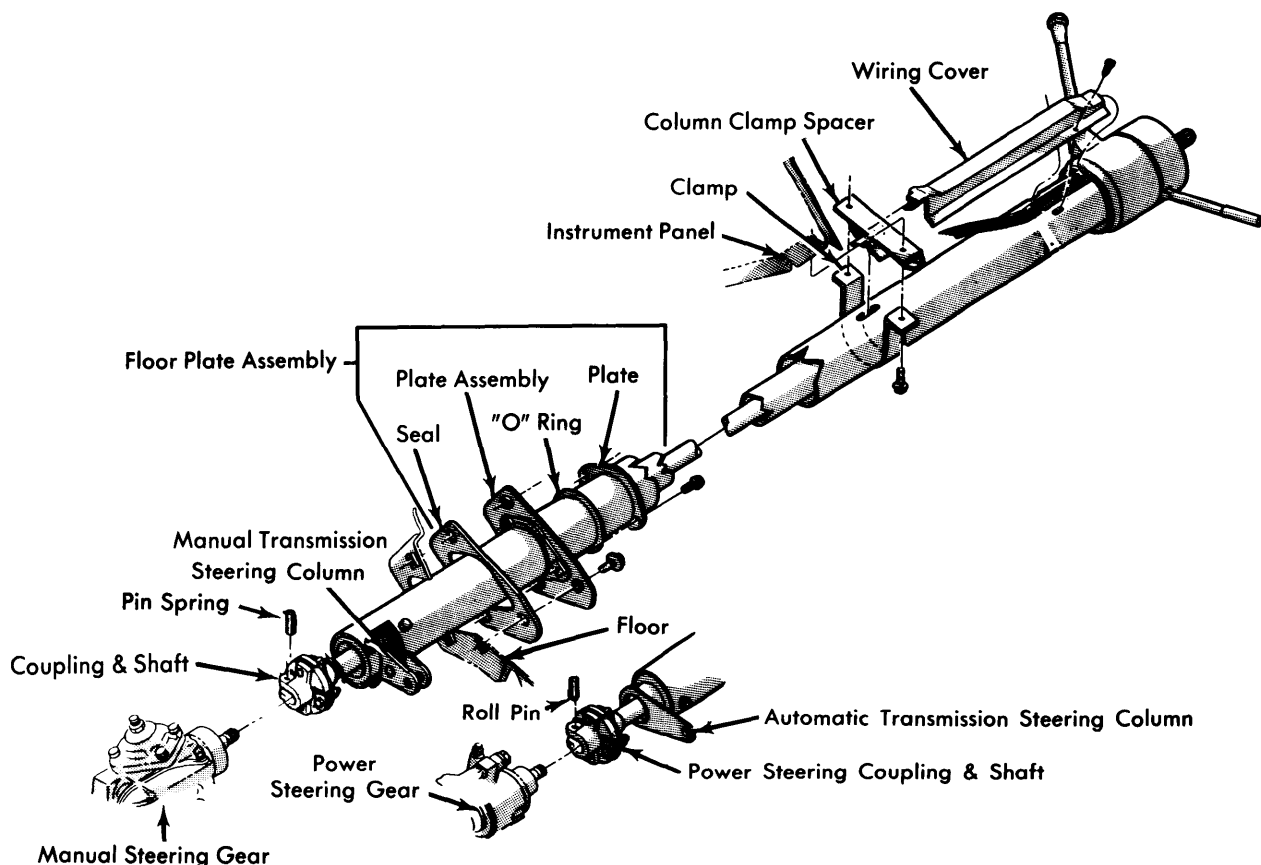

Fig. 1 Steering Column Installation For "B" & "PB" Models

Steering Columns

CHRYSLER CORP. (Cont.)

"M" MODELS

Removal — 1) Disconnect battery ground cable. Remove "Pot" coupling roll pin. Disconnect electrical wiring connector at steering column jacket. Remove horn pad assembly by removing two retaining screws from behind steering wheel.

2) Remove steering wheel retaining nut and washer. Install suitable wheel puller (C-3428B) and remove steering wheel. **CAUTION** — Use proper tool to remove wheel; force or hammering will result in damage to wheel or steering column. Remove four floor plate retaining bolts. Remove column-to-instrument panel retaining bracket and lift column into interior.

Installation — 1) With floor plate and boot on column, slide column through opening in floor from inside. Position column to center steering shaft bearing blocks in coupling. Tighten clamp nut.

2) Install steering column upper bracket bolts and tighten finger tight. Center shaft in column with wheels in straight ahead position. Center boot and floor plate and tighten floor plate mounting screws.

3) Tighten steering column bracket bolts and place steering wheel on steering shaft with master splines aligned. Install retaining nut and washer and tighten. **CAUTION** — Use nut to draw wheel onto shaft. Do not drive wheel onto shaft. Install horn switch parts previously removed from steering wheel. Connect horn switch wire. Connect wiring connectors at steering column jacket. Connect battery ground cable.

ALL OTHER MODELS

Removal — 1) Disconnect battery ground cable. Disconnect shift linkage or linkages from lower end of steering column. Remove two nuts and lockwashers from flexible coupling. On "W" models, remove "Pot" type coupling roll pin. Disconnect electrical wiring connector at steering column jacket. Remove horn pad and assembly; disconnect horn wire and remove horn switch.

2) Remove steering wheel retaining nut and washer. Using a suitable wheel puller (C-3428B), remove steering wheel. **CAUTION** — Use proper tool to remove wheel; force or hammering will result in damage to wheel or steering column. Loosen "O" ring retaining plate screws and remove support plate screws. Remove trim panel and nuts or bolts attaching steering column clamp to instrument panel support. Lift column out through cab.

Installation — 1) Insert steering column assembly through firewall opening. Connect steering column coupling flange with coupling on steering gear worm shaft. **NOTE** — Position steering column so flange face is parallel to fabric coupling face to prevent undue stress on fabric coupling. On "W" models, position column to center steering shaft bearing blocks in "Pot" coupling.

2) Install two steering column upper bracket bolts and tighten finger tight. With front wheels in straight position, using suitable centering tool (C-4134), center shaft in shift tube. Position support plate to firewall; tighten screws. Slide "O" ring into position on support plate and secure with two screws.

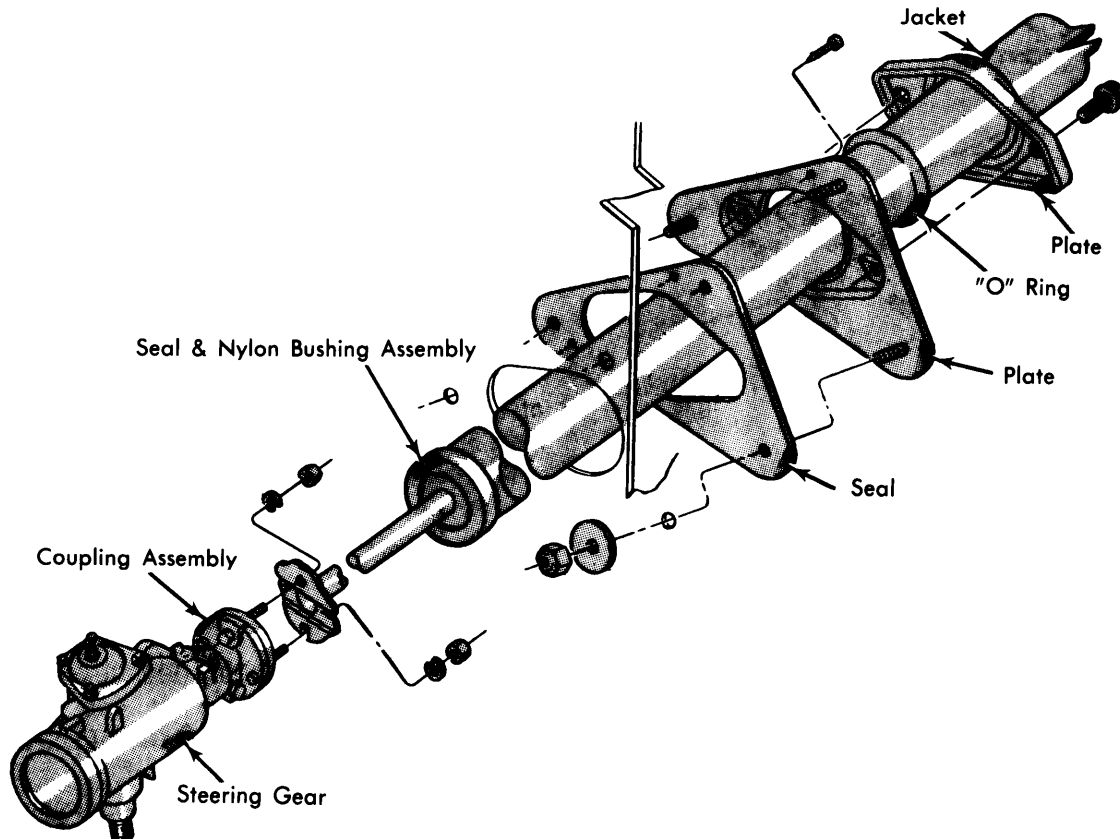

Fig. 2 Steering Column Installation For All Models Except "B", "PB" & "M"

CHRYSLER CORP. (Cont.)

Tighten steering column bracket bolts, and tighten steering column coupling-to-steering gear flange nuts. Remove centering tool.

3) Connect gearshift indicator pointer to operating bracket on shift housing in its approximate original location. Slowly move gearshift lever from "L" to "P" pausing briefly at each selector position. Indicator pointer must align with each selector position. If necessary, loosen bolt and readjust to align pointer correctly.

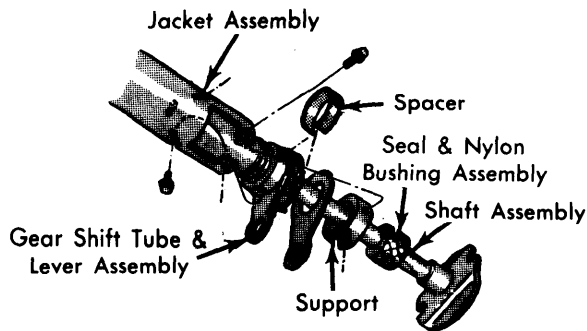

Fig. 3 Manual Transmission Lower Column For All Models Except "B", "PB" & "M"

4) Place steering wheel on steering shaft with master splines aligned. Install retaining nut and washer, tighten nut. **CAUTION** — Do not drive wheel on shaft, draw wheel down with retaining nut. Install horn switch parts previously removed from steering wheel. Connect horn switch wire.

5) Connect wiring connectors at steering column jacket. Connect battery ground cable, test operation of lights and horn. Connect and adjust gearshift linkage and check for proper operation.

OVERHAUL

"B" & "PB" MODELS

Disassembly — 1) Remove steering wheel and directional signal switch. See *Steering Wheel & Column Switches* in this section. Remove snap ring from upper groove on steering shaft. Install suitable steering shaft removal tool (C-4044) and push shaft out of bearing. Remove shaft through lower end of column. Loosen two bearing housing retaining nuts and back off flush to end of bolts. Push both bolts down and hold with thumbs, so nuts are against housing to release square bolt heads from square holes in column jacket. Then lift housing from jacket.

2) Use masking tape to protect paint, then drive out shift lever retaining pin using a deep socket to back up housing. If vehicle is equipped with manual transmission, go to step 3). If vehicle is equipped with automatic transmission, go to step 4).

3) Pull shift lever out of shift housing and remove shift housing and spring washer from column jacket. At lower end of column, remove three screws from shift tube and lever support and three screws from shift tube adjustable bushing. Align levers with cut out in bottom of column jacket. Push on upper end of the shift tube to remove all parts from jacket. Continue disassembly by proceeding to step 5).

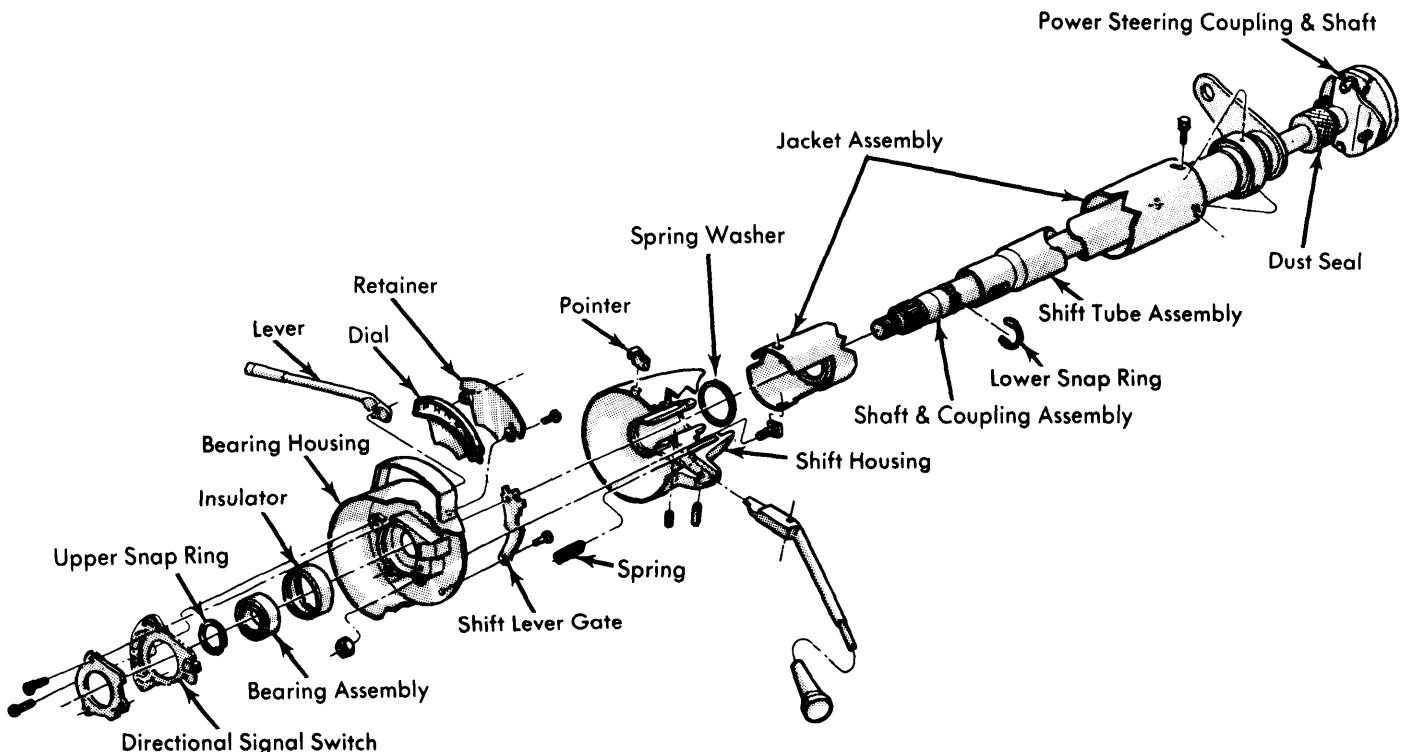

Fig. 4 Steering Column Assembly for "B" & "PB" Models (Column For Automatic Transmission Models Is Shown)

CHRYSLER CORP. (Cont.)

4) On vehicles equipped with automatic transmission, remove shift lever and shift lever gate spring from shift housing. Loosen shift tube lock screw in shift housing and straighten tabs at top of shift tube so they will clear shift housing. Remove shift housing and spring washer from column jacket. Remove shift tube support retaining screws from lower end of column jacket and remove parts from column jacket.

5) Remove spring washer seat from upper end of jacket. Remove "O" ring and floor plate assembly components from lower end of jacket.

Reassembly — 1) Place "O" ring and floor plate components on lower end of column jacket. Insert spring washer seat in upper end of jacket and push down to bottom against tabs in jacket. If vehicle is equipped with automatic transmission, proceed on to step 5) to continue with reassembly. If vehicle is equipped with manual transmission, proceed on to step 2).

2) Rotate bushing on shift tube so screw holes will align with slots in jacket as shift tube is installed into jacket. Install assembly into jacket but do not tighten bushing adjustment screws at this time. Place lever spacer up against 2nd-3rd shift lever on shift tube. Install 1st-Reverse lever on shift tube against lever spacer and install lower support for shift tube and levers. Tighten screws.

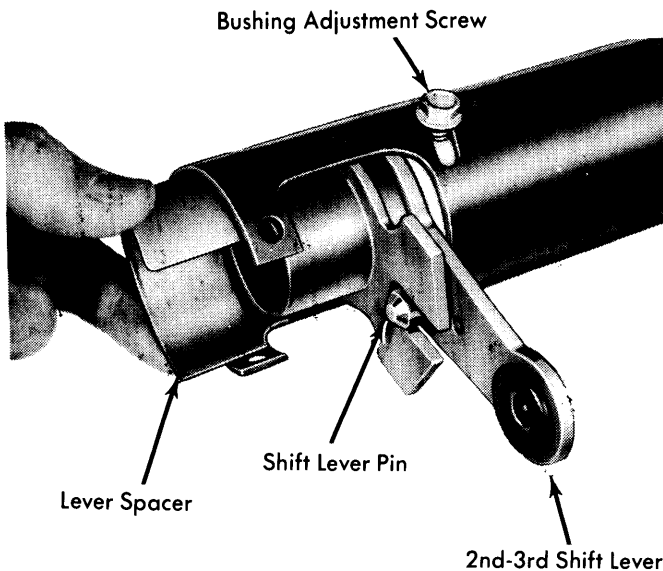

Fig. 5 Installing Shift Lever And Spacer

3) Place spring washer on shift housing using grease to hold it in place. Install shift housing over jacket while guiding shift tube key into slot in housing. Insert shift lever with insulator ring into shift housing and drive in retaining roll pin. Support housing with socket to protect paint.

4) Install bearing housing on jacket while holding thumbs on retaining bolts so that square heads will slip outside and down into square holes in jacket. Tighten nuts down alternately and evenly. At lower end, adjust shift lever end play by rotating bushing screws in jacket slots so that end play is eliminated but levers move easily. Tighten all attaching screws, and then proceed on to step 7).

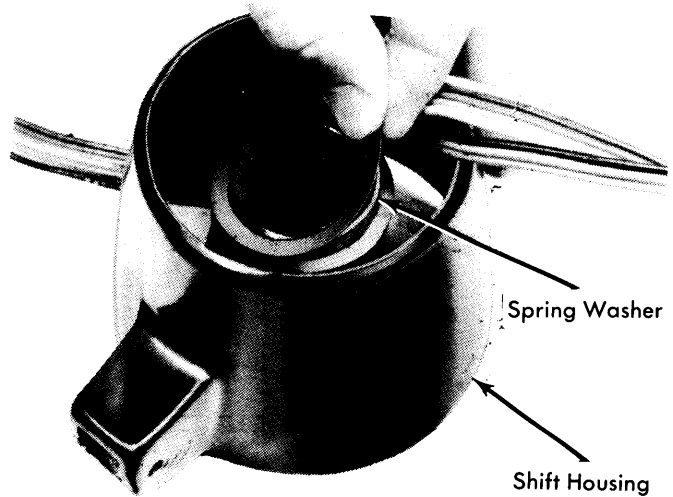

Fig. 6 Installing Spring Washer Into Shift Housing

5) On vehicles with automatic transmissions, proceed as follows: Slide shift tube and support up into column jacket. Align holes and install screws through jacket into support and tighten. Place spring washer on shift housing using grease to hold it in place. Install shift housing over jacket while guiding shift tube key into slot in housing. Hold parts firmly together and tighten lock screw in shift housing. Bend corners of slot in shift tube out against shift housing casting.

6) Insert shift lever and shift lever gate spring into shift housing and drive in retaining roll pin. Support housing with socket to protect paint. Install bearing housing on jacket while holding thumbs on retaining bolts so that square heads will slip outside and down into square holes in jacket. Turn nuts down alternately and evenly to make sure bolt heads seize jacket.

7) Insert steering shaft assembly, including lower snap ring, into column and guide upper end through bearing. Place suitable steering shaft installing tool (C-3879) on shaft and draw shaft into bearing. Remove tool and install upper snap ring on shaft next to bearing. Position directional signal switch and retainer plate in bearing housing and secure with three screws. Install steering wheel.

"M" MODELS

Disassembly — 1) Clamp column in vise. Remove screw and remove directional signal lever from column. Remove screws retaining directional signal and upper bearing. Remove retainer and lift switch upward and out of the way. Remove snap ring from upper end of steering shaft. Remove three screws which hold bearing housing to lock housing. **CAUTION** — These screws must be removed before steering shaft removal.

2) Install suitable steering shaft removal tool (C-4044), and press shaft out of bearing. Remove tool, and remove bearing housing from shaft. Remove bearing lower snap ring from shaft. Remove shaft through lower end of column. Place lock

CHRYSLER CORP. (Cont.)

cylinder in "LOCK" position and remove key. Insert small screwdriver or similar tool into lock cylinder release hole and push in to release spring-loaded lock retainer. Pull lock cylinder out of housing bore at same time and remove ignition switch assembly. Remove four lock housing-to-column jacket hex head retaining screws, and remove both housing and spring washer from jacket.

2) Insert steering shaft assembly into column. Install bearing lower snap ring on steering shaft. Place rubber insulator with ground staple over column upper bearing and install assembly into bearing housing bore. Use a soap solution or rubber lubricant to ease installation. Install directional signal switch in bearing housing, feeding wires through opening in housing. Install retainer plate over switch and install and tighten screws. Install signal lever and tighten screw.

Reassembly - 1) Install boot and floor plate on lower end of column jacket. Install spring washer and both housings. Position ignition switch in center detent ("OFF") position. Feed wires down through space between housing and jacket. Position switch in housing and tighten three counting screws. With lock cylinder in "LOCK" position and key removed, insert cylinder into lock housing. Press cylinder into place until contact is made with pin on ignition switch cam. Insert key into cylinder and rotate lock until slot in cylinder plate lines up with pin. Press key cylinder in further until snap is heard.

3) Position bearing housing assembly on column jacket, feeding wires through space between lower housing and jacket. When installing housing, steering shaft must be drawn, not pushed, through bearing, using bearing inner race as a reaction member, or damage to lock housing components or bearings could result. Install housing on steering shaft, using suitable tool (C-3879). Remove tool and install upper snap ring on shaft. Install three bearing housing-to-lock housing screws and tighten.

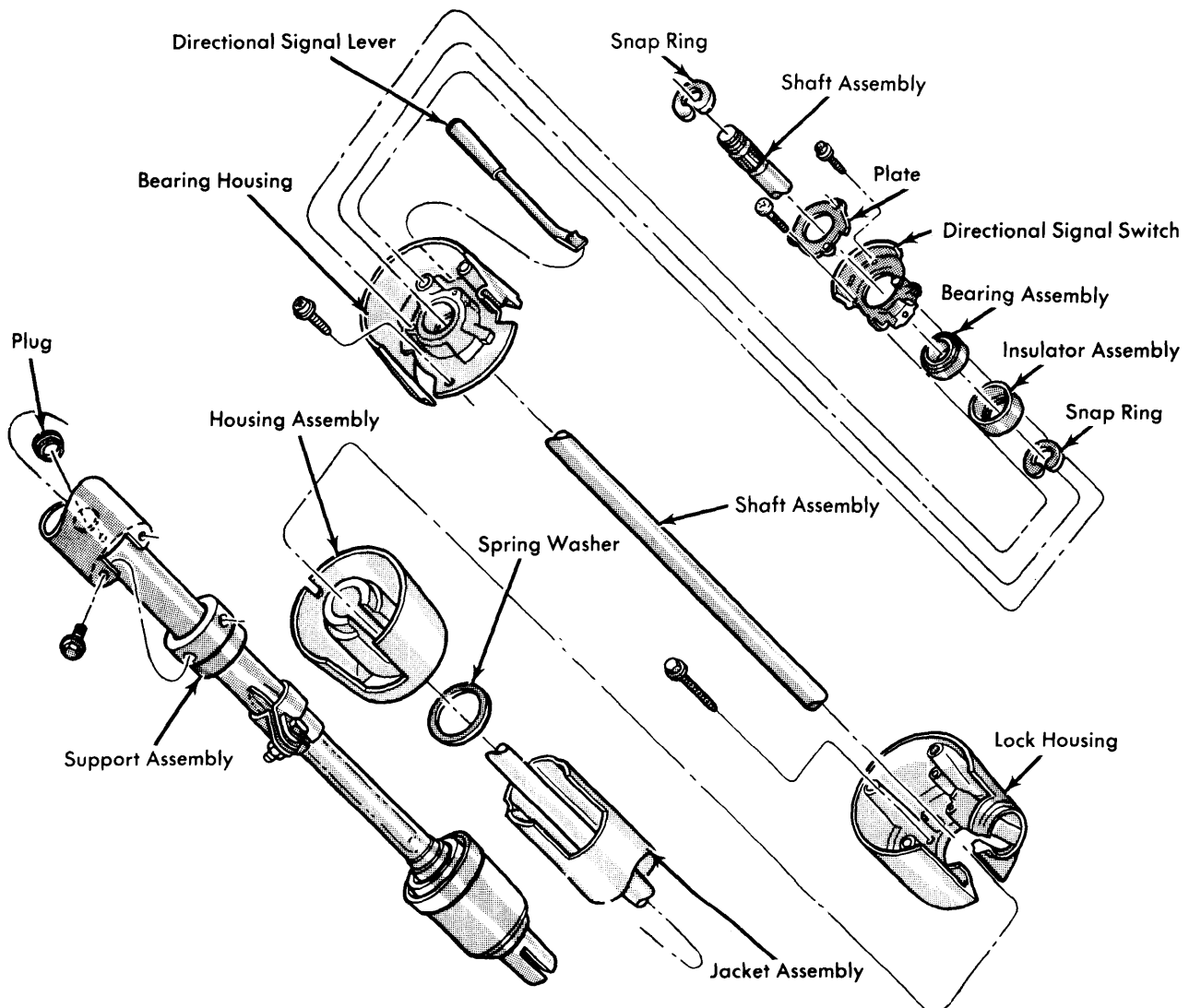

Fig. 7 Disassembled Steering Column Assembly For "M" Models

CHRYSLER CORP. (Cont.)

ALL OTHER MODELS

Disassembly — 1) Clamp column assembly in vise. Drive out gearshift lever pin, then remove lever and spring (if present), from housing. Remove directional signal switch and upper bearing retainer screws. Remove retainer and lift switch upward out of the way. Remove directional signal lever. Remove two retaining screws and lift lamp assembly out of the way (automatic transmission only).

2) Remove snap ring from upper end of steering shaft. Remove three screws which hold bearing housing to lock housing. **CAUTION** — These screws must be removed before steering shaft removal. Install suitable steering shaft removal tool (C-4044) and press shaft out of bearing. Remove bearing housing from shaft. Remove bearing lower snap ring from shaft, then remove shaft through lower end of column.

3) Place cylinder in "LOCK" position and remove key. Insert a small diameter screwdriver or similar tool into lock cylinder release hole and push in to release spring loaded lock retainer. At same time pull lock cylinder out of housing bore and remove ignition switch assembly. Remove four lock housing to column jacket hex head retaining screws and remove housing from jacket.

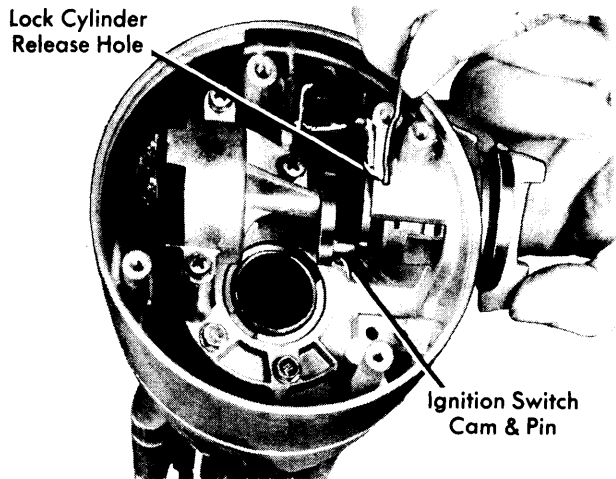

Fig. 8 Removing Lock Cylinder From Steering Column

4) **NOTE** — Use following procedure for vehicles equipped with manual transmission. Go to Step 5) for vehicles equipped with automatic transmission. Straighten tabs at top of shift tube which are bent outward against shift housing casting. Pull shift lever out of shift housing and remove shift housing and spring washer from column jacket. At lower end of column, remove three screws from shift tube and lever support and three screws from shift tube adjustable bushing. Align levers with cut out in bottom of column jacket. Push on upper end of shift tube to remove all parts from jacket. Go to step 6) to continue disassembly procedure.

5) On models with automatic transmission, remove shift lever and gate spring from shift housing. Loosen shift tube lock screw in shift housing. Straighten tabs at top of shift tube so

they will clear shift housing and remove shift housing and spring washer from column jacket. Remove shift tube support retaining screws from lower end of column jacket and remove parts from column jacket.

6) Remove spring washer from upper end of jacket. Remove "O" ring and support plate assembly parts from lower end of jacket. Examine components for excessive wear and replace as required.

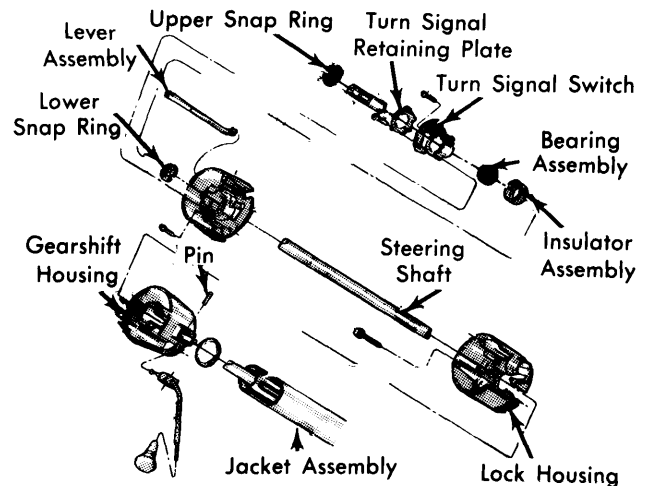

Fig. 9 Steering Column For Manual Transmissions On All Models Except "B", "PB" & "M"

Reassembly — 1) **NOTE** — Use following procedure for vehicles equipped with manual transmission. Go to step 4) for vehicles equipped with automatic transmission. Install "O" ring retainer, "O" ring, and floor plate on lower end of column jacket. Rotate bushing at lower end of shift tube so screw holes will align with slots in jacket as shift tube is installed.

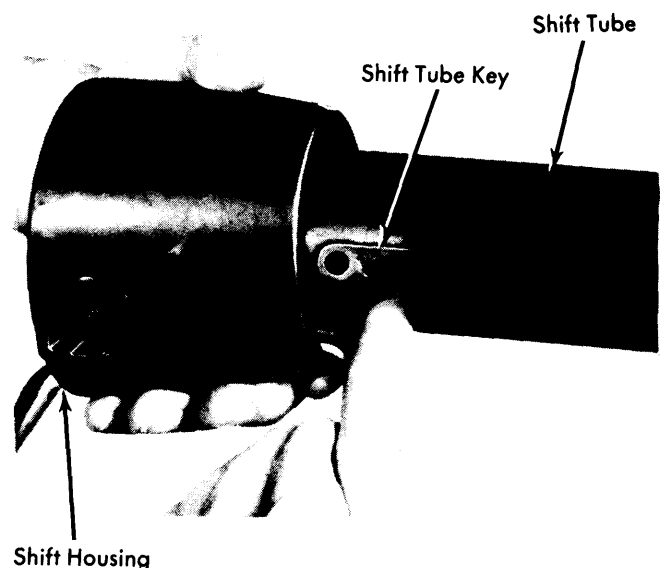

Fig. 10 Installing Shift Tube Into The Shift Housing

CHRYSLER CORP. (Cont.)

2) Install shift tube assembly into jacket but do not tighten bushing adjustment screws yet. Place lever spacer against 2nd-3rd lever on shift tube. Install 1st-Reverse lever on shift tube against lever spacer. Install lower support for shift tube and levers, then tighten screws. Place spring washer on shift housing using grease to hold it in place. Install shift housing over jacket while guiding shift tube key into slot in housing.

3) Insert shift lever into shift housing and drive in retaining roll pin while supporting housing with socket to protect paint. At lower end, adjust shift lever end play by rotating bushing screws in jacket slots so that end play is eliminated but levers move easily, then tighten screws. Proceed to step 7) to continue disassembly procedure.

4) On vehicles with automatic transmission, install "O" ring retainer, "O" ring, and floor plate on lower end of column jacket. Slide shift tube and support into column jacket. Align holes and install screws through jacket into support at lower end of jacket and tighten.

5) Place spring washer on shift housing so that center of curved washer bears against housing hub. Use grease to hold washer in position. Install shift housing over jacket while guiding shift tube key into housing. Hold parts firmly together and tighten lock screw in shift housing. Bend corners of slot in shift tube out against shift housing casting.

6) Seat lock housing on top of jacket, indexing key in housing with slot in jacket. Insert all four screws and tighten them alternately in steps to insure proper seating of housing on jacket. Inset shift lever and shift lever gate spring into shift housing and drive in retaining roll pin. Support housing with socket to protect paint.

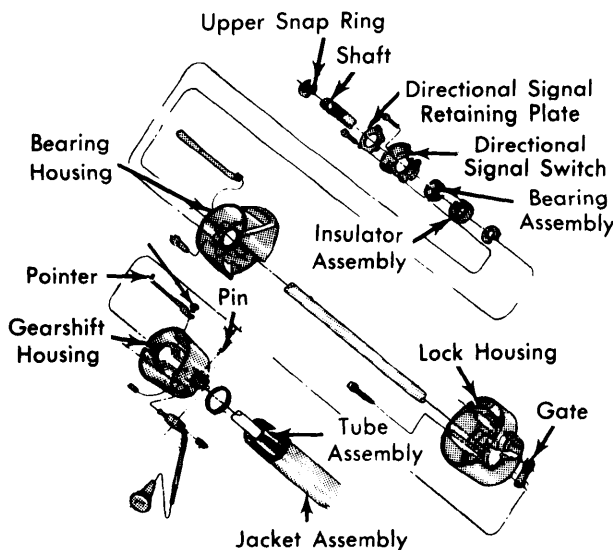

Fig. 11 Steering Column For Automatic Transmission On All Models Except "B", "PB" & "M"

7) Position ignition switch to center detent ("OFF") position. Feed wires down through space between housing and jacket. Position switch in housing and tighten three mounting screws. With lock cylinder in "LOCK" position and key removed, insert cylinder into lock housing.

8) Press cylinder into place until contact is made with pin on ignition switch cam. Insert key into lock and rotate lock until slot in cylinder plate lines up with pin. Press lock cylinder into lock housing, making sure retainer bar snaps into its slot in lock housing.

9) Insert steering shaft assembly into column and shift tube assembly. Install bearing lower snap ring on steering shaft. Place rubber insulator with ground strap over column upper bearing and install assembly into bearing housing bore. Use a soap solution or rubber lubricant to ease installation.

10) Install directional signal switch in bearing housing, feeding wires through opening in housing. Install retaining plate over switch and tighten screws. Install directional signal lever or directional speed control lever on directional signal switch. Position bearing housing assembly on column jacket assembly, feeding wires through space between lower housing and jacket.

11) When installing housing, the steering shaft must be drawn and not pushed through bearing by using bearing inner race as a reaction member. Install suitable shaft puller (C-3879) onto steering shaft. Pull shaft into position, remove puller, and install upper snap ring.

12) Install and tighten three bearing housing-to-lock housing screws. Carefully install lamp assembly in bearing housing on automatic transmission models. Install wiring trough in place over wires, being careful not to pinch wires between trough and jacket.

TIGHTENING SPECIFICATIONS

Application	Torque
"B" & "PB" Models	
Column-to-Instrument Panel	30 Ft. Lbs.
Floor Plate Retaining Bolts	200 INCH Lbs.
Steering Wheel Retaining Nut	24 Ft. Lbs.
Lower Shift Lever Support Bolts	30 INCH Lbs.
Lower Support Bolts	50 INCH Lbs.
Shift Lever Bushing Bolts	30 INCH Lbs.
Bearing Housing Retainer Bolts	50 INCH Lbs.
"M" Models	
Steering Wheel Retaining Nut	27 Ft. Lbs.
Turn Signal Retaining Screws	27 INCH Lbs.
Bearing Housing-to-Lock Housing	35 INCH Lbs.
"Pot" Type Coupling Nuts	45 Ft. Lbs.
Coupling-to-Steering Gear Worm Shaft	30 Ft. Lbs.
All Other Models	
Steering Gear-to-Steering Shaft	30 Ft. Lbs.
Steering Wheel Retaining Nut	27 Ft. Lbs.
Steering Column Bracket	110 INCH Lbs.
Lower Support Bolts	30 INCH Lbs.
Lock Housing-to-Jacket	80 INCH Lbs.
Shift Lever Bushing Bolts	30 INCH Lbs.
Turn Signal Switch Retaining Plate	27 INCH Lbs.
Upper Bearing Retainer Bolts	30 INCH Lbs.
Bearing Housing-to-Lock Housing	35 INCH Lbs.